

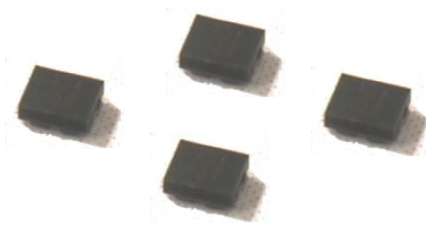

# Data Sheet of SAW Components



Note : Murata SAW Component is applicable for Cellular /Cordless phone (Terminal) relevant market only.  
Please also read caution at the end of this document.

# SAW FILTER FOR GSM1800/GSM1900

Murata part number :SAWFD1G84CB0F0A (fc=1842.5MHz)

## Package Dimensions

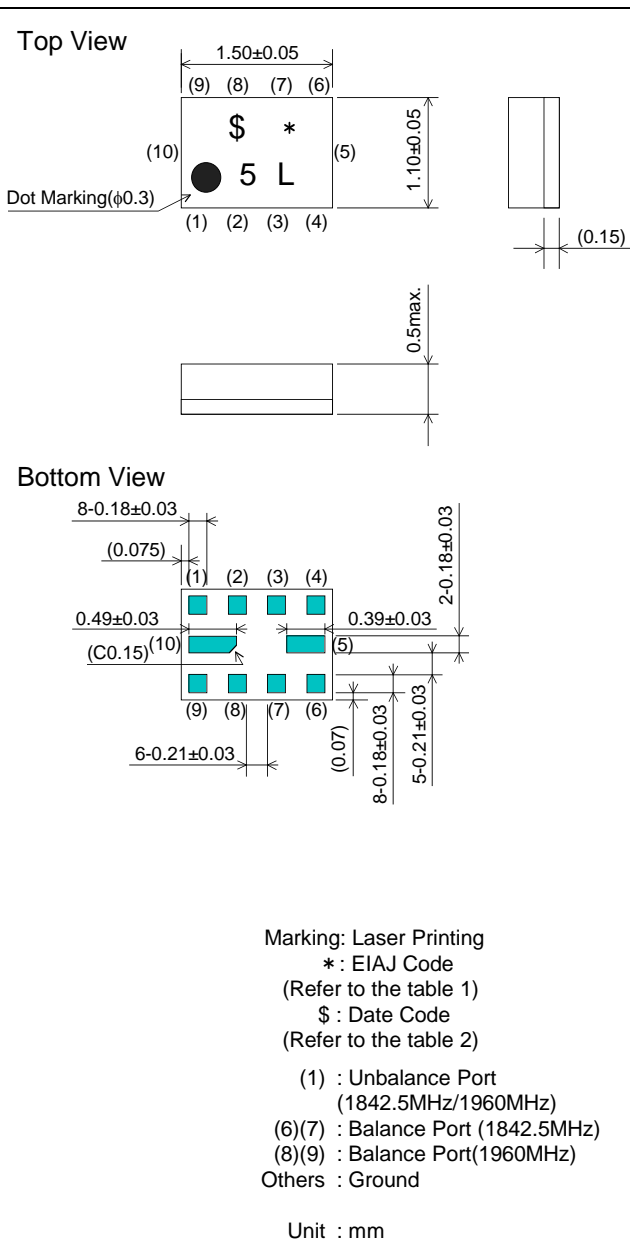

## Specification

Item	Specification		
	-30 to 85°C	25±2°C	typ.
Nominal Center Frequency(fc)	1842.5MHz		
Insertion Loss (1805 to 1880MHz)	2.6 dB max.	2.1 dB max.	1.7 dB
Absolute Attenuation			
1) 0.1 to 1300 MHz	35 dB min.	35 dB min.	40 dB
2) 1300 to 1705 MHz	20 dB min.	20 dB min.	27 dB
3) 1705 to 1785 MHz	10 dB min.	11 dB min.	13 dB
4) 1920 to 1980 MHz	17 dB min.	17 dB min.	19 dB
5) 1980 to 2030 MHz	18 dB min.	20 dB min.	23 dB
6) 2030 to 3000 MHz	23 dB min.	23 dB min.	27 dB
7) 3000 to 4000 MHz	36 dB min.	36 dB min.	40 dB
8) 4000 to 5000 MHz	33 dB min.	33 dB min.	37 dB
9) 5000 to 6000 MHz	27 dB min.	27 dB min.	31 dB
Ripple Deviation (1805 to 1880MHz)	1.6 dB max.	0.9 dB max.	0.5 dB
VSWR (1805 to 1880MHz)	2.3 max.	2.0 max.	1.6
Amplitude Balance (1805 to 1880MHz)	±1.2 dB max.	±1.0 dB max.	+0.7dB
Phase Balance (1805 to 1880MHz)	180±9deg. max.	180±8deg. max.	180.0+3.9deg.
Unbalance Port Matching Impedance (nominal)	50Ω//4.3nH		
Balance Port Matching Impedance (nominal)	150Ω//18nH		
Input Signal Level	20mW (+13dBm), 2000 hours		

# SAW FILTER FOR GSM1800/GSM1900

Murata part number :SAWFD1G84CB0F0A ( $f_c=1842.5\text{MHz}$ )

## Frequency Performance

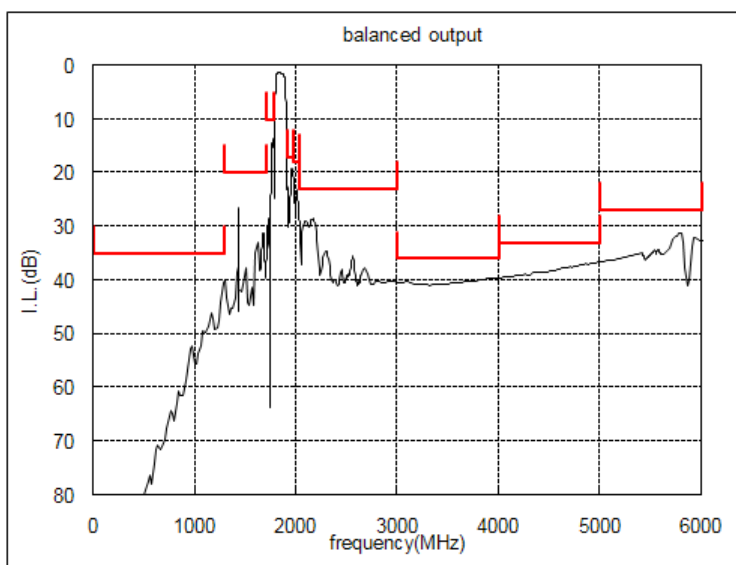
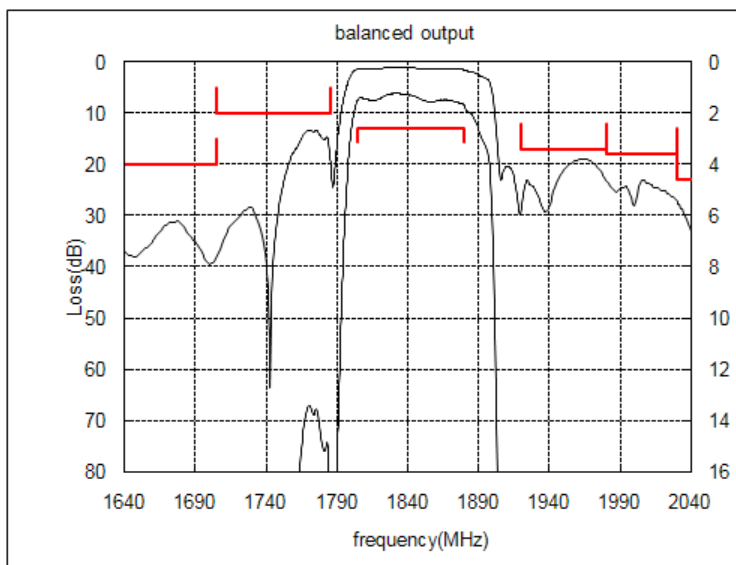

### Amplitude balance

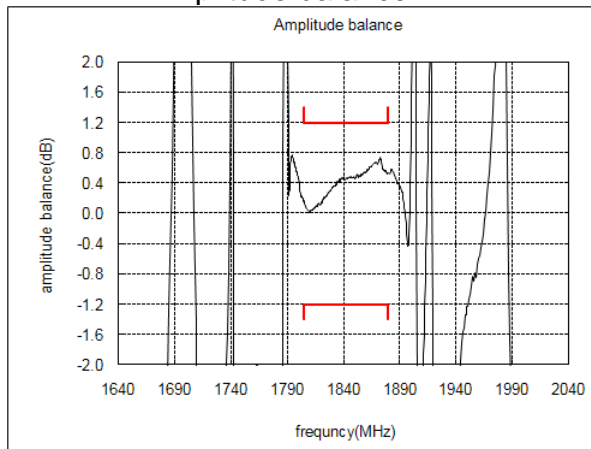

### Phase balance

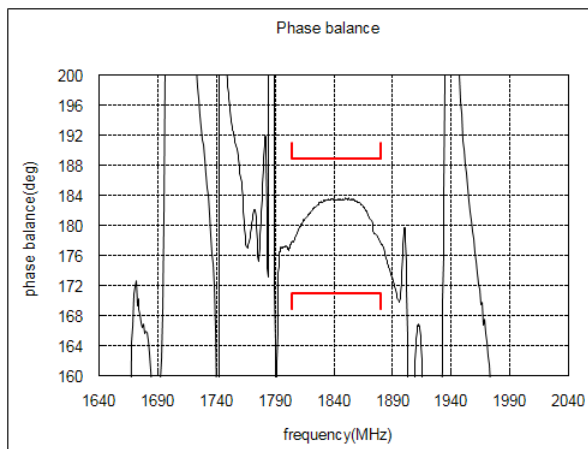

# SAW FILTER FOR GSM1800/GSM1900

Murata part number :SAWFD1G84CB0F0A (fc=1960MHz)

## Package Dimensions

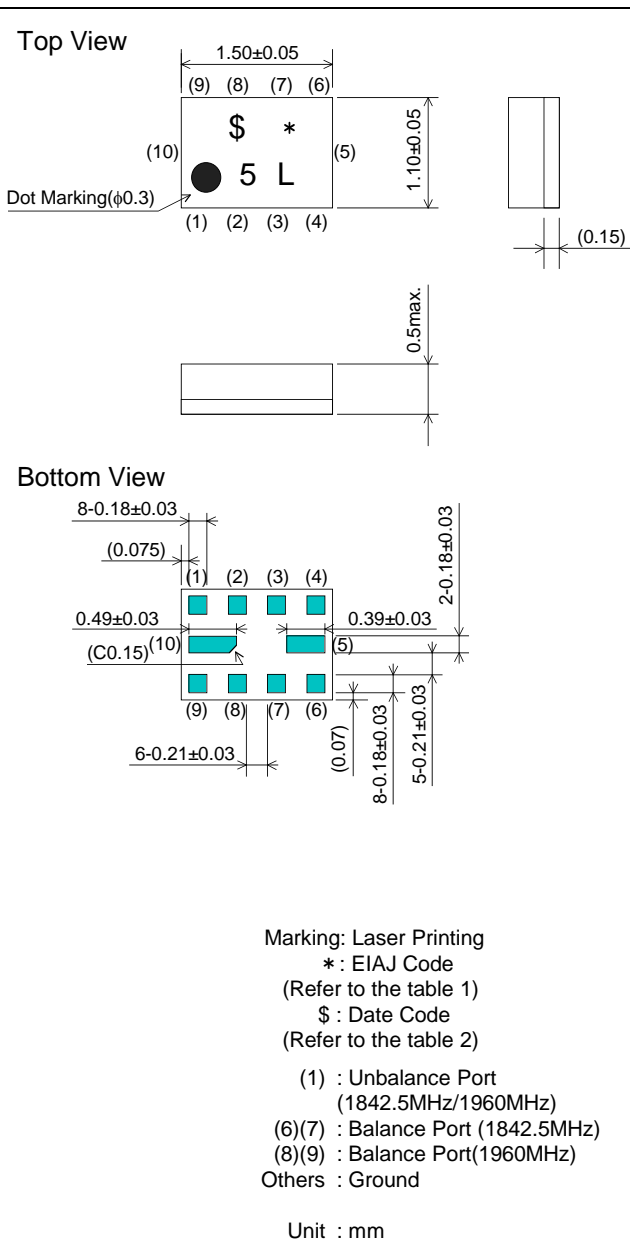

## Specification

Item	Specification		
	-30 to 85°C	25±2°C	typ.
Nominal Center Frequency(fc)	1960 MHz		
Insertion Loss (1930 to 1990MHz)	2.9 dB max.	2.3 dB max.	2.0 dB
Absolute Attenuation			
1) 0.1 to 1830 MHz	23 dB min.	23 dB min.	29 dB
2) 1830 to 1850 MHz	27 dB min.	27 dB min.	31 dB
3) 1850 to 1890 MHz	23 dB min.	25 dB min.	30 dB
4) 1890 to 1910 MHz	13 dB min.	13 dB min.	18 dB
5) 2010 to 2070 MHz	8 dB min.	16.5 dB min.	18.5 dB
6) 2070 to 2400 MHz	25 dB min.	30 dB min.	37 dB
7) 2400 to 3000 MHz	35 dB min.	35 dB min.	42 dB
8) 3000 to 5700 MHz	40 dB min.	40 dB min.	46 dB
9) 5700 to 5970 MHz	40 dB min.	40 dB min.	46 dB
10) 5970 to 6000 MHz	40 dB min.	40 dB min.	48 dB
Ripple Deviation (1930 to 1990MHz)	1.6 dB max.	0.9 dB max.	0.6 dB
VSWR (1930 to 1990MHz)	2.1 max.	1.8 max.	1.5
Amplitude Balance (1930 to 1990MHz)	±1.4 dB max.	±1.3 dB max.	+0.9dB
Phase Balance (1930 to 1990MHz)	180±8deg. max.	180±7deg. max.	180.0+3.6deg.
Unbalance Port Matching Impedance (nominal)	50Ω//4.3nH		
Balance Port Matching Impedance (nominal)	150Ω//18nH		
Input Signal Level	20mW (+13dBm), 2000 hours		

# SAW FILTER FOR GSM1800/GSM1900

Murata part number :SAWFD1G84CB0F0A (fc=1960MHz)

## Frequency Performance

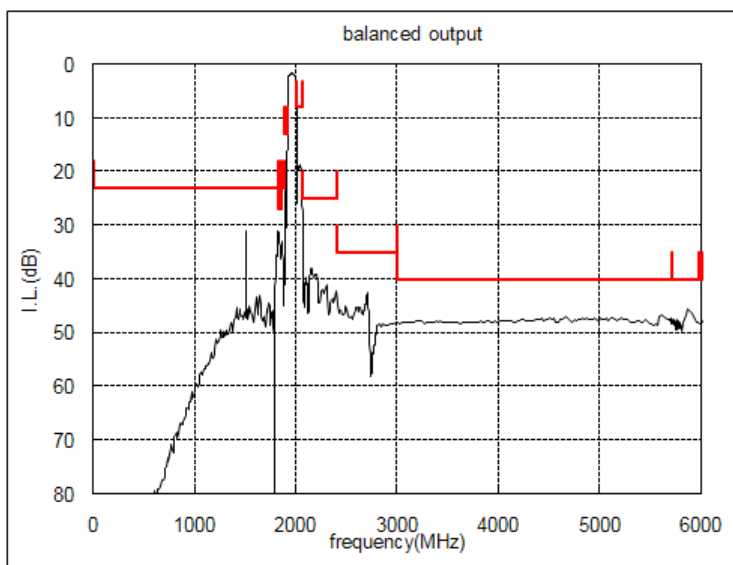
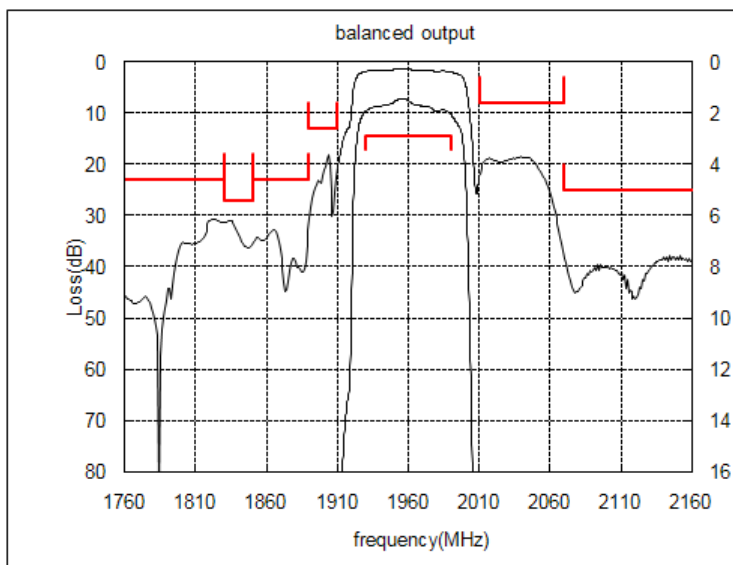

### Amplitude balance

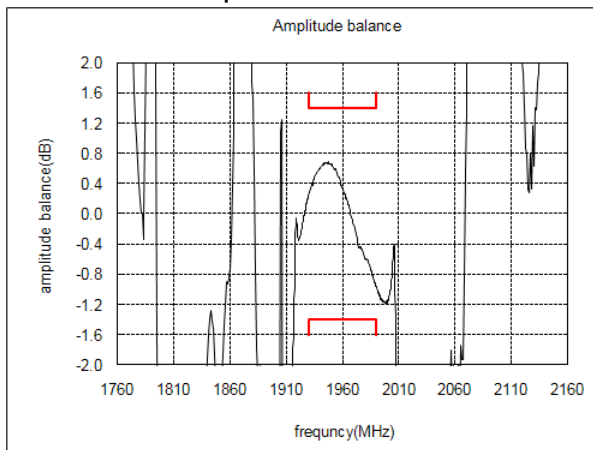

### Phase balance

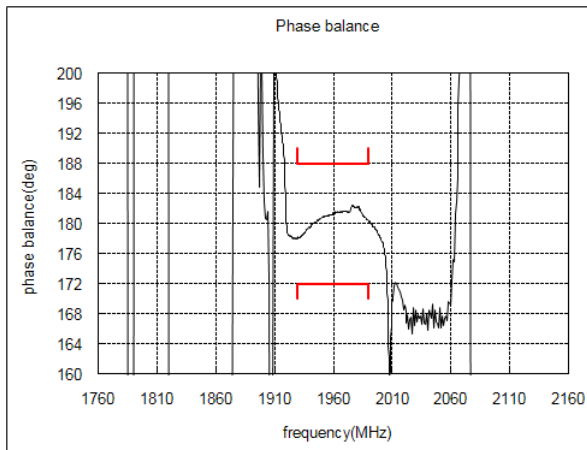

# SAW FILTER FOR GSM1800/GSM1900

Murata part number :SAWFD1G84CB0F0A

## Dimensions of Carrier Tape

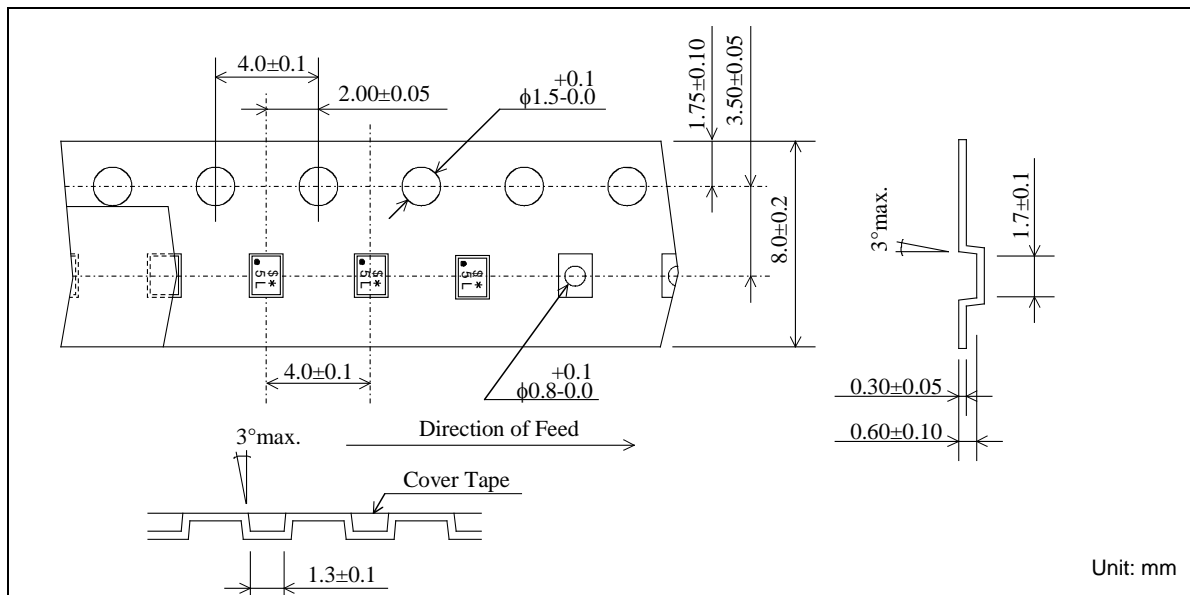

## Dimensions of Tape

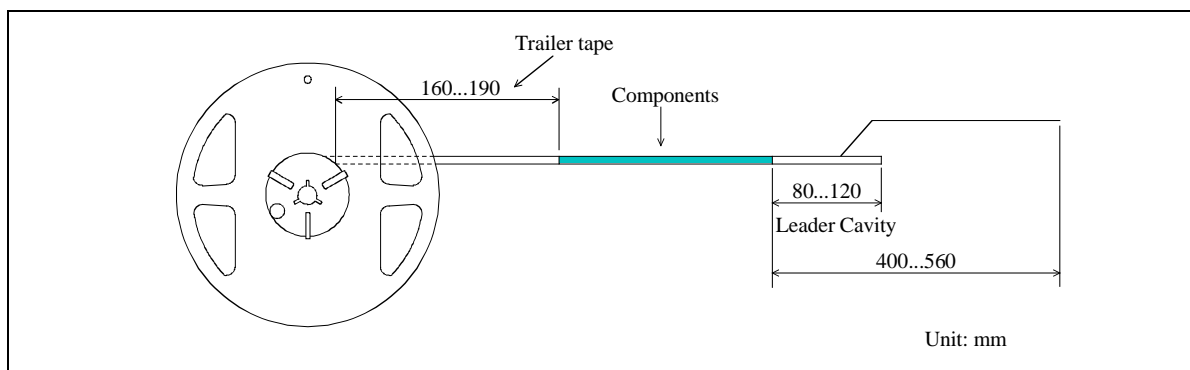

## Dimensions of Reel

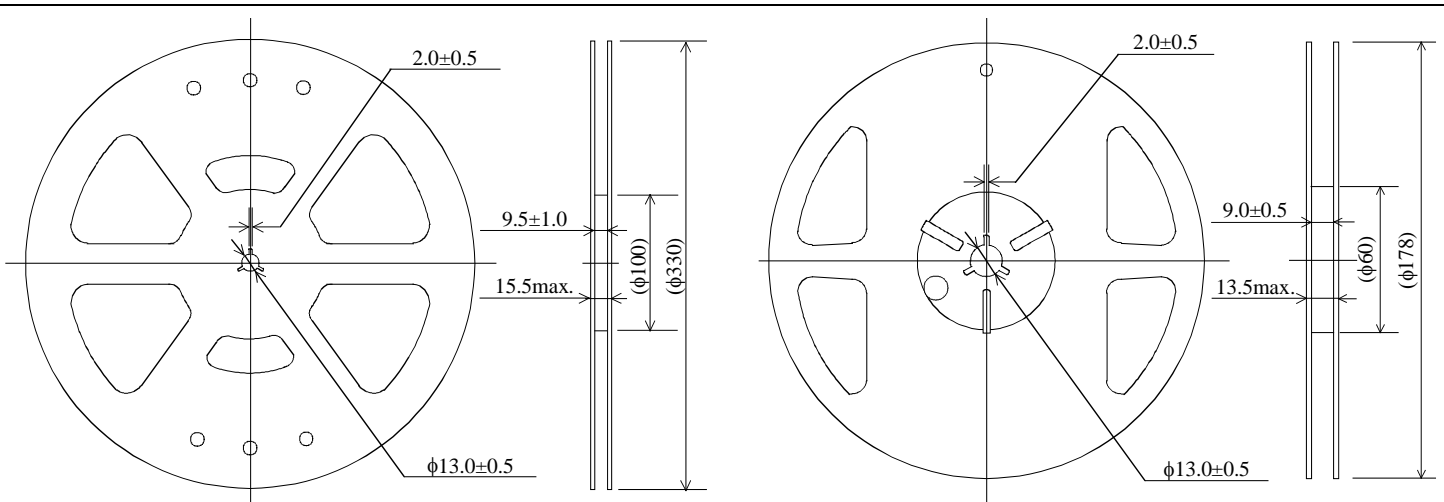

SAWFD1G84CB0F0AR00 ... 10000pcs/reel

SAWFD1G84CB0F0AR15 ... 5000pcs/reel

Unit: mm

# SAW FILTER FOR GSM1800/GSM1900

Murata part number :SAWFD1G84CB0F0A

## Recommended Land Pattern

Top View

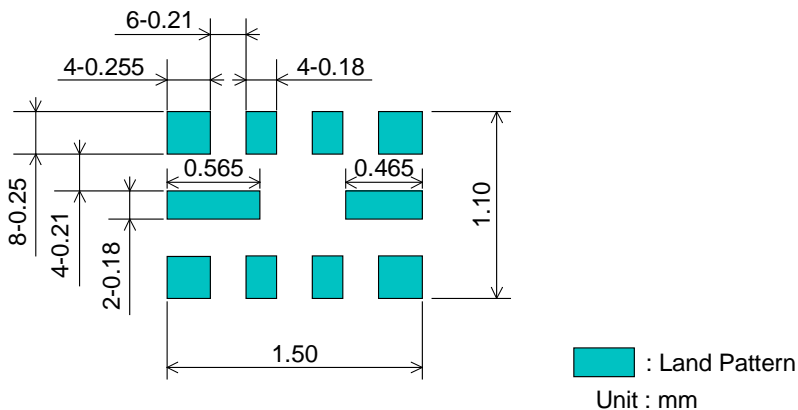

## Test Circuit

Bottom View

1842.5MHz

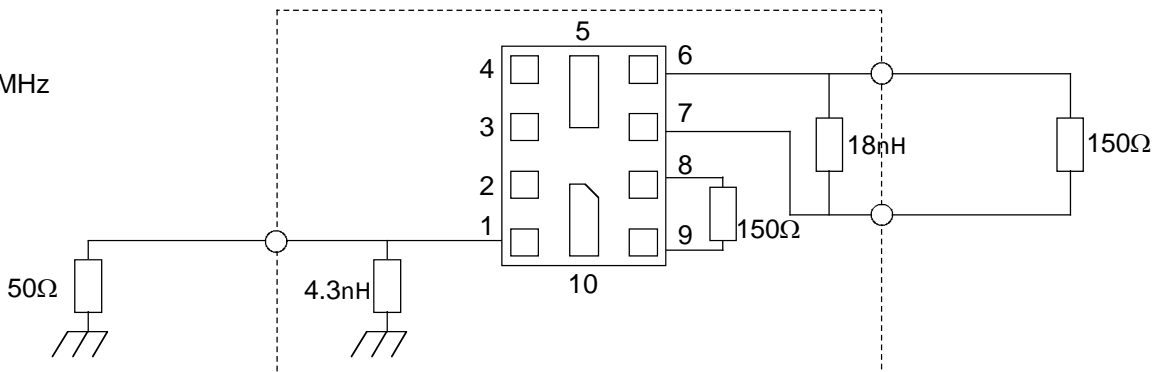

1960MHz

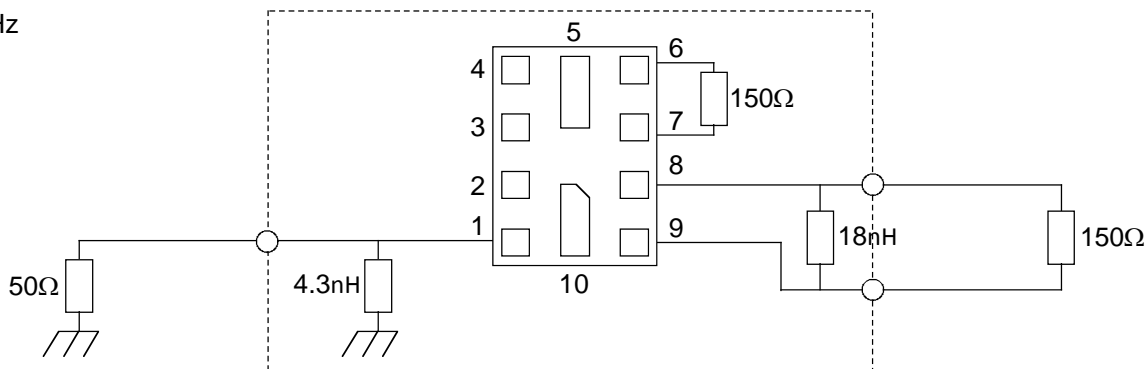

# SAW FILTER FOR GSM1800/GSM1900

Murata part number :SAWFD1G84CB0F0A

## ■ RoHS Compliance

This component is compliant with RoHS directive.

This component was always RoHS compliant from the first date of manufacture.

### • Caution - Limitation of Applications

This product is intended for the following applications only; however, please do not use this product in these applications where defects might directly cause damage to a third party's life, body or property.

- a. Mobile Telephone
- b. Cordless phone (except for Automotive use)
- c. PC (Including Notebook PC, Netbook PC, Tablet)
- d. Game
- e. Camera (except for Business/security use)
- f. Set Top Box
- g. Electronic dictionary
- h. Digital audio equipment

• This catalog is for reference only and not an official product specification document, therefore, please review and approve our official product specification before ordering this product.

## ■ Marking code

Table 1 \* : EIAJ Code

This rule of code is applied repeatedly every four year.

2009	Jan.	Feb.	Mar.	Apr.	May	Jun.	Jul.	Aug.	Sep.	Oct.	Nov.	Dec.
2013	A	B	C	D	E	F	G	H	J	K	L	M
2017												
2010	Jan.	Feb.	Mar.	Apr.	May	Jun.	Jul.	Aug.	Sep.	Oct.	Nov.	Dec.
2014	N	P	Q	R	S	T	U	V	W	X	Y	Z
2018												
2011	Jan.	Feb.	Mar.	Apr.	May	Jun.	Jul.	Aug.	Sep.	Oct.	Nov.	Dec.
2015	a	b	c̄	d	e	f	g	h	j	k	l	m
2019												
2012	Jan.	Feb.	Mar.	Apr.	May	Jun.	Jul.	Aug.	Sep.	Oct.	Nov.	Dec.
2016	n	p	q	r	s	t	u	v	w	x	y	z
2020												

Table 2 \$: Date Code

date	1st	2nd	3rd	4th	5th	6th	7th	8th	9th	10th	
code	A	B	C	D	E	F	G	H	J	K	
date	11th	12th	13th	14th	15th	16th	17th	18th	19th	20th	
code	L	M	N	P	Q	R	S	T	U	V	
date	21st	22nd	23rd	24th	25th	26th	27th	28th	29th	30th	31st
code	W	X	Y	Z	a	b	c̄	d	e	f	g