

1. Automatic Measurement Probe (MM126036)

- Automatic measurement probe (MM126036) should be used on the condition in Fig. 1 for good connection without any damages.
- The engagement strokes from the flange to the tip of probe is 18.28mm to 19.78mm with vertical (0 ± 2 degree) direction.

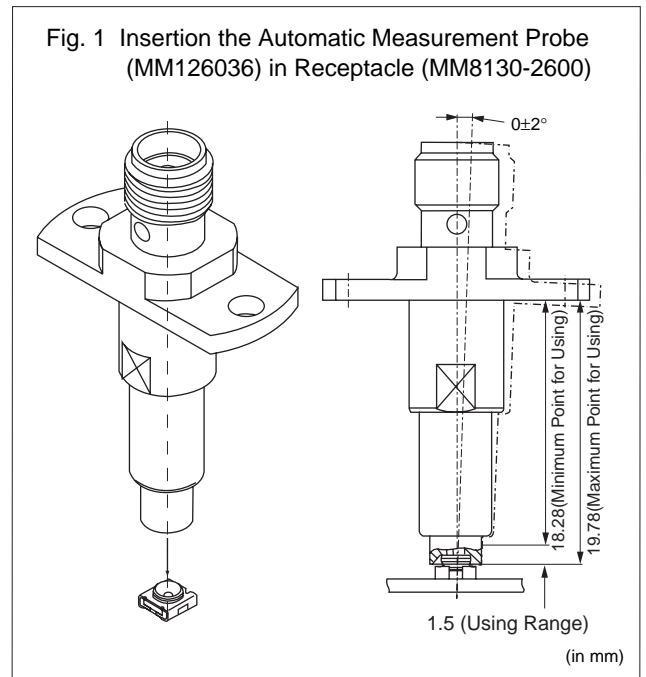

2. L Type Probe with Locking Function (MXHS83QE3000, MXHS83QH3000)

- Do not try to pull the cable, when a connector with a coaxial cable is handled.
- Do not give a twisted torque to the cable and connector.
- Mechanical stress:
The stress to the connector should be limited as figure shown right.

- (1) Stress to the housing.
Stress A and B: 0.5N max.
- (2) Stress to the outer sleeve.
Stress C: 0.6N max.
Stress D: 0.6N max.
- (3) Cable pull strength.
Stress E: 0.5N max.

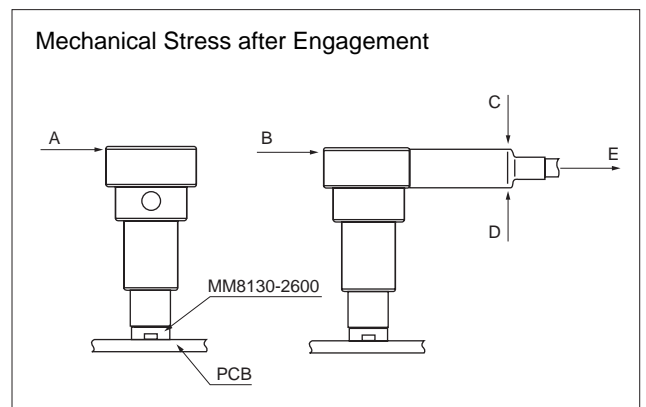

3. Usage Condition

- (1) Do not apply electrical voltage greater than specified in the catalog. It might cause degradation or destruction of the product. Even if it endures during a short time, long time qualification is not guaranteed.
- (2) Confirm that product performance is not influenced with any other components or materials which directly contact products.

4. Handling

Do not apply excessive shock or load to subassembly products such as soldered printed circuit board in case handling or transporting.