

© FREESCALE SEMICONDUCTOR, INC. ALL RIGHTS RESERVED.	MECHANICAL OUTLINE	PRINT VERSION NOT TO SCALE	
TITLE: TO-270 WIDE BODY 16 LEAD, GULL WING	DOCUMENT NO: 98ASA10755D	REV: A	
	CASE NUMBER: 1887-01	31 AUG 2007	
	STANDARD: NON-JEDEC		

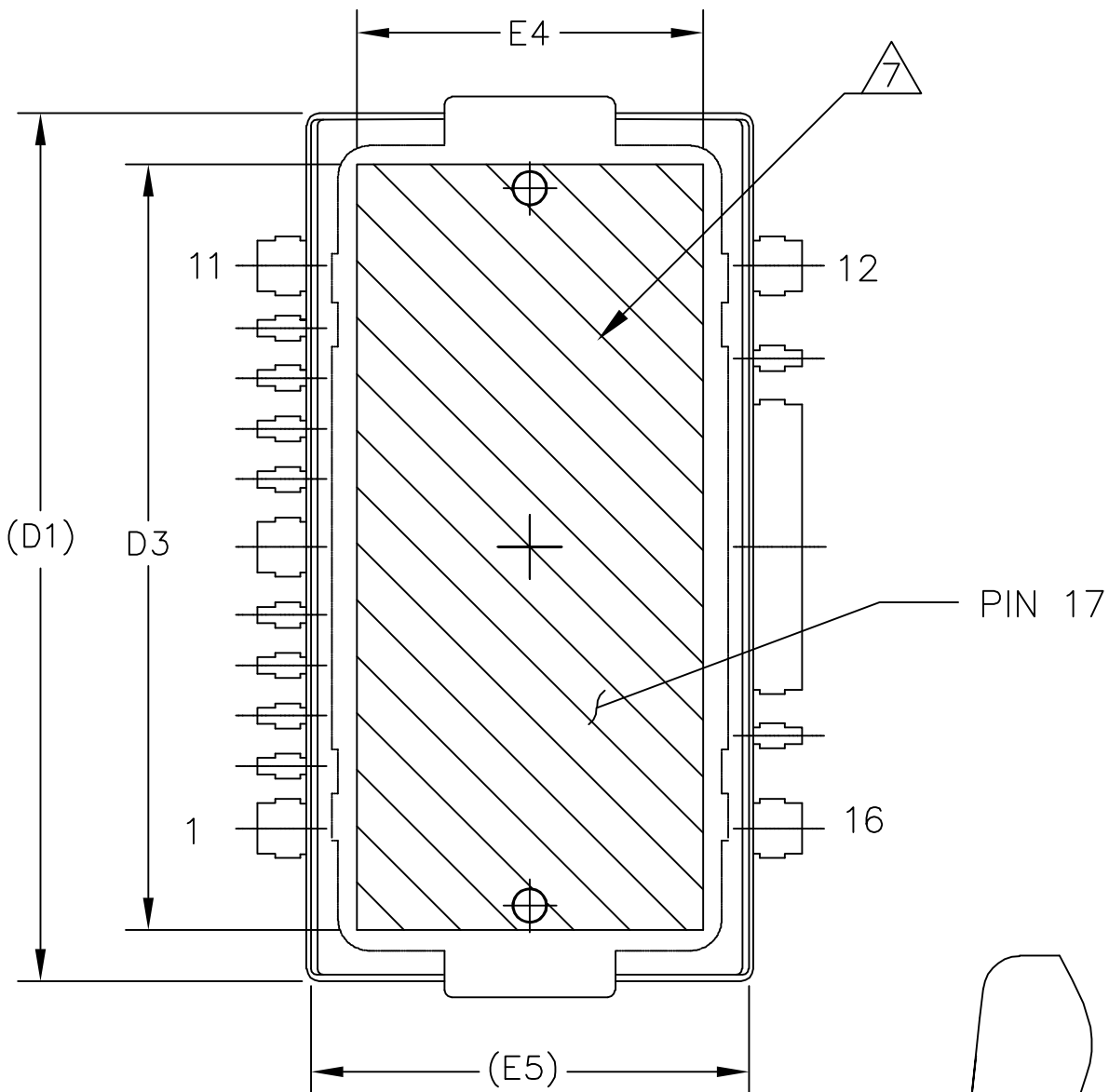

VIEW Y-Y

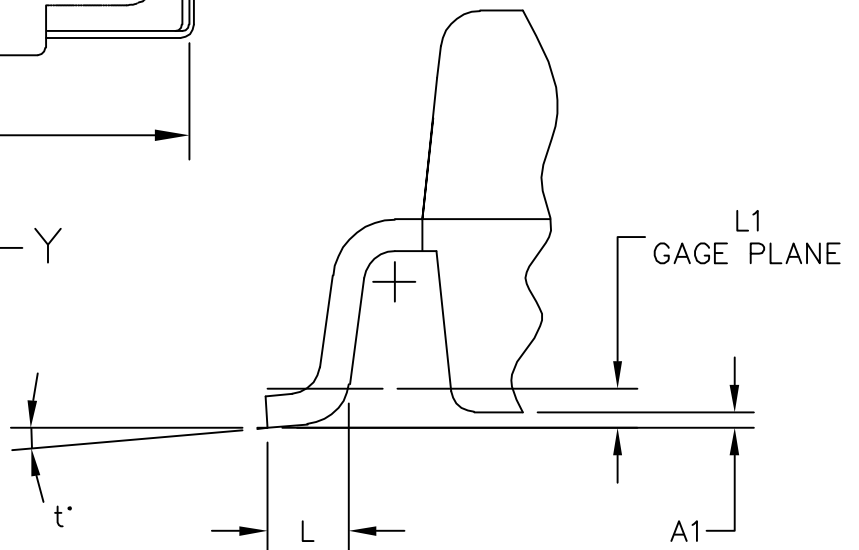

DETAIL "Y"

© FREESCALE SEMICONDUCTOR, INC. ALL RIGHTS RESERVED.	MECHANICAL OUTLINE	PRINT VERSION NOT TO SCALE	
TITLE: TO-270 WIDE BODY 16 LEAD, GULL WING	DOCUMENT NO: 98ASA10755D	REV: A	
	CASE NUMBER: 1887-01	31 AUG 2007	
	STANDARD: NON-JEDEC		

NOTES:

1. CONTROLLING DIMENSION: INCH
2. INTERPRET DIMENSIONS AND TOLERANCES PER ASME Y14.5M-1994.
3. DATUM PLANE -H- IS LOCATED AT THE TOP OF LEAD AND IS COINCIDENT WITH THE LEAD WHERE THE LEAD EXITS THE PLASTIC BODY AT THE TOP OF THE PARTING LINE.
4. DIMENSIONS "D" AND "E1" DO NOT INCLUDE MOLD PROTRUSION. ALLOWABLE PROTRUSION IS .006 (0.15) PER SIDE. DIMENSIONS "D" AND "E1" DO INCLUDE MOLD MISMATCH AND ARE DETERMINED AT DATUM PLANE -H-.
5. DIMENSIONS "b", "b1", "b2" AND "b3" DO NOT INCLUDE DAMBAR PROTRUSION. ALLOWABLE DAMBAR PROTRUSION SHALL BE .005 (0.13) TOTAL IN EXCESS OF THE "b", "b1", "b2" AND "b3" DIMENSIONS AT MAXIMUM MATERIAL CONDITION.
6. DATUM -A- AND -B- TO BE DETERMINED AT DATUM PLANE -H-.
7. HATCHING REPRESENTS EXPOSED AREA OF THE HEAT SLUG. HATCHED AREA SHOWN IS ON THE SAME PLANE.

DIM	INCH		MILLIMETER		DIM	INCH		MILLIMETER	
	MIN	MAX	MIN	MAX		MIN	MAX	MIN	MAX
A	.100	.104	2.54	2.64	L	.018	.024	0.46	0.61
A1	.001	.004	0.02	0.10	L1	.010 BSC		0.25 BSC	
A2	.099	.110	2.51	2.79	b	.011	.017	0.28	0.43
D	.712	.720	18.08	18.29	b1	.037	.043	0.94	1.09
D1	.688	.692	17.48	17.58	b2	.037	.043	0.94	1.09
D2	.011	.019	0.28	0.48	b3	.225	.231	5.72	5.87
D3	.600	---	15.24	---	c1	.007	.011	0.18	0.28
E	.429	.437	10.9	11.1	e	.054 BSC		1.37 BSC	
E1	.353	.357	8.97	9.07	e1	.040 BSC		1.02 BSC	
E2	.132	.140	3.35	3.56	e2	.224 BSC		5.69 BSC	
E3	.124	.132	3.15	3.35	e3	.150 BSC		3.81 BSC	
E4	.270	---	6.86	---	t	2'	8'	2'	8'
E5	.346	.350	8.79	8.89	aaa	.004		0.10	

© FREESCALE SEMICONDUCTOR, INC.
ALL RIGHTS RESERVED.

MECHANICAL OUTLINE

PRINT VERSION NOT TO SCALE

TITLE: TO-270 WIDE BODY
16 LEAD,
GULL WING

DOCUMENT NO: 98ASA10755D

REV: A

CASE NUMBER: 1887-01

31 AUG 2007

STANDARD: NON-JEDEC