



Package Style: MCM 16-Pin, 8.0mm x 8.0mm



### Features

- Frequency Range 1850MHz to 2050MHz
- Internally Matched to 50Ω on All RF Ports
- Analog Voltage Variable Attenuator with 3.3V Control Range
- Bypass Mode of LNA for High Dynamic Range
- Max Gain = 35dB min.
- Noise Figure of 0.65dB Typical
- Gain Control Range = 35dB
- High IIP3 = 2dBm
- Single +5V Supply
- Small 16-Pin, 8.0mm x 8.0mm, Multi-Chip Module (MCM)

### Applications

- Cellular Base station, Remote Radio Heads
- Active Antenna Radios
- 3G, LTE Infrastructure
- Low Noise, Variable Gain with High Linearity

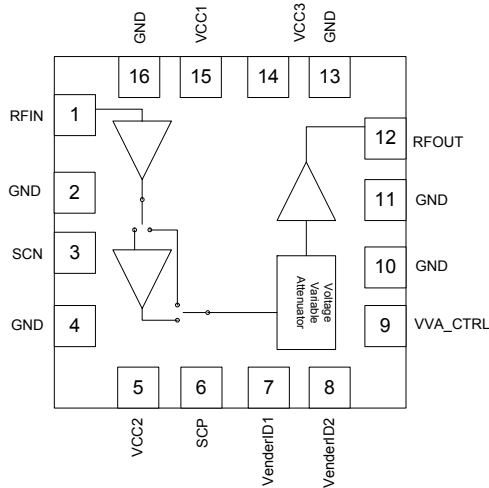

Functional Block Diagram

### Product Description

RFMD's RFLA1018 is an analog-controlled voltage-variable gain amplifier featuring high linearity and very low noise figure. This LNA with bypass mode and variable attenuator provides a minimum 35dB of dynamic gain range. The RFLA1018 has a 3.3V control range with maximum gain at 0V. The LNA is temperature compensated to reduce gain variation. A noise figure of 0.65dB and an IIP3 of 2dBm make this component ideal for receiver input lineups. The RFLA1018 is packaged in a small 8.0mm x 8.0mm leadless laminate MCM. This module is internally matched to 50Ω on all RF ports, making it easy to use with no external matching components required.

### Ordering Information

RFLA1018SR	7" Reel with 100 pieces
RFLA1018SQ	Sample Bag with 25 pieces
RFLA1018TR7	7" Reel with 750 pieces
RFLA1018TTR13	13" Reel with 2500 pieces
RFLA1018PCK-410	1850MHz to 2050MHz PCBA with 5-piece sample bag

### Optimum Technology Matching® Applied

- |   |                                      |  |                                    |
|---|--------------------------------------|--|------------------------------------|
| <input type="checkbox"/> GaAs HBT             | <input type="checkbox"/> SiGe BiCMOS | <input checked="" type="checkbox"/> GaAs pHEMT | <input type="checkbox"/> GaN HEMT  |
| <input type="checkbox"/> GaAs MESFET          | <input type="checkbox"/> Si BiCMOS   | <input type="checkbox"/> Si CMOS               | <input type="checkbox"/> BIFET HBT |
| <input checked="" type="checkbox"/> InGaP HBT | <input type="checkbox"/> SiGe HBT    | <input type="checkbox"/> Si BJT                | <input type="checkbox"/> SOI       |

## Absolute Maximum Ratings

Parameter	Rating	Unit
Supply Voltage	+5.5	V <sub>DC</sub>
Control Voltage	+5.5	V <sub>DC</sub>
DC Supply Current	400	mA
Power Dissipation	2000	mW
Max RF Input Power	27	dBm
Operating Temperature (T <sub>CASE</sub> )	-40 to +85	°C
Storage Temperature	-40 to +150	°C
Max Junction Temperature (T <sub>J</sub> )	160	°C
ESD Rating (HBM)	1000 (Class 1C)	V
Moisture Sensitivity Level	MSL3	



### Caution! ESD sensitive device.

Exceeding any one or a combination of the Absolute Maximum Rating conditions may cause permanent damage to the device. Extended application of Absolute Maximum Rating conditions to the device may reduce device reliability. Specified typical performance or functional operation of the device under Absolute Maximum Rating conditions is not implied.

The information in this publication is believed to be accurate and reliable. However, no responsibility is assumed by RF Micro Devices, Inc. ("RFMD") for its use, nor for any infringement of patents, or other rights of third parties, resulting from its use. No license is granted by implication or otherwise under any patent or patent rights of RFMD. RFMD reserves the right to change component circuitry, recommended application circuitry and specifications at any time without prior notice.



RFMD Green: RoHS compliant per EU Directive 2002/95/EC, halogen free per IEC 61249-2-21, < 1000 ppm each of antimony trioxide in polymeric materials and red phosphorus as a flame retardant, and <2% antimony in solder.

Parameter	Specification			Unit	Condition
	Min.	Typ.	Max.		
<b>High Gain Mode Data: 1920MHz to 1980MHz</b>					Temp = 25 °C, V <sub>CC</sub> = 5V, Standard Application Circuit
Frequency Range	1920		1980	MHz	
Max Gain	36	38		dB	Attenuation = Min, VVA_CV = 0V
Gain Flatness		0.75	1.1	dB	
Min. Gain		12	18.7	dB	
OIP3		38		dBm	Max Gain, Attenuation = Min, VVA_CV = 0V
IIP3		3		dBm	32dB to 35dB Gain
IIP3		6		dBm	30dB to 31dB Gain
IIP3		8		dBm	25dB to 29dB Gain
IIP3		9.5		dBm	18dB to 24dB Gain
OP1dB (Max Gain)		25.5		dBm	Attenuation = Min, VVA_CV = 0V
IP1dB		-9.5		dBm	30dB to 35dB Gain
IP1dB		-1.5		dBm	18dB to 24dB Gain
NF		0.65		dB	Max Gain, Attenuation = Min, VVA_CV = 0V
Input Return Loss		-25		dB	
Output Return Loss		-18		dB	
<b>Low Gain Mode Data: 1920MHz to 1980MHz</b>					Temp = 25 °C, V <sub>CC</sub> = 5V, Standard Application Circuit
Frequency Range	1920		1980	MHz	
Max Gain	20.3	22			Attenuation = Min, VVA_CV = 0V
Gain Flatness		0.25	1.1		
Min. Gain		-4	3	dB	
OIP3		36		dBm	(Max Gain)Attenuation = Min, VVA_CV = 0V
IIP3		19		dBm	16dB to 17dB Gain
IIP3		20.5		dBm	12dB to 15dB Gain
IIP3		19		dBm	5dB to 11dB Gain
IIP3		21		dBm	1dB to 4dB Gain

Parameter	Specification			Unit	Condition
	Min.	Typ.	Max.		
<b>Low Gain Mode Data: 1920MHz to 1980MHz (continued)</b>					Temp = 25 °C, V <sub>CC</sub> = 5V, Standard Application Circuit
OP1dB		25.5		dBm	Max Gain, Attenuation = Min, VVA_CV = 0V
IP1dB		8.5		dBm	16dB to 17dB Gain
IP1dB		9.5		dBm	15dB Gain
IP1dB		11		dBm	12dB to 14dB Gain
IP1dB		11		dBm	5dB to 11dB Gain
IP1dB		11		dBm	1dB to 4dB Gain
NF		1.5		dB	Max Gain, Attenuation = Min, VVA_CV = 0V
Input Return Loss		-27		dB	
Output Return Loss		-19		dB	
<b>High Gain Mode Data: 1850MHz to 2050MHz</b>					Temp = 25 °C, V <sub>CC</sub> = 5V, Standard Application Circuit
Frequency Range	1850		2050		
Max Gain		38			Attenuation = Min, VVA_CV = 0V
Gain Range HG	11.7		38		
OIP3		38			Max Gain, Attenuation = Min, VVA_CV = 0V
IIP3		2.9			32dB to 35dB Gain
IIP3		6.0			30dB to 31dB Gain
IIP3		9			25dB to 29dB Gain
IIP3		10			18dB to 24dB Gain
OP1dB		25			Max Gain, Attenuation = Min, VVA_CV = 0V
IP1dB		-10.5			30dB to 35dB Gain
IP1dB		-1			18dB to 24dB Gain
NF		0.6			Max Gain, Attenuation = Min, VVA_CV = 0V
Input Return Loss		-18			
Output Return Loss		-8			
<b>Low Gain Mode Data: 1850MHz to 2050MHz</b>					Temp = 25 °C, V <sub>CC</sub> = 5V, Standard Application Circuit
Frequency Range	1850		2050	MHz	
Max Gain LG		22			Attenuation = Min, VVA_CV = 0V
Gain Range LG	-2		22		
OIP3		36		dB	Max Gain, Attenuation = Min, VVA_CV = 0V
IIP3		19		dBm	16dB to 17dB Gain
IIP3		21		dBm	12dB to 15dB Gain
IIP3		19		dBm	5dB to 11dB Gain
IIP3		20		dBm	1dB to 4dB Gain
OP1dB		25		dBm	Max Gain, Attenuation = Min, VVA_CV = 0V
IP1dB		8		dBm	16dB to 17dB Gain
IP1dB		9		dBm	15dB Gain
IP1dB		10		dBm	12dB to 14dB Gain
IP1dB		10.5		dBm	5dB to 11dB Gain
IP1dB		11		dBm	1dB to 4dB Gain
NF		1.5		dB	Max Gain, Attenuation = Min, VVA_CV = 0V
Input Return Loss		-20		dB	
Output Return Loss		-17		dB	

Parameter	Specification			Unit	Condition
	Min.	Typ.	Max.		
<b>Power Supply</b>					Temp = 25 °C, V <sub>CC</sub> = 5V, Standard Application Circuit
Supply Voltage	4.75	5	5.25	V	
Gain Control Voltage	0		3.3	V	
Logic High	2		5	V	
Logic Low	0		1	V	
Thermal Resistance (R <sub>TH</sub> )		41.8			85 °C at 5.25V
<b>Current</b>					Temp = 25 °C, V <sub>CC</sub> = 5V, Standard Application Circuit
Current	250	290	320	mA	HG Mode
Current <sup>1</sup>	250	290	320	mA	LG Mode1
Current <sup>2</sup>	175	200	225	mA	LG Mode2

**Notes:**

1. LG mode with 2nd LNA bypass VCC2 still applied
2. LG mode with 2nd LNA bypass VCC2 disabled

## Typical Performance

**Gain versus Temperature**  
(High Gain Mode)

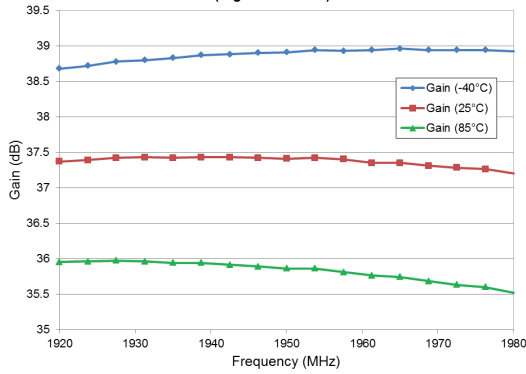

**Gain versus Temperature**  
(Low Gain Mode)

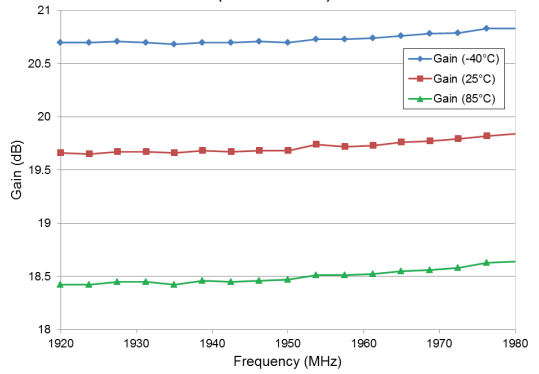

**Gain Flatness versus Voltage**  
**Control Voltage versus Temperature**  
(High Gain Mode)

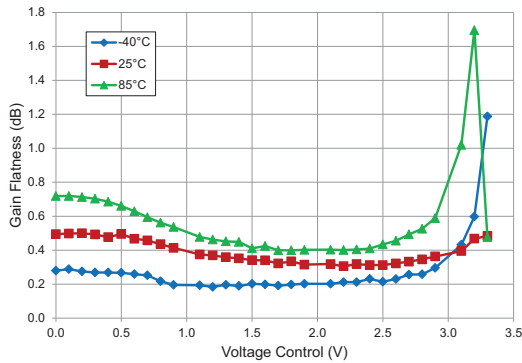

**Gain Flatness versus Voltage**  
**Control Voltage versus Temperature**  
(Low Gain Mode)

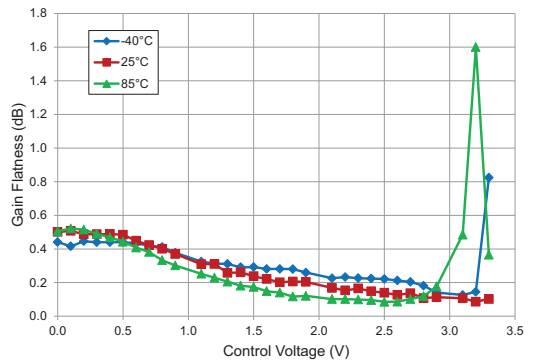

## Typical Performance

**Input Return Loss versus Temperature**  
(High Gain Mode)

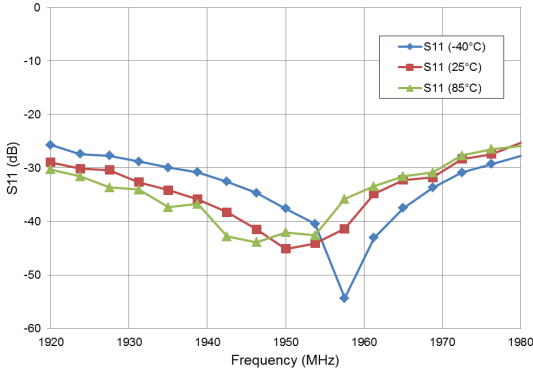

**Input Return Loss versus Temperature**  
(Low Gain Mode)

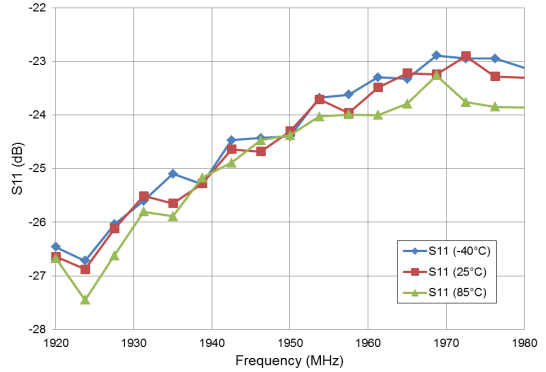

**Output Return Loss versus Temperature**  
(High Gain Mode)

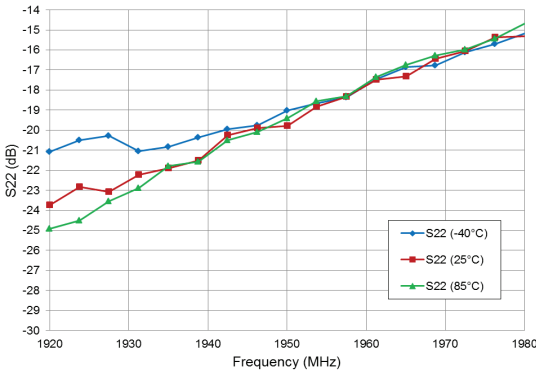

**Output Return Loss versus Temperature**  
(Low Gain Mode)

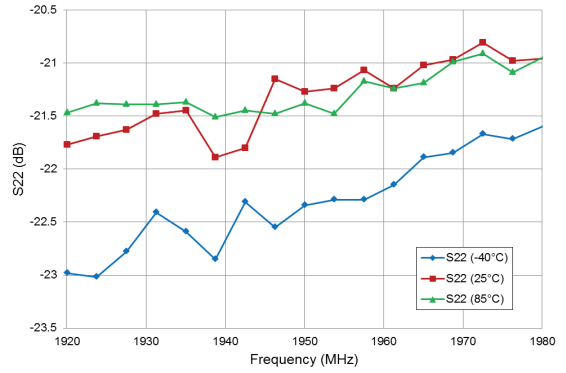

**IIP3 versus Gain versus Temperature at 1950MHz**  
(High Gain Mode)

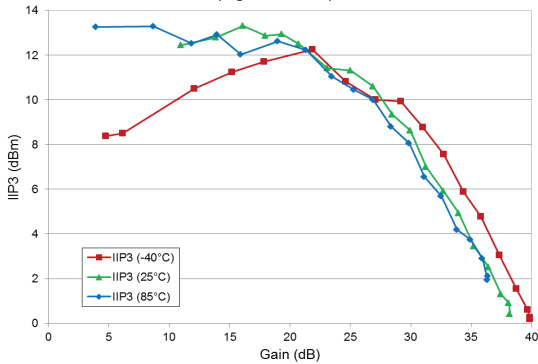

**IIP3 versus Gain versus Temperature at 1950MHz**  
(Low Gain Mode)

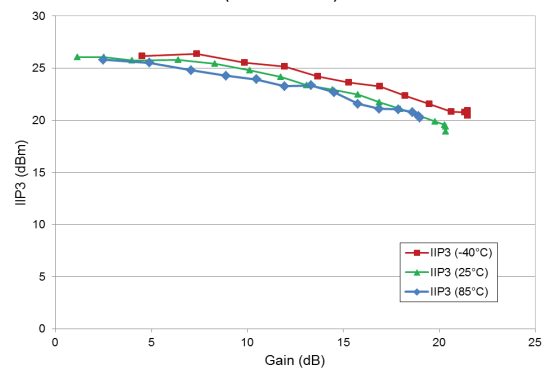

## Typical Performance

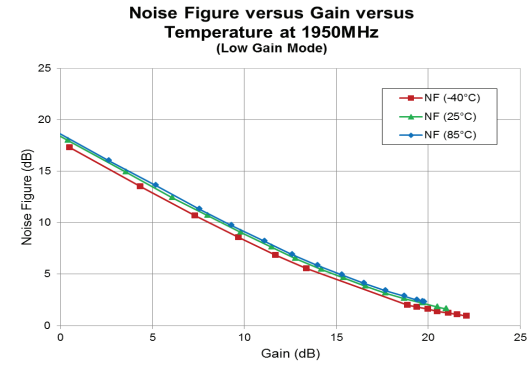
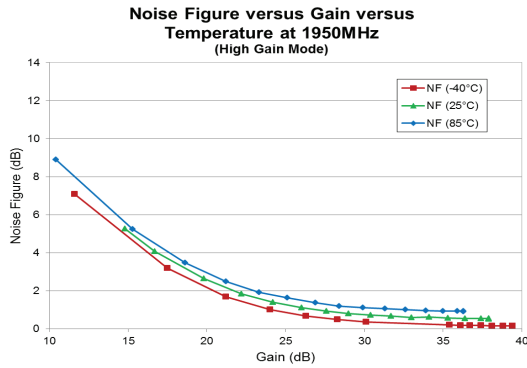
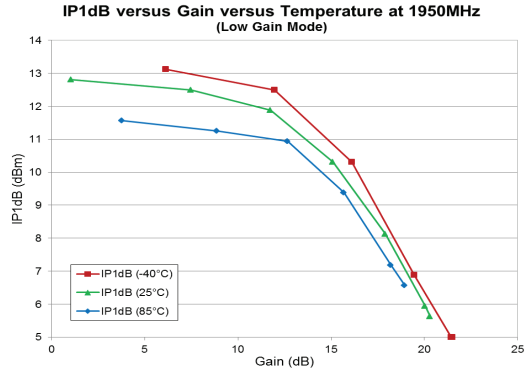
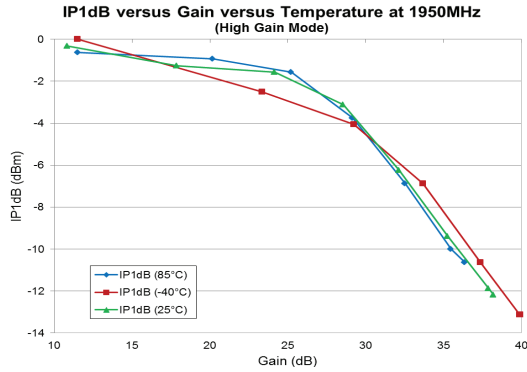

## Wide Band Plots

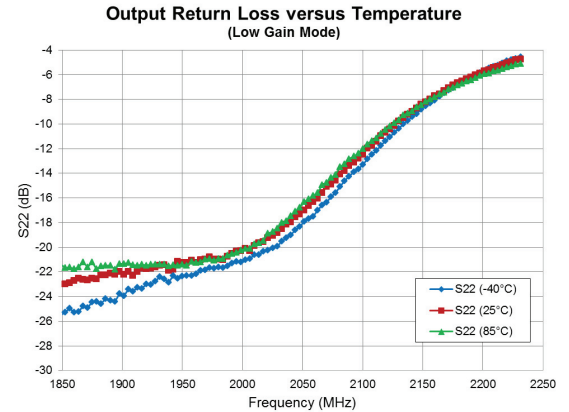
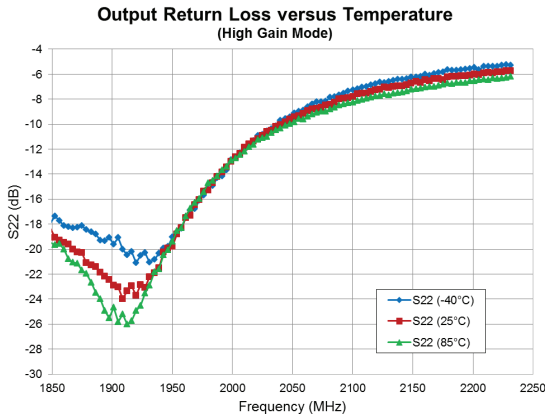
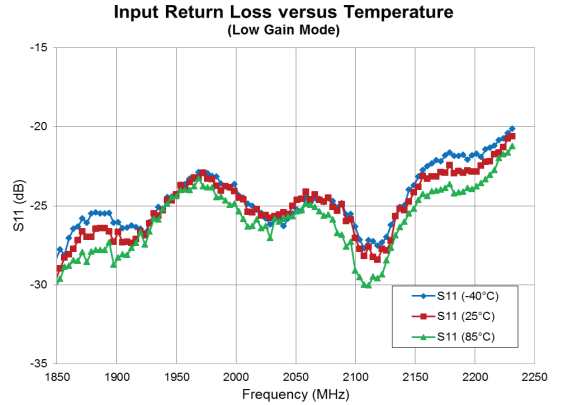
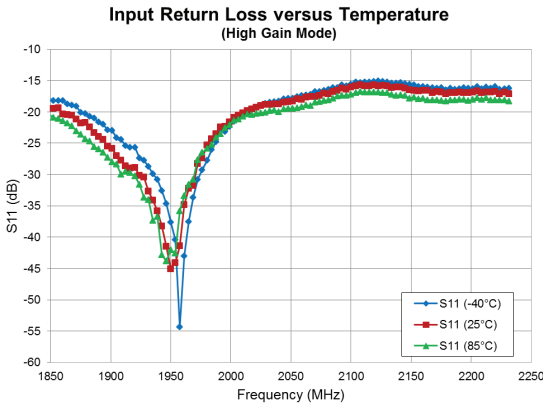
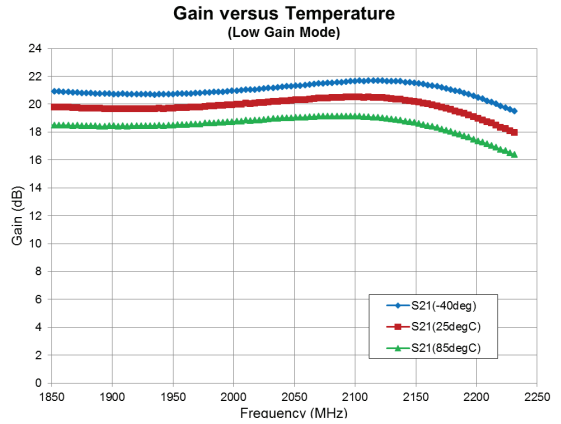
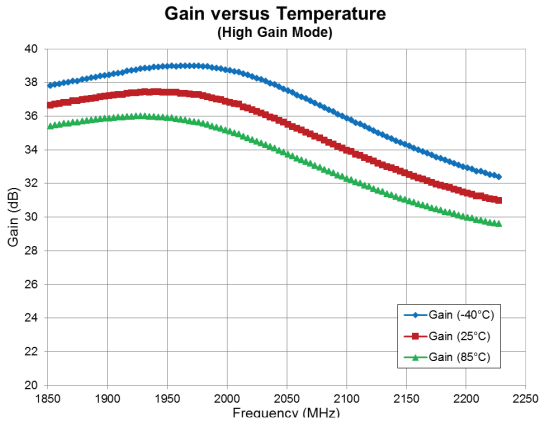

## Evaluation Board Schematic 1920MHz to 1980MHz Application Circuit

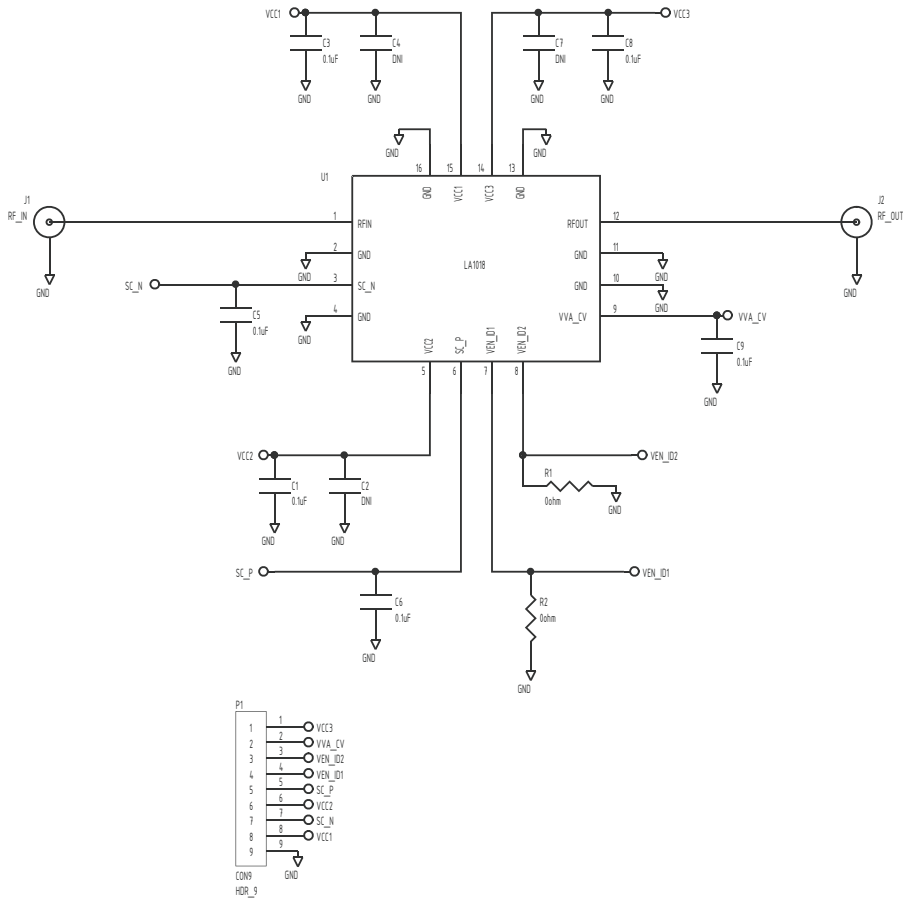

### Evaluation Board Build of Materials (BOM)

Description	Reference Designator	Manufacturer	Manufacturer's P/N
Evaluation Board		DDI	LA1018410(E)
CAP, 0.1µF, 10%, 16V, X7R, 0402	C1 ,C3, C5-C6, C8-C9 C2*, C4*, C7*	Murata Electronics	GRM155R71C104KA88D
CONN, SMA, END LNCH, UNIV, HYB MNT, FLT	J1-J2	HEILIND ELECTRONICS	PER MAT-21-1038
RES, 0Ω, 0402	R1-R2	Kamaya, Inc	RMCI1/16SJPTH
CONN, HDR, ST, PLRZD, 9-PIN	P1	ITW Pancon	MPSS100-9-C
RFLA1018 Module	U1	RFMD	RFLA1018

Note: Parts with \* following the Reference Designator should not be populated on PCBA.

## Evaluation Board Assembly Drawing

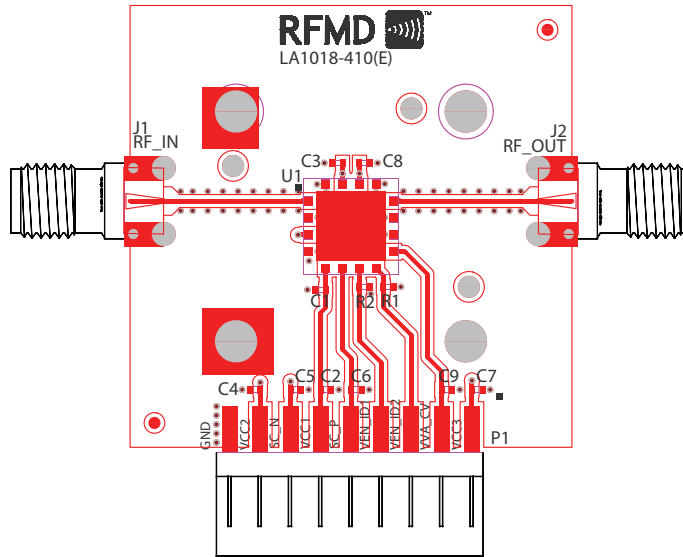

### Pin Names and Descriptions

Pin	Name	Description
1	RFIN	RF Input; Internally 50Ω Matched and DC Blocked
2	GND	Connect to Low Inductance Path to Ground
3	SC_N	Switch Control Line; See Truth Table
4	GND	Connect to Low Inductance Path to Ground
5	VCC2	VCC Supply, 10nF Decoupling Internal; Supply Voltage to 2nd Stage LNA; Disable VCC Supply in Bypass Mode to Save DC Current.
6	SC_P	Switch Control Line; See Truth Table
7	ID1/GND	Pin Grounded in Module
8	ID2/GND	Pin Grounded in Module
9	VVA_CV	Voltage Variable Attenuator Control Line; 0-3.3V Range; Max Gain is at 0V.
10	GND	Connect to Low Inductance Path to Ground
11	GND	Connect to Low Inductance Path to Ground
12	RFOUT	RF Output Internally 50Ω Match and DC Blocked
13	GND	Connect to Low Inductance Path to Ground
14	VCC3	VCC Supply, 0.1uF Decoupling Internal. Supply Voltage to 3rd Stage Amplifier.
15	VCC1	VCC Supply, 0.1uF Decoupling Internal. Supply Voltage to 1st Stage LNA.
16	GND	Connect to Low Inductance Path to Ground

### Truth Table

	SC_N	SC_P
High Gain	0	1
Low Gain	1	0

## Package Drawing

Dimensions in millimeters

Refer to drawing posted at [www.rfmd.com](http://www.rfmd.com) for tolerances

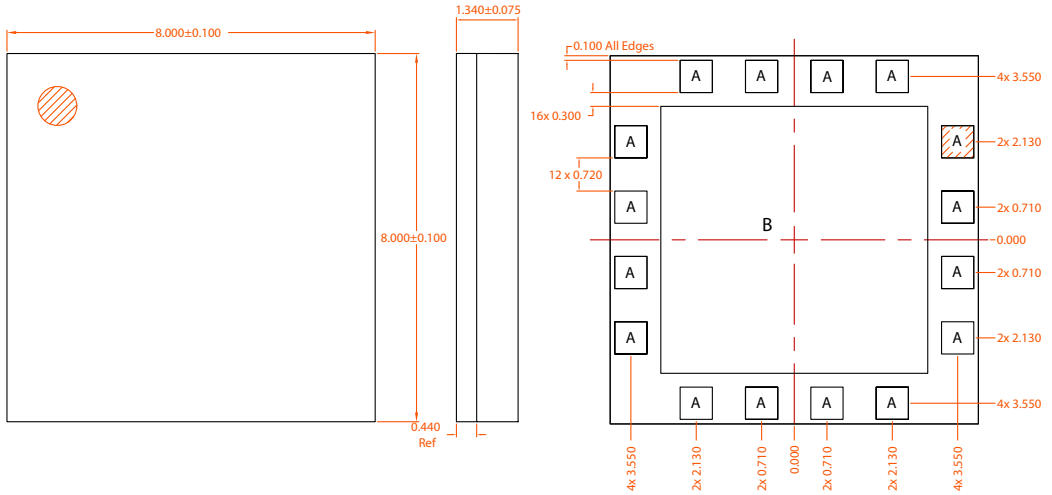

A = 0.700 x 0.700 mm  
B = 5.800 x 5.800 mm

## IO Pattern Label

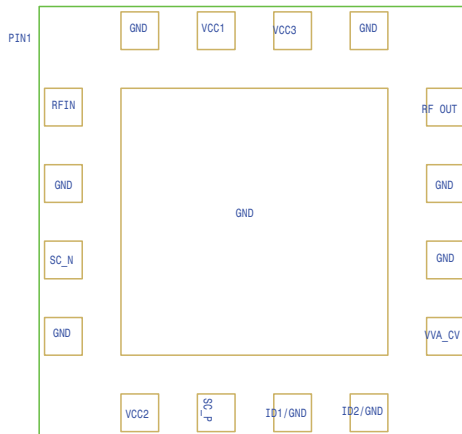

## Branding Diagram

Dimensions in millimeters

Refer to drawing posted at [www.rfmd.com](http://www.rfmd.com) for tolerances

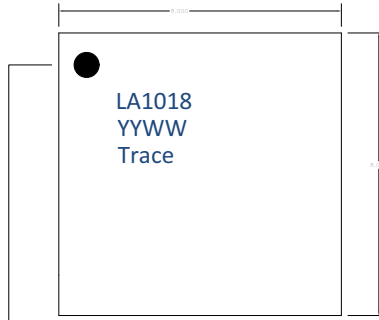

Pin 1 Indicator

YY = Year

WW = Week