

NOTES:

- USE 101-0160-01 PCB.
- CAUTION: CONTAINS PARTS AND ASSEMBLIES SUSCEPTIBLE TO DAMAGE BY ELECTROSTATIC DISCHARGE (ESD)

DO NOT SCALE DRAWING		CONTRACT NO.		PEREGRINE SEMICONDUCTOR	
MATERIAL		DRAWN JEFF LUNDY	DATE 4-20-10	9380 Caroll Park Drive San Diego, CA 92121	
FINISH		ENGINEER GARY WU	DATE 4-20-10	PE97632 DSM Fractional-N PLL EK Board (UP/Down)	
SIMILAR TO		CHECKED	DATE	SIZE	CAGE CODE
MARKING SYMBOL		APPROVED	DATE	DWG NO.	REV
		ISSUED	DATE	102-0373	04
			DATE	SCALE:	DATE
				Sheet 1 of 2	

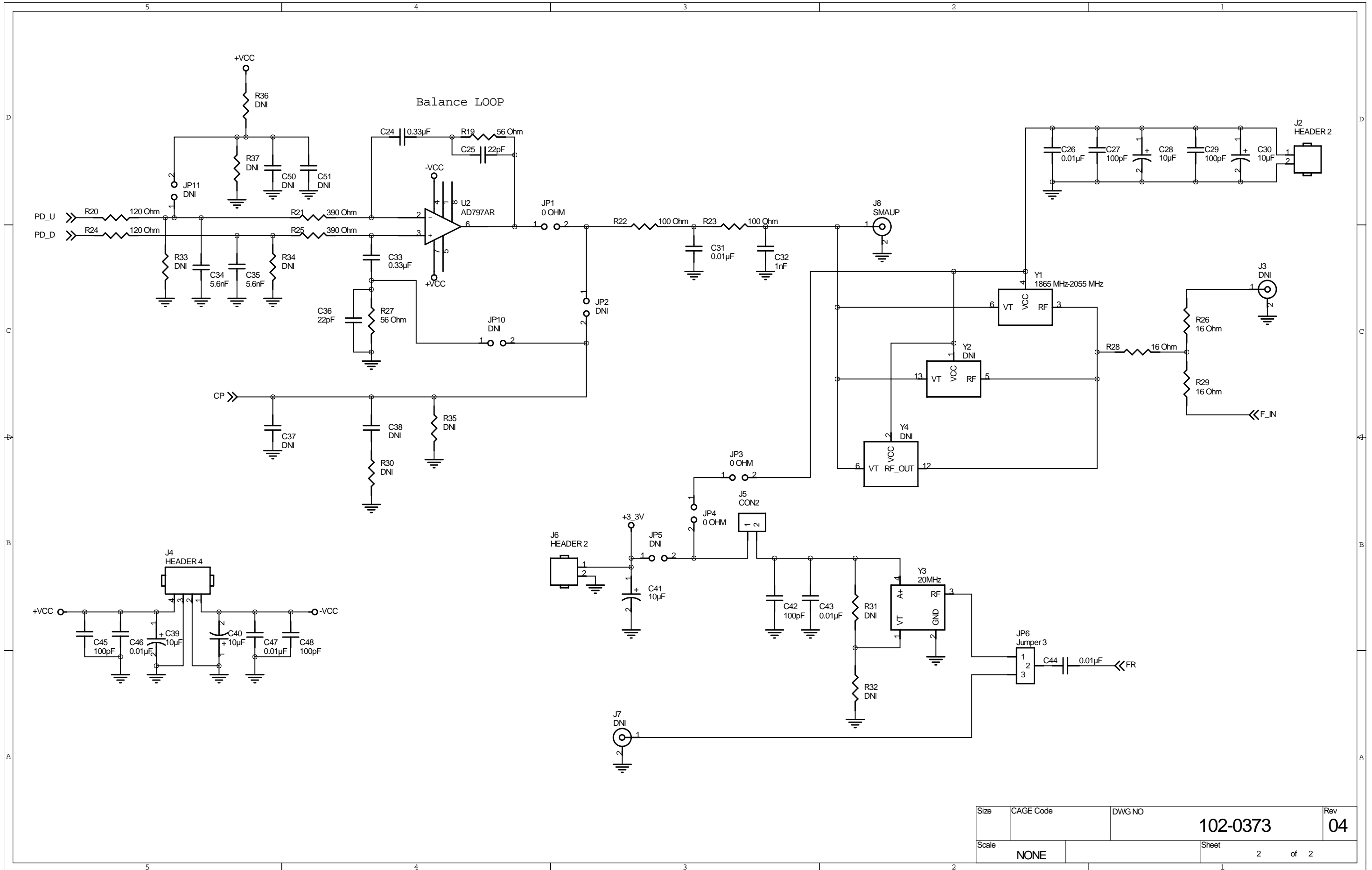

Size	CAGE Code	DWG NO	102-0373	Rev	04
Scale	NONE	Sheet	2	of	2

Item	Qty	Reference	Value	Part Description	Peregrine P/N	Manufacturer	Manufacturer Part Number	Distributor	Distributor Part Number	Data Sheet	Notes
1	1	U2	AD797AR	Analog Devices, Ultralow Distortion, Ultralow Noise Op Amp, SOIC8		Analog Devices		Digi-Key			
2	6	C5 C28 C30 C39-41	10µF	PAN SMD Capacitor, Tantalum, 10µF, 25V, TEH, 125°C, ±20%, 7343-31 (EIA)		Panasonic - ECG		Digi-Key			
3	2	CA1-2	100pF	PAN Chip Capacitor Array, 100pF, 25V, ±10%, 1206		Panasonic - ECG		Digi-Key			
4	11	C6 C9 C12 C15 C18 C21 C26 C43-44 C46-47	0.01µF	PAN SMD Capacitor, Ceramic, 0.01µF, 50V, X7R, ±10%, 0805		Panasonic - ECG		Digi-Key			
5	2	C24 C33	0.33µF	PAN SMD Capacitor, Ceramic, 0.33µF, 16V, X7R, ±10%, 1206		Panasonic - ECG		Digi-Key			Loop Filter
6	12	C1 C7 C10 C13 C16 C19 C22 C27 C29 C42 C45 C48	100pF	PAN SMD Capacitor, Ceramic, 100pF, 50V, NP0, ±5%, 0603		Panasonic - ECG		Digi-Key			
7	1	C32	1nF	PAN SMD Capacitor, Ceramic, 1nF, 50V, X7R, ±10%, 1206		Panasonic - ECG		Digi-Key			Low pass filter (with R23)
8	11	C2-4 C8 C11 C14 C17 C20 C23 C25 C36	22pF	AVX SMD Capacitor, Ceramic, 22pF, 100V, C0G (NP0), ±5%, 0603		AVX Corporation		Digi-Key			
9	2	C34-35	5.6nF	PAN SMD Capacitor, Ceramic, 5.6nF, 50V, X7R, ±10%, 1206		Panasonic - ECG		Digi-Key			Loop Filter
10	2	C37-38	DNI	PAN SMD Capacitor, Ceramic, 1206		Panasonic - ECG		Digi-Key			DO NOT INSTALL
11	2	C50-51	DNI	PAN SMD Capacitor, Ceramic, 0603		Panasonic - ECG		Digi-Key			DO NOT INSTALL
12	1	C31	0.01µF	AVX SMD Capacitor, Ceramic, 0.01µF, 50V, X7R, ±10%, 1206		AVX Corporation		Digi-Key			
13	1	J5	CON2	CONN HEADER .100 SINGLE STR 36POS		Sullins Electronics Corp.		Digi-Key			Cut to 2 Pin Header .100
14	1	JP6	Jumper 3	CONN HEADER .100 SINGLE STR 36POS		Sullins Electronics Corp.		Digi-Key			Cut to 3 Pin Header .100
15	8	D1-8	2.7V	PAN Diode Zenner, 2.7V 150MW, 200mA, S-MINI 2P		Panasonic - SSG		Digi-Key			
16	2	J2 J6	HEADER 2	CONN HEADER, W/ FRIC LCK, 2POS, .100 VERT TIN		Molex/Waldom Electronics Corp.		Digi-Key			
17	1	J4	HEADER 4	CONN HEADER, W/ FRIC LCK, 4POS, .100 VERT TIN		Molex/Waldom Electronics Corp.		Digi-Key			
18	2	JP1 JP3	0 OHM	Xicon SMD Thick Film Chip Resistor, 0 Ohm, 1/16W, ±5%, RoHs, 0603		Xicon		Mouser Electronics			
19	1	JP4	0 OHM	Xicon SMD Thick Film Chip Resistor, 0 Ohm, 1/16W, ±5%, RoHs, 0603		Xicon		Mouser Electronics			DO NOT INSTALL
20	7	JP2 JP5 JP7-11	DNI	0603 Jumper				Digi-Key			
21	1	D9	DNI	0805 LED		Osram Opto Semiconductors Inc.					
22	1	Y3	20MHz	Vectron International, Ultra miniature TCXO, 5VDC ±5% <2 mA MAX, 20MHz		Vectron International		RD&D			
23	1	U1	PLCC68	Mill-Max PLCC Surface Mount Compact Sockets, 68 POS, TIN PLATED		Mill-Max Manufacturing Corp.		Digi-Key			
24	1	R11	0 Ohm	PAN SMD Resistor, Thick Film, 12 Ohm, 1/10W, ±5%, 0603		Panasonic - ECG		Digi-Key			2 dB pad
25	2	R22-23	100 Ohm	PAN SMD Resistor, Thick Film, 100 Ohm, 1/10W, ±0.1%, 0805		Panasonic - ECG		Digi-Key			Low pass filter (with C31,C32)
26	2	R20 R24	120 Ohm	PAN SMD Resistor, Thick Film, 120 Ohm, 1/10W, ±0.1%, 0805		Panasonic - ECG		Digi-Key			
27	3	R26 R28-29	16 Ohm	PAN SMD Resistor, Thick Film, 16 Ohm, 50V, 1/8W, ±5%, 0805		Panasonic - ECG		Digi-Key			Power splitter
28	2	R21 R25	390 Ohm	PAN SMD Resistor, Thick Film, 390 Ohm, 75V, 1/16W, ±0.1%, 0603		Panasonic - ECG		Digi-Key			
29	1	R9	51 Ohm	PAN SMD Resistor, Thick Film, 51 Ohm, 1/10W, ±5%, 0603		Panasonic - ECG		Digi-Key			
30	1	R10	51 Ohm	PAN SMD Resistor, Thick Film, 470 Ohm, 1/16W, ±5%, 0603		Panasonic - ECG		Digi-Key			2 dB pad
31	2	R19 R27	56 Ohm	PAN SMD Resistor, Thick Film, 56 Ohm, 1/10W, ±5%, 0805		Panasonic - ECG		Digi-Key			
32	5	R7 R31-32 R36-37	DNI	PAN SMD Resistor, Thick Film, 0603		Panasonic - ECG		Digi-Key			DO NOT INSTALL
33	4	R34-35 R30 R33	DNI	PAN SMD Resistor, Thick Film, 0805		Panasonic - ECG		Digi-Key			DO NOT INSTALL
34	1	R12	DNI	PAN SMD Resistor, Thick Film, 470 Ohm, 1/16W, ±5%, 0603		Panasonic - ECG		Digi-Key			2 dB pad
35	1	R8	220	CTS Thick Film Chip Resistor Chip Array 16TRM, 8RES, 220 Ohm, 50V, 742, 0.063W, ±5%, 0603		CTS Corporation Resistor/Electrocomponents		Digi-Key			
36	6	R13-18	10K	CTS Thick Film Chip Resistor Chip Array 16TRM, 8RES, 10K, 50V, 742, 0.063W, ±5%, 0603		CTS Corporation Resistor/Electrocomponents		Digi-Key			
37	6	R1-6	220	CTS Thick Film Chip Resistor Chip Array 16TRM, 8RES, 220 Ohm, 50V, 742, 0.063W, ±5%, 0603		CTS Corporation Resistor/Electrocomponents		Digi-Key			
38	2	J3 J7	DNI	SMA 500 END LAUNCH JACK RECEPTACLE-ROUND CONTACT		Johnson Components Inc.		Digi-Key			DO NOT INSTALL
39	1	J8	SMAUP	SMA 500 RECEPTACLE STRAIGHT PCB		Amphenol-RF Division		Digi-Key			
40	1	J1	HEADER 26	CONN HEADER .100 DUAL STR 72POS		Sullins Electronics Corp.		Digi-Key			Cut to 26 Pin Header .100
41	6	S1-6	106-1208-EV	Mountain Switch, SPST, DIP SW 8 POS, NS 100mA/50VDC, S 50mA/24VDC, RoHs		Mountain Switch		Mouser Electronics			
42	3	TP1-3	Testpoint	CONN HEADER .100 SINGLE STR 36POS		Sullins Electronics Corp.		Digi-Key			Cut to 1 Pin Header
43	10	TP4-5 X1-8	T POINT A								
44	1	Y2	DNI	Micronetics VCO, 2GHz-3.2GHz		Micronetics		Micronetics			
45	1	Y1	1865 MHz-2055 MHz	Micronetics VCO for WLL Handset Applications, 1.865GHz-2.055GHz		Micronetics		Micronetics			
46	1	Y4	DNI	Micronetics VCO, 2970 - 3190 MHz		Micronetics		Micronetics			
47	1	PCB, 101-0160-01									