

Low Power Management Unit with MC34700

Demo Board Description

by: Stanislav Arendárik,
Freescale Application Engineer,
Rožnov, Czech Republic

1 Introduction

In the future, low power consumption will become more and more important in a wide range of electronic appliances. Thus power conversion must be realized with as high a level of efficiency as possible. Many of those appliances, like set top boxes (STB), TV sets, and others, stay in standby mode if not used. The power consumption must also be as low as possible. Freescale Semiconductor brings a comprehensive solution that combines high efficiency of the DC/DC conversion in run mode with very low power consumption in standby mode.

The DC/DC converter MC34700 acts as a four-output DC power supply. The control unit is managed by a very low power MCU. In this demo, the MC9RS08KA2 or MC9S08QE8 are used.

Contents

1	Introduction	1
2	MC34700 Features Overview	2
3	Block Diagram of System	2
4	Demo Board Description	3
4.1	Input Filter and LCD Meter Function	3
4.2	DC/DC Converter Function	4
4.3	Control MCU Function	4
4.4	MCU Function of STB	5
4.5	IR Receiver, Standby Button, and Other In-Out Options	5
5	Software Description	6
5.1	Control MCU Software Description	6
5.2	MCU Software Description of STB	8
6	Schematic	8
7	DC/DC Converter Layout	12
8	Conclusion	14
9	Addendum	15
9.1	Practical Design Example	15
9.2	Conclusion	20

2 MC34700 Features Overview

The block diagram of this converter is shown in [Figure 1](#).

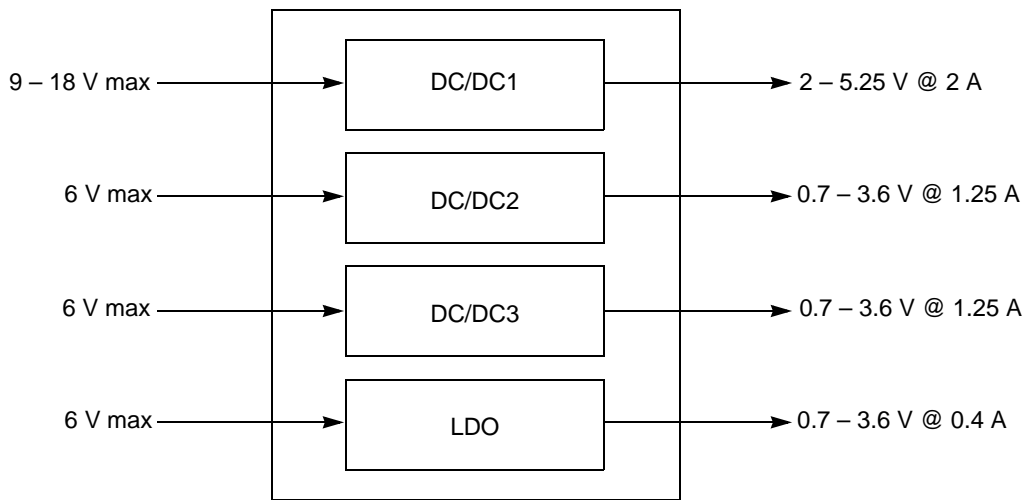

Figure 1. MC34700 Block Diagram

The converter consists of four partial DC/DC converters. They each have different features, as shown in [Figure 1](#). The first (DC1) is a non-synchronous converter; thus an external Schottky diode is required. The next two are identical synchronous converters, satisfying high efficiency conversion needs. The last one is a low drop output regulator (LDO). All the converters have specially controlled switching to reduce the system noise. A wide range of output voltage is intended to meet the demands of a wide spectrum of user applications. All converters incorporate all protection and monitoring features, in other words, OCP, OVP, UVLO, thermal shut down, and power monitoring.

You can use various configurations to source the partial DC/DC converters. The most usual way is to use one non-regulated DC source of voltage in a range from +9 V to +18 V. In this way both DC1 and DC2 converters can be powered by DC1. This means that the output of the DC1 converter is connected to the inputs of the DC2 and DC3 converters. The LDO can be powered by DC1 too, or it can be powered by one of the DC2 or DC3 converters. The exact configuration depends on the requirements of the final application.

You can find more detailed information about this converter in the datasheet.

3 Block Diagram of System

The overall block diagram of the demo board is shown in [Figure 2](#).

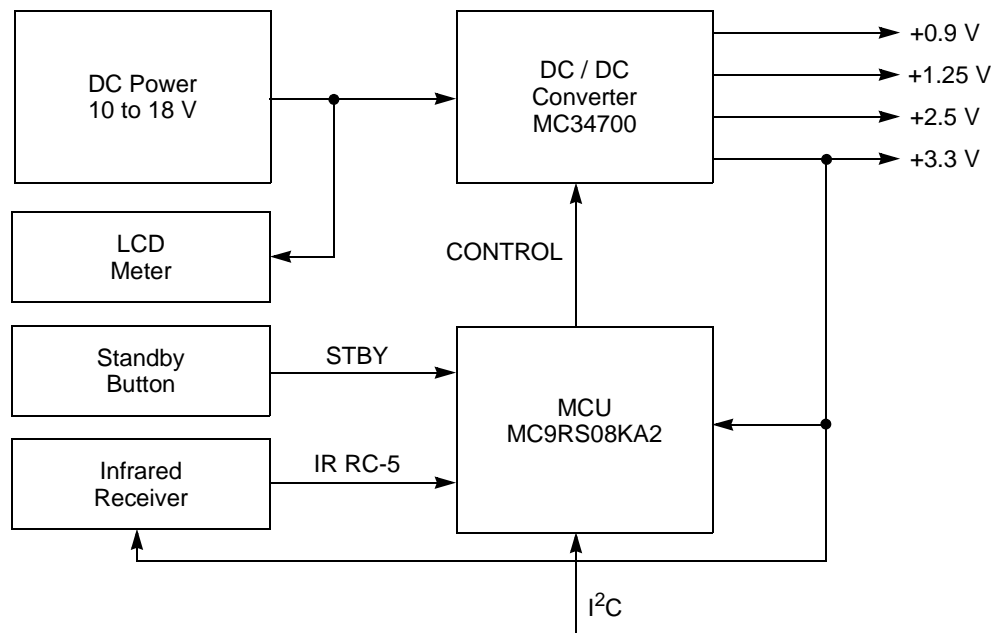

Figure 2. Block Diagram

The whole demo board consists of the following parts:

- DC power section — contains the DC input filter
- LCD meter — measures the supply current of the DC/DC converter in run or standby mode
- DC/DC converter MC34700 — main part of this board
- MCU MC9RS08KA2 (or MC9S08QE8) — controls the whole behavior of the DC/DC converter
- MCU MC9S08QG8 — acts as STB's MCU; communicates with PC by serial link
- Standby button — serves as input for manual on/off control
- Infrared receiver — continuously sensitive for incoming infrared signal from the standard remote control

4 Demo Board Description

4.1 Input Filter and LCD Meter Function

The main role of the DC input filter is to avoid the propagation of high-frequency products from the DC converter back to the main power supply line. It consists of the capacitors C20, C21, C22, and inductor L2. The next part of this section is the dedicated power supply for the LCD meter. The LCD meter needs an isolated power supply for proper functionality. This power supply consists of the U13 and associated circuitry. It produces DC voltage of +9 V sufficient for the LCD meter.

The LCD meter measures the DC input current into DC/DC converter MC34700. This current flows through the 100 mΩ sense resistor. This current is shown in mA on the LCD meter.

4.2 DC/DC Converter Function

The main part of this board is the DC/DC converter. The converter provides three channels of high efficiency DC/DC converters (DC1, DC2, DC3) and one LDO. The main output voltage level of the DC1 is in a range up to +5 V and up to 2 A of the output current. For this application, it is set to +3.3 V. The next converters, DC2 and DC3, can provide output voltage up to max +3.6 V with the current capability up to 1.25 A. Their outputs are set to +2.5 V and +1.25 V respectively. The last one is the LDO, which is set to +0.9 V. It can deliver up to 400 mA of output current. You can find comprehensive technical information in the MC34700 datasheet.

All outputs of the mentioned partial DC converters are connected to 2-pin output headers, and the presence of the output voltage levels is signaled by LEDs. The DC1 converter runs when the board is switched on. Other converters can be controlled autonomously, in accordance with user requirements.

4.3 Control MCU Function

The MCU MC9RS08KA2 or MC9S08QE8 is the control unit of the whole board. You can choose between MC9RS08KA2 or MC9RS08QE8 MCU using the switch SW4. Both MCUs fulfill the same functionality in this design. They work in two main states — stop mode and run mode. The complete functionality is shown in the state diagram in [Figure 3](#).

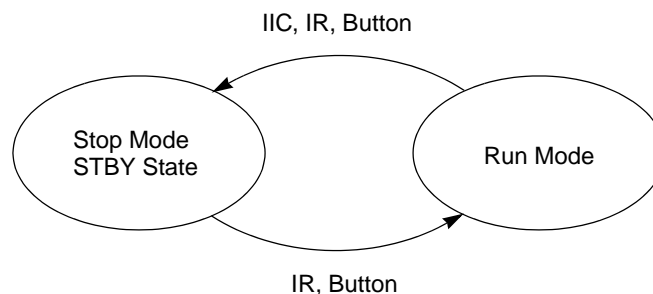

Figure 3. State Diagram

Stop mode is the default mode after power-up of the whole board. As [Figure 3](#) shows, when the board is powered up by the off/on switch (SW3), the DC/DC converter starts to run. It provides the main output power supply of +3.3 V. This is the power supply for the selected control MCU (MC9RS08KA2 or MC9RS08QE8) and for the infrared receiver U4. Right after the power-up sequence, the MCU sets its internal state to be sensitive to the standby button and data from the IR receiver, switches the DC/DC converter off, and goes into stop mode. Power consumption is as low as possible. While the MCU is in stop mode, it is pooling for the wakeup signal from the standby button or IR receiver. The first edge of those signals wakes the MCU.

The MCU in run mode recognizes which of the valid input signals was received and performs the appropriate operation. When the standby button is pressed, the MCU accepts this signal and sends the power on control signal to the DC/DC converter to enable all requested partial DC/DC converters. If the IR remote control is used to wake the demo board, the onboard IR receiver sends the received data into the control MCU. The MCU recognizes whether this command is valid to wake the board. If this signal is valid, the MCU wakes the DC/DC converter and enables the main power supply +3.3 V to source the

STB's MCU, which is represented by an MC9S08QG8 MCU on this demo board. The STB power LED illuminates.

In run mode, the selected control MCU (MC9RS08KA2 or MC9RS08QE8) is also sensitive to commands by the IIC bus. This bus connection is intended for the STB's MCU access to control the MCU. The STB's MCU usually sends the power off command to switch off the whole STB (or some other appliance like a TV set, etc.). The control MCU is sensitive to the standby button and the IR receiver's data. It is possible to put the demo board into the off state by pressing the standby button or by sending the power off command by remote control unit. In application SW for the control MCU, you can select which of all IR remote commands will be used to wake or switch off the whole appliance.

4.4 MCU Function of STB

In this application, for demo purposes, the MC9S08QG8 type of MCU is used as a replacement for the main MCU of the whole appliance (STB, TV set, or some other). This MCU replaces the IIC bus functionality of the main MCU — it sends the ready message by serial link to a connected PC after wakeup, and receives the off command from the hyperterminal application on PC. It then sends the switch off command to the control MCU by IIC bus. The control MCU recognizes this command and switches off the DC/DC converter. The main power supply +3.3 V stays active, and the control MCU (MC9RS08KA2 or MC9RS08QE8) goes into stop mode to minimize power consumption.

4.5 IR Receiver, Standby Button, and Other In-Out Options

The IR receiver and standby button are part of the main interfaces on this demo board. The next possibly used interfaces are the standard GPIO port on the header JP7 and the output of the main control signal of the whole DC/DC converter on the header JP2. The standard GPIO port can be used as the input/output from/to any wireless module. The +3.3 V supply voltage is connected to the JP7 header for this option.

The external standby button acts as the optional replacement for the onboard button. You can connect this external button to the header JP3 — this is the parallel connection to the button SW2. The next option to consider is connecting the external IR receiver to the header JP4. This external IR receiver must meet the basic requirement — it must be able to work with +3.3 V supply voltage. The carrier frequency can differ in accordance with the final application. The 36 kHz carrier frequency is used on this demo board.

There are some other features on the board. One of them is the IIC bus connected on the header JP8. This port also provides the supply voltage +3.3 V for the external application. This header can be used as a primary connection to the main MCU in an external appliance.

The next features are several LEDs intended to indicate activity on the IIC bus (SDA and SCL lines), the PGOOD signal from the DC/DC converter, and activity on the IR receiver output. You can enable or disable these features by the jumpers on header JP13. The next three LEDs are used to show the activity of the control MCU — MC9RS08KA2 or MC9S08QE8 (LEDs LD5, LD7) and the presence of the main +3.3 V supply voltage (LED STB Power) on header JP8.

All three MCUs have their own standard BDM interfaces on board in their own sections. Both control MCUs have their pins outlined to appropriate headers.

5 Software Description

There are three MCUs on the board. Two of them have quite similar functionality — MC9RS08KA2 and MC9S08QE8. The last one, MC9S08QG8, simulates the function of the main MCU of the final application. The source code for all three MCUs is provided as the AN3592SW.zip file.

5.1 Control MCU Software Description

The flowchart of the control MCUs MC9RS08KA2 and MC9S08QE8 is shown in [Figure 4](#). When the main switch on the board (SW3) is switched on, the DC/DC converter starts to run and the DC1 converter provides +3.3 V output voltage. Other partial converters also start to rise. The selected control MCU performs the initialization sequence, prepares for stop mode, switches off all partial converters excluding DC1, and goes into stop mode to minimize power consumption. In this state only the DC1 converter is active, and the control MCU with IR receiver is powered. The MCU is sensitive to the press of the standby button and receives the command from the remote control unit.

When the remote control unit sends the command, the MCU awakens, receives the command, and recognizes what this command means. All the remote commands are sorted into two groups with two main results — switch on or switch off the DC/DC converter. Then the MCU performs the requested operation.

When the standby button is pressed, the MCU awakens and changes the state of the DC/DC converter from off to on or vice versa.

When the DC/DC converter is in the on state, the control MCU is in the run mode and is sensitive to IIC bus commands from the main MCU of the appliance. It is also possible to switch off the whole appliance through the IIC command.

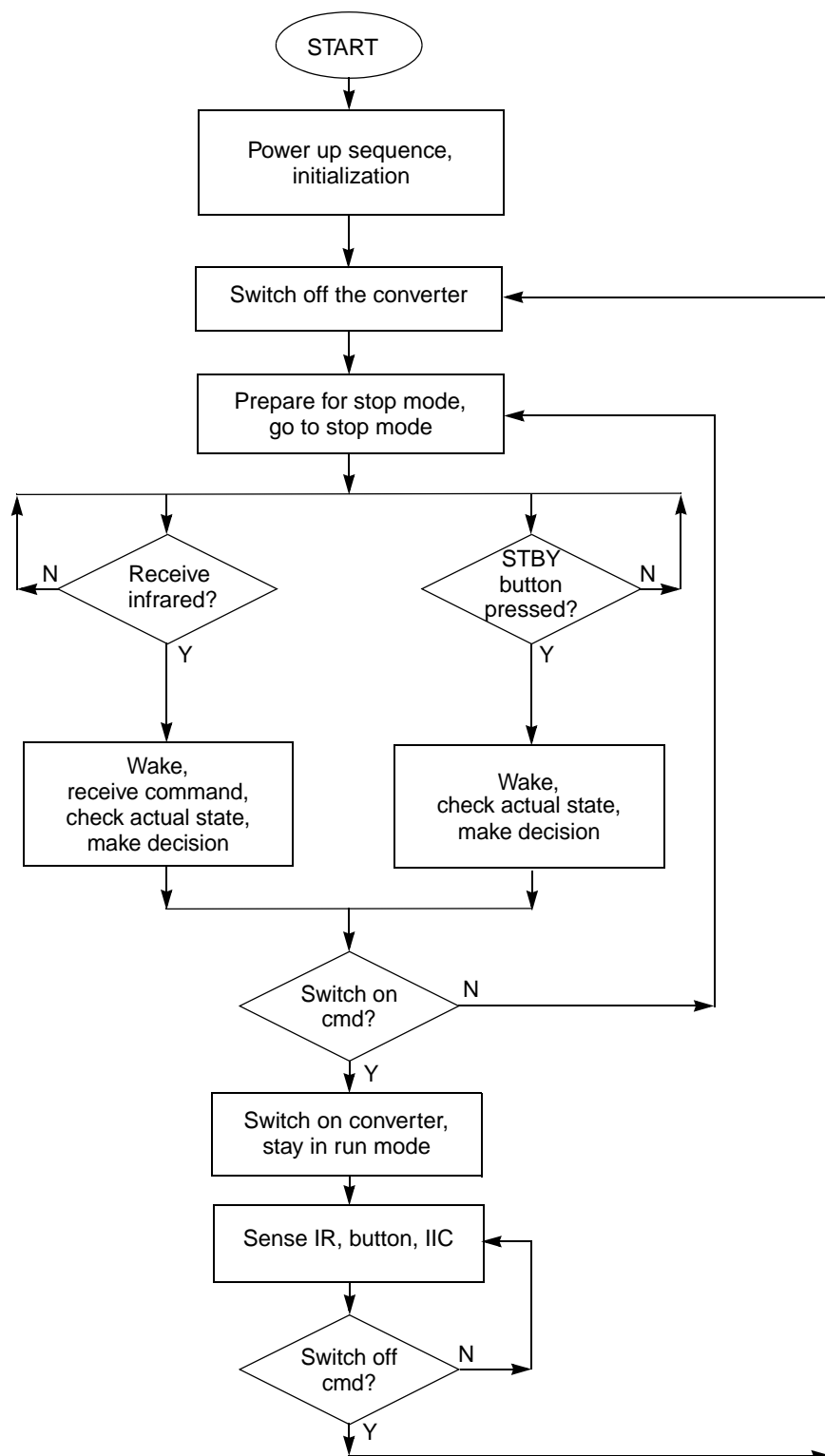

Figure 4. Control MCU Software Flowchart

5.2 MCU Software Description of STB

The MC9S08QG8 MCU is on position U5. This MCU simulates the STB's MCU function. When the DC/DC converter is in the active state, the MCU sends the message to the PC's hyperterminal. You can type S or s or press the Space bar on the PC's keyboard to simulate a request, which puts the demo board into a standby state. This MCU receives this request from the PC and sends the command by the IIC bus to the control MCU. The control MCU recognizes this command and switches the DC/DC converter off. Then the demo board stays in the standby mode.

6 Schematic

The schematic of this board is split into three parts: the DC/DC converter is shown in [Figure 5](#), inputs and outputs are shown in [Figure 6](#), and control MCUs with associated circuits are shown in [Figure 7](#).

The DC/DC converter is attached to the recommended connection. The LEDs with associated circuits are used to show the active state of partial converters. These circuits can be omitted in the final application. All other components used are able to work in the full range of enabled loads.

The inputs and outputs are created by using standard components. Pay attention to proper IR receiver selection. It must comply with the power supply voltage level (+3.3 V in this case) and use a modulation frequency of the remote control (36 kHz in this case). It is possible to use an external IR receiver with different carrier frequency connected to the header JP4.

Two MCUs are selected as control MCU — MC9RS08KA2 or MC9S08QE8. The MC9RS08KA2 MCU can work at up to +5 V supply voltage, but MC9S08QE8 only up to +3.6 V max. Which level will be used depends on the final application.

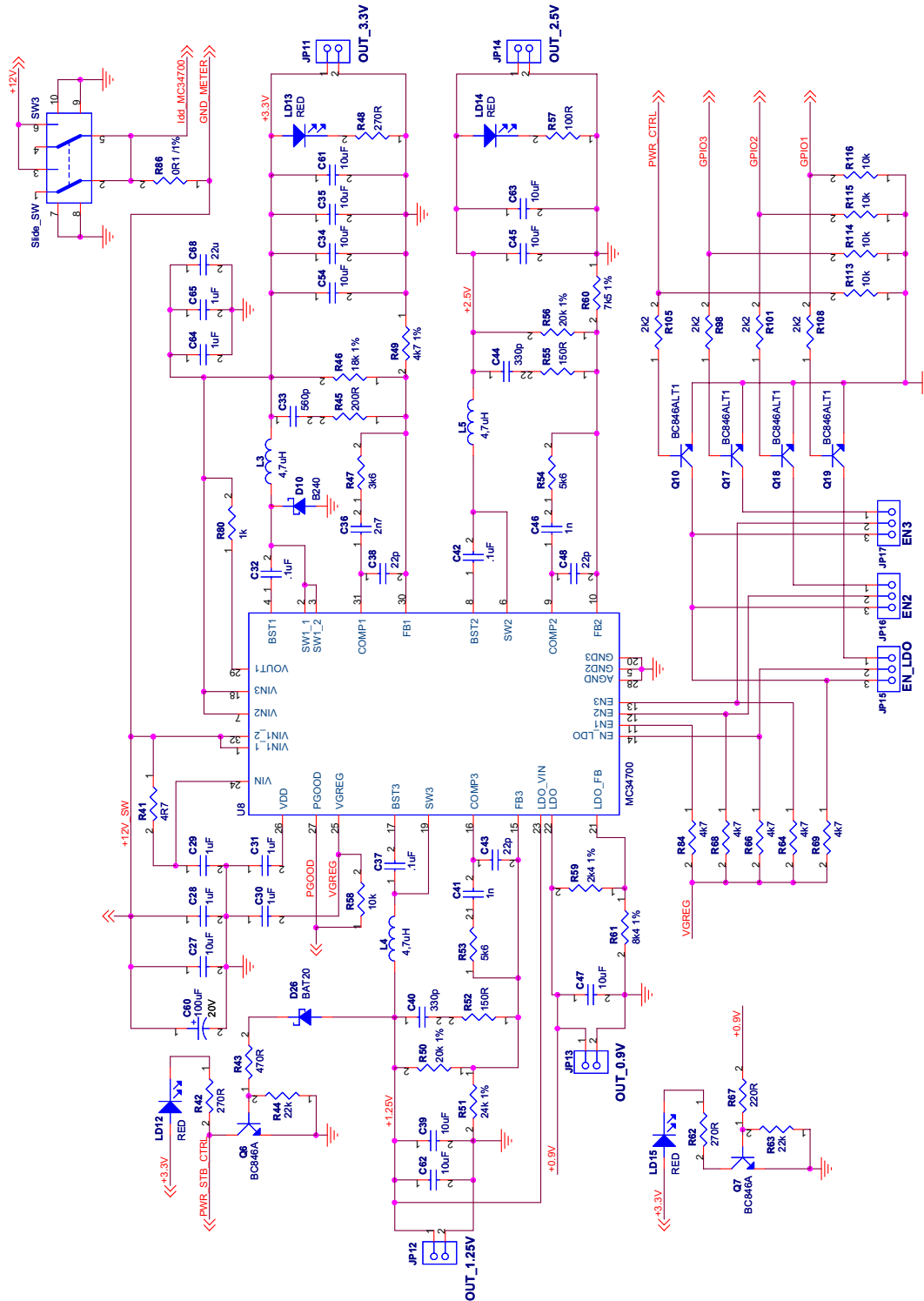

Figure 5. DC/DC Converter Schematic

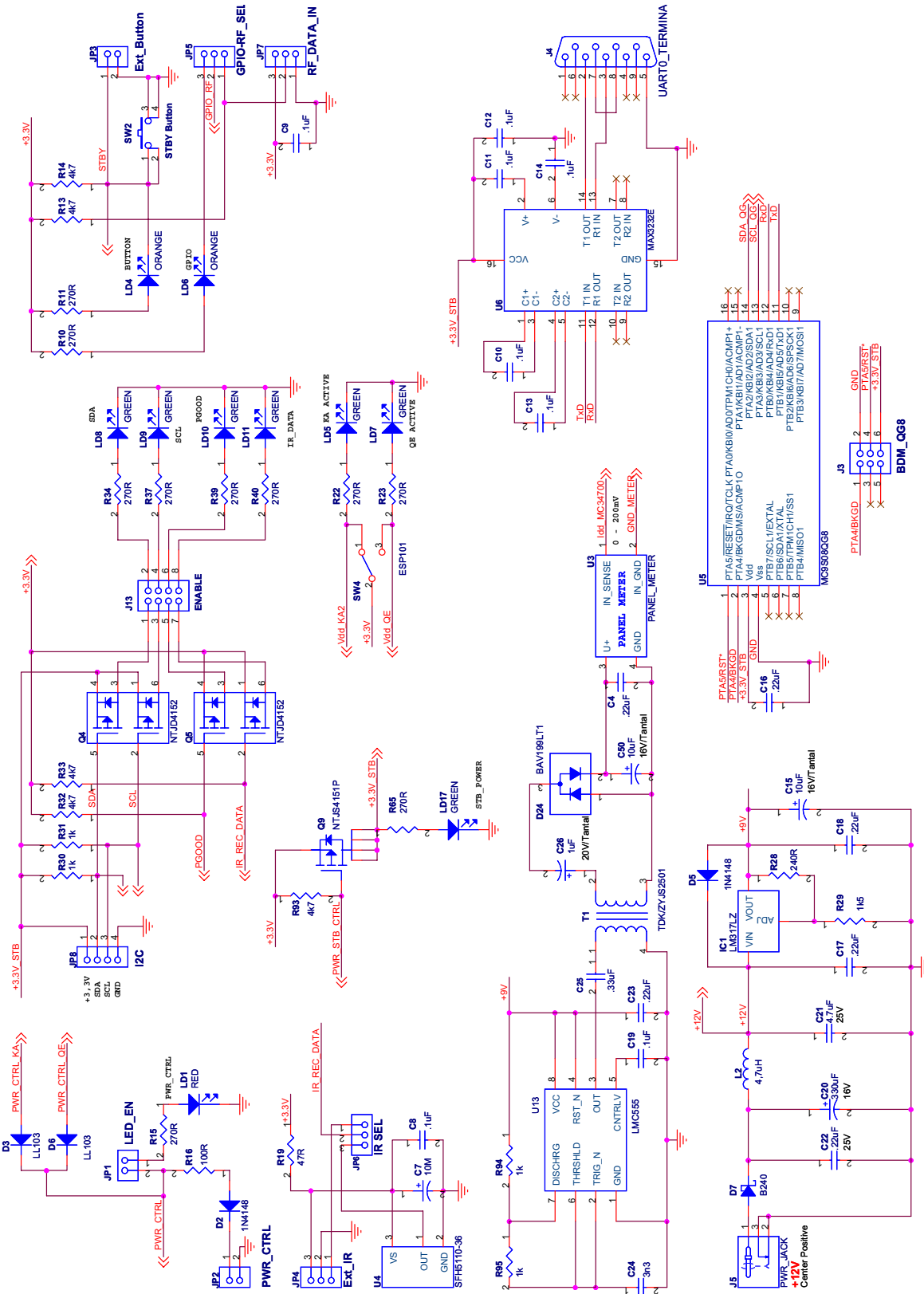

Figure 6. Power Supply for LCD Meter, Inputs, and Outputs

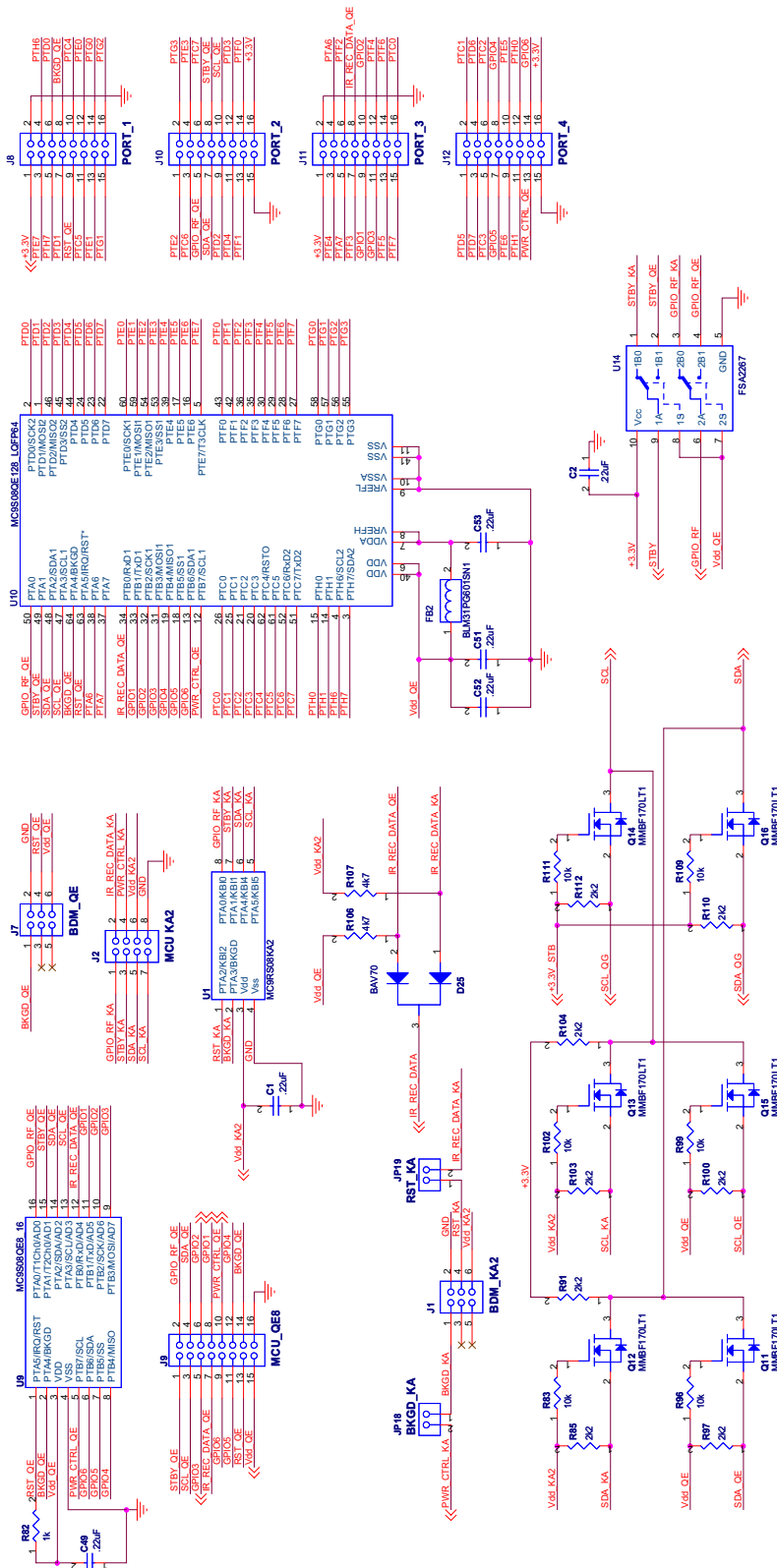

Figure 7. Control MCUs

Low Power Management Unit with MC34700, Rev. 1

7 DC/DC Converter Layout

The proper layout is very important for every DC/DC converter. We can choose between four-layer or double-layer design. The four-layer design is a lot simpler and ensures good performance of the converter. But in many applications the most important factor is the price. The double-layer design is cheaper and is also able to maintain good performance. But in this design you need to pay more attention to the correct placement of critical components. These components are mainly input blocking capacitors, output inductors and output capacitors, freewheel diodes, and feedback voltage dividers.

You also need to pay attention to correct component selection. All blocking capacitors must have very low ESR and sufficient capacity. These two contrary requirements can be fulfilled by new types of ceramic capacitors with high capacity.

The inductors used for the voltage conversion must be shielded to maintain good EMC compatibility. They must comply with the output current requirements and the thermal dissipation.

The DC/DC converter is housed in the small QFN case with the ground pad on the bottom side. This pad is intended to provide main grounding of the converter and sufficient thermal power dissipation.

An example of how to design the two-layer board for this converter is shown in [Figure 8](#) and [Figure 9](#).

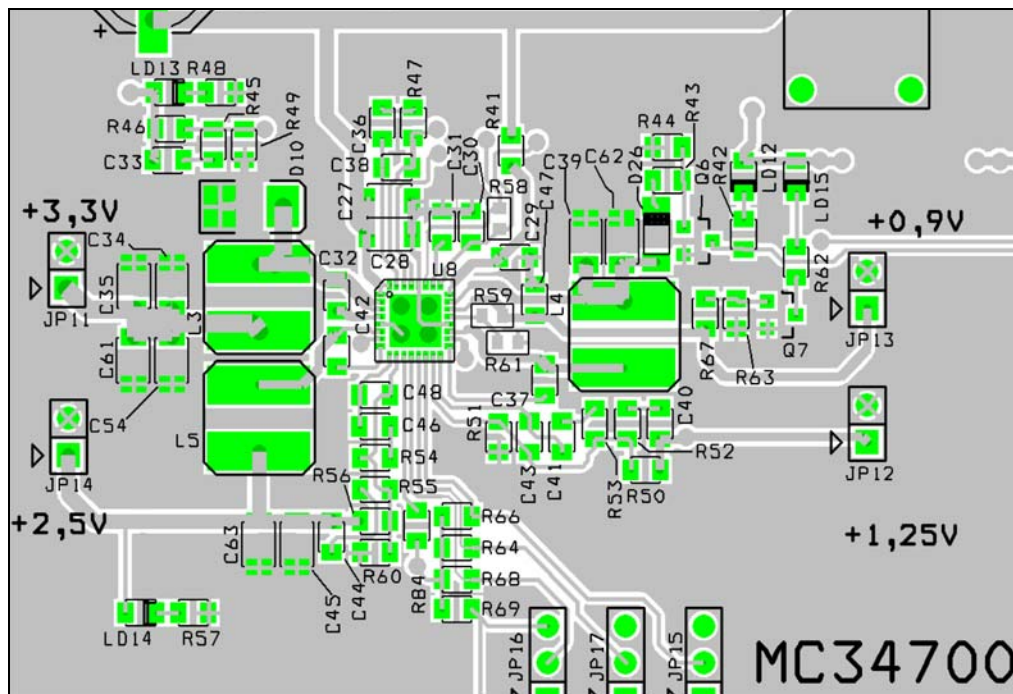

Figure 8. Example of the Converter Layout Top Side

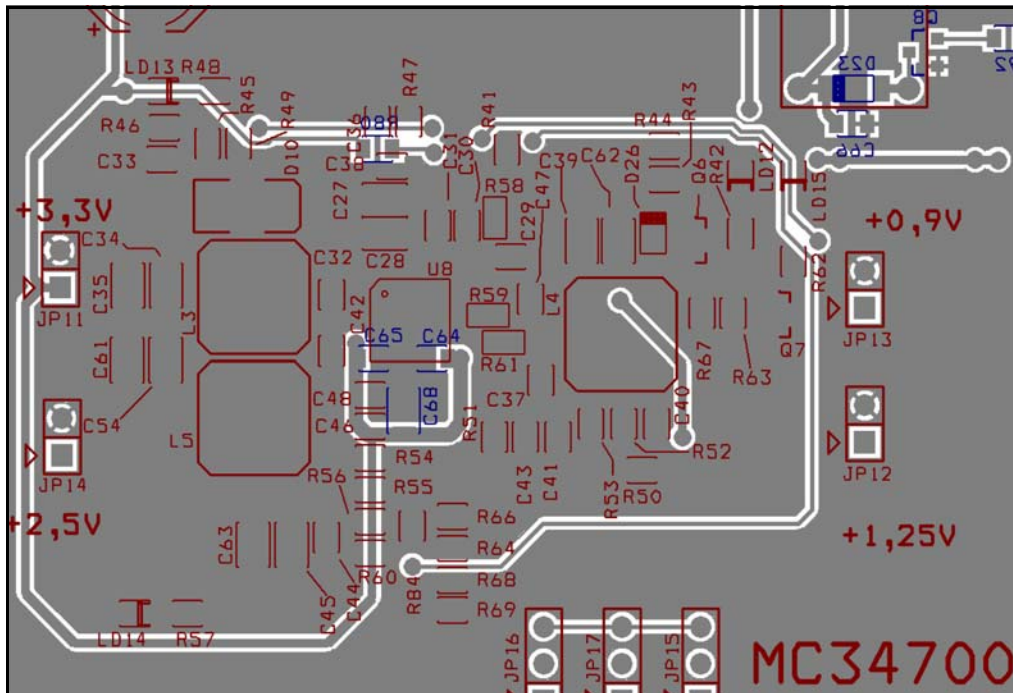

Figure 9. Example of the Converter Layout Bottom Side

It is very important in this design to maintain as large a ground area as possible. This ground must dissipate the thermal power of the converter and ensure proper current flow between the converter's ground, the Schottky diode D10, and all blocking capacitors.

The whole populated demo board is shown in [Figure 10](#). The current-sense resistor (0.1R) is populated on the bottom side directly under relay position RE4.

Key components used in this design:

- DC/DC Converter MC34700 — Freescale
- MCUs MC9RS08KA2, MC9S08QE8, MC9S08QG8 — Freescale
- Inductor L2 - MOS6020 - 68 μ H — Coilcraft
- Inductor L3, L4, L5 - SLF6028 - 4.7 μ H — TDK
- Schottky diode MBRS240LT3 — ON Semi
- Capacitor C34, C35,.... 1206YC106MAT9A — AVX

Conclusion

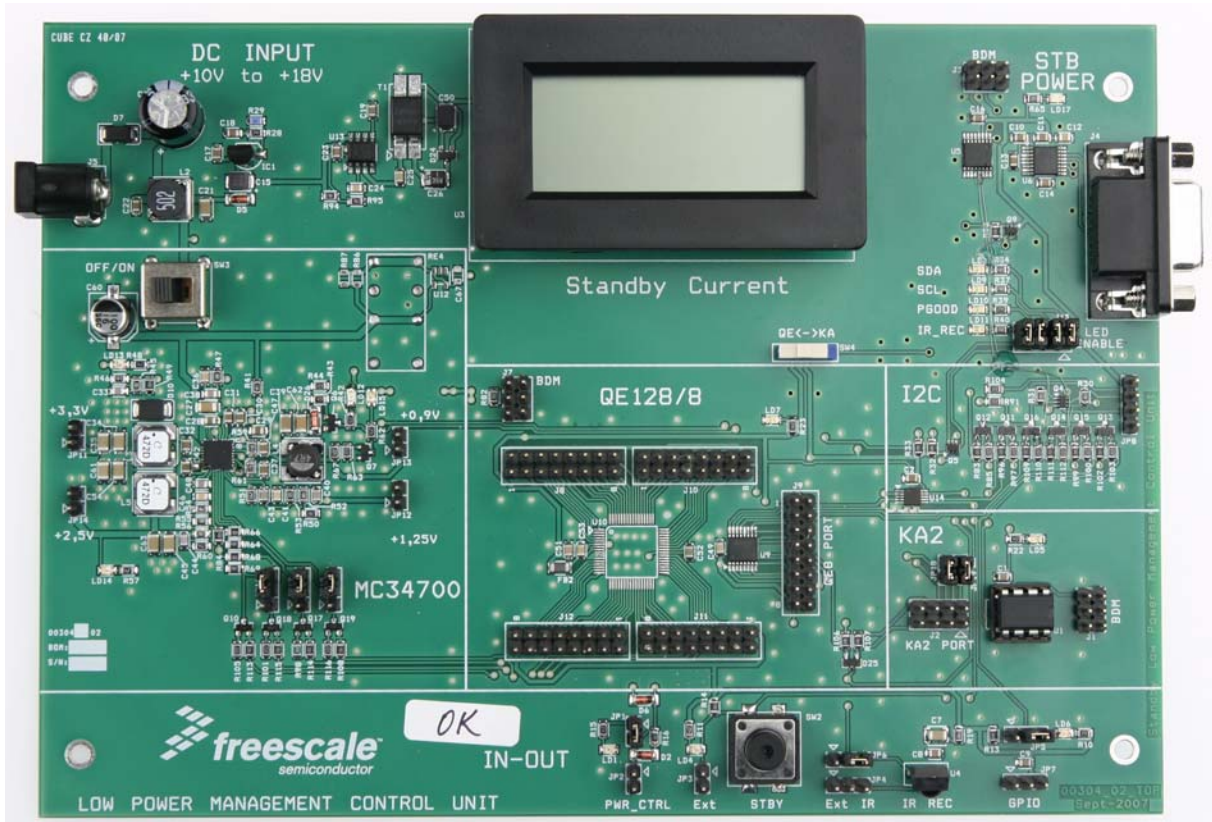

Figure 10. Demo Board

8 Conclusion

The main goal of this demo board design is to show how to use the high-efficiency multiple DC/DC converter in a wide range of applications. This power DC/DC converter is intended to provide input for a non-regulated supply in the voltage range from +10 V to +18 V. This converter provides four independent voltage sources in a range from +3.6 V max to +5 V max. This converter is controlled by the MCU. In the standby state the converter provides limited output power to supply the MCU and infrared receiver. The MCU is in a very low power stop mode. In this state, the converter is sensitive to wakeup commands generated by either the standby button or by the remote control. When the correct command is received, the MCU switches on the converter and the whole application can run. The MCU can switch on/off each partial DC/DC converter excluding DC1. This option can be used in accordance with the final application.

The advantage of using the MCU MC9RS08KA2 is very low power consumption and low price. On the other hand, the MC9S08QE8 MCU has very low power consumption, low price, and a wider range of applications. The same MCU can be used also as the main MCU in the final application. It is possible to use the QE128 type of the MCU instead of MC9S08QE8 for large systems.

9 Addendum

9.1 Practical Design Example

This design is intended to show how to build the whole DC-DC converter for real use in the customer application.

9.1.1 Main Features

This design must meet these requirements:

- Input voltage from 10 V to 18 V DC
- Output voltages:
 - 5.0 V / 1.5 A maximum
 - 3.3 V / 1.25 A maximum
 - 3.3 V / 1.25 A maximum
 - 2.5 V / 0.4 A maximum — LDO
- On/off control by standard infrared remote control
- On/off control by external standby button
- Off control by external IIC bus connection
- Possibility of an independent on/off control of each output

9.1.2 Selected Solution

According to experiences with designing DC/DC converters, a double sided PCB board with a central positioned converter was chosen. The MC9S08SG8 MCU in the TSSOP-16 package was selected as the control MCU of the whole power supply. The infrared (IR) receiver is placed on the board with all its power circuitry and both pins (power and output) wired out at the main connector. It can be placed outside the board in the final application. The input pins, output pins, and all free MCU pins are connected to the main connector — one side oriented header. This allows plugging this board into customer application in a vertical position to save space and maintain the sufficient cooling capability.

The main configuration of the converter was selected to meet the requested features. The block schematic is in [Figure 11](#). The DC1 internal converter is selected as the main converter. It converts a wide range of input voltages, ranging from 10 V to 18 V, to a stabilized output level of +5 V DC. All other partial converters DC2, DC3, and LDO, are powered by this +5 V line. Thus the whole power goes through the DC1 converter. It is important to select all components properly for this partial converter to maintain the highest efficiency possible. The LDO regulator can be powered by a lower voltage level output, for example 3.3 V output of the DC2 or DC3 converter. This can improve the whole efficiency and working temperature of the final application. The configuration shown in [Figure 11](#) was selected to make tests with a high load of all partial converters and measure the working temperature. The final customer application can use different configurations to maintain the highest efficiency and the lowest working temperature possible.

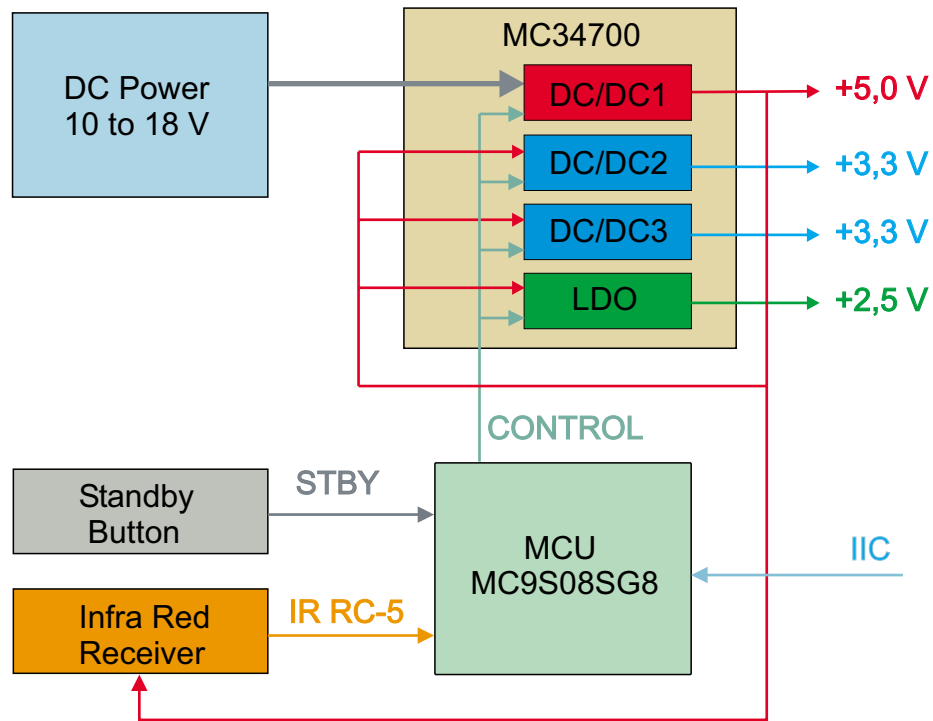

Figure 11. Power Supply Block Schematic

The infrared receiver and standby button are the external peripherals. The IIC bus is the external connection from the main MCU of the real application. The infrared receiver is assembled on the board for testing purposes, but you can use an external one without board correction. The IR RC-5 connection shown in [Figure 11](#) is realized through the main connector. The output of the +5 V line is set on or off by a MOSFET switch.

For a detailed schematic of the connection see [Figure 12](#).

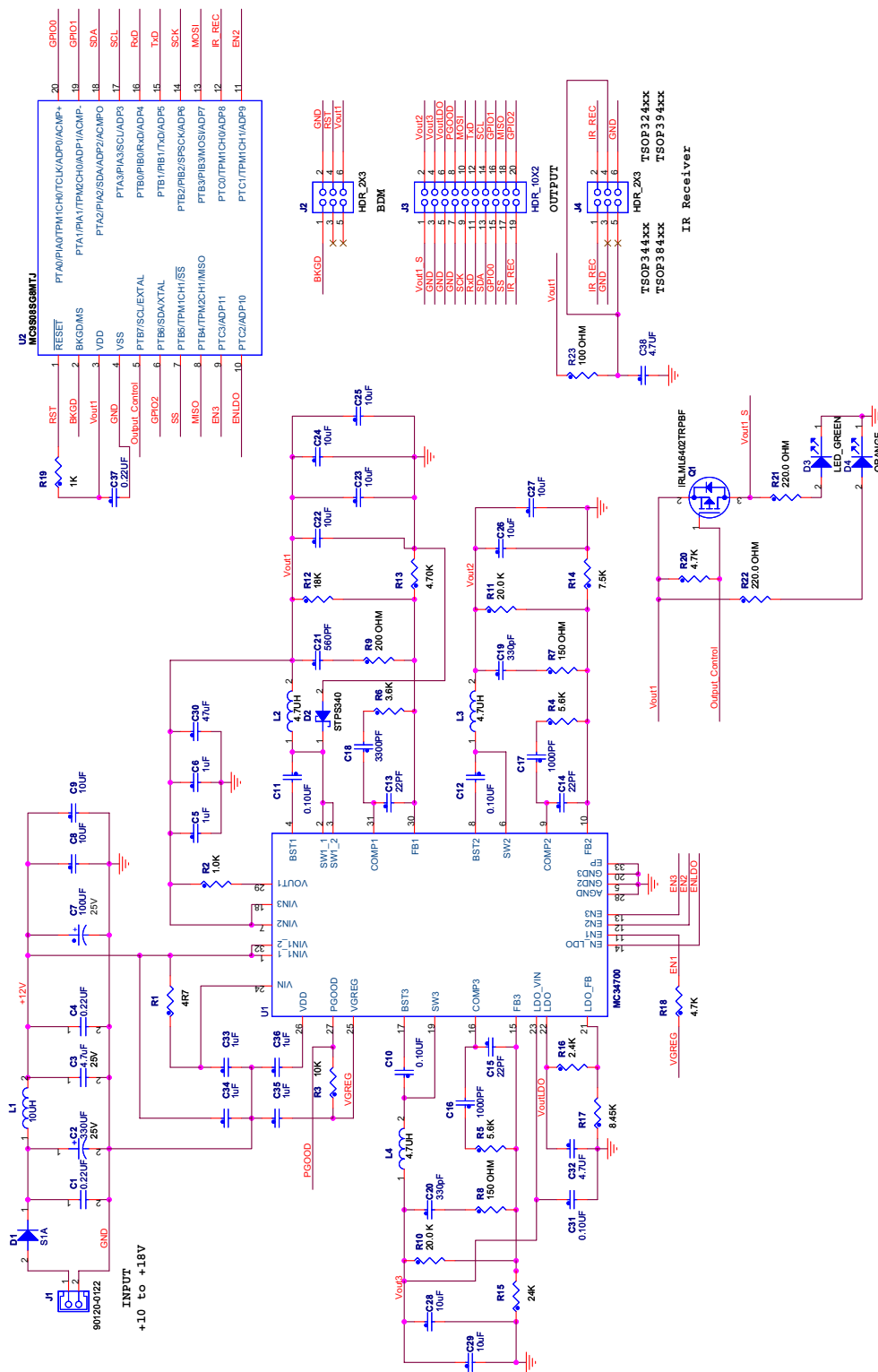

Figure 12. MC34700 Power Supply Schematic

Low Power Management Unit with MC34700, Rev. 1

9.1.3 Measured Values

Seven pieces of this converter were built. Each one was fully tested in various loads — ranging from no load to maximum load. The half load was selected as the main working point. This point was characterized by the following test conditions:

Table 1. Test Conditions — Average Values

Part / Item	Output Level [V]	Output load [Ohm]	Output current [A]
DC1	5.07	9.2	0.55
DC2	3.35	5.6	0.60
DC3	3.34	5.6	0.60
LDO	2.52	12	0.21

All converters were tested with input voltages ranging from 10 V to 18 V DC. Please note that the load current of the DC1 converter is sum of the current in [Table 1](#) and all supply currents of DC2, DC3, and LDO part. This implies from the block schematic in [Figure 11](#). The average value of the overall efficiency is in [Figure 13](#).

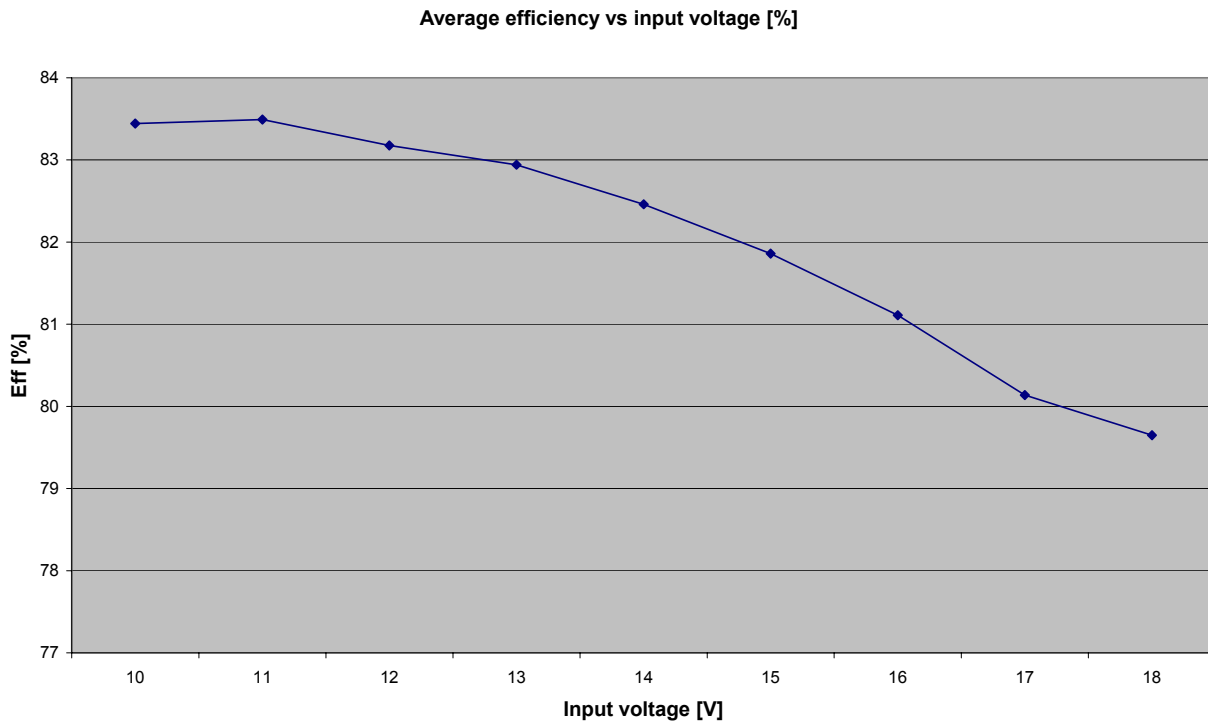

Figure 13. Average Overall Efficiency

This efficiency was measured at half load. This converter is also able to source the full output current of each part, but in this case the first converter DC1 is overloaded. This condition was tested on all boards. In this case the output current of the DC1 converter reaches up to 3 A. Be aware that in this case the internal overheat protection can be activated and whole converter can shut down.

The thermal snapshot of this board in the standby state is shown in [Figure 14](#). The ambient temperature was about 29 °C.

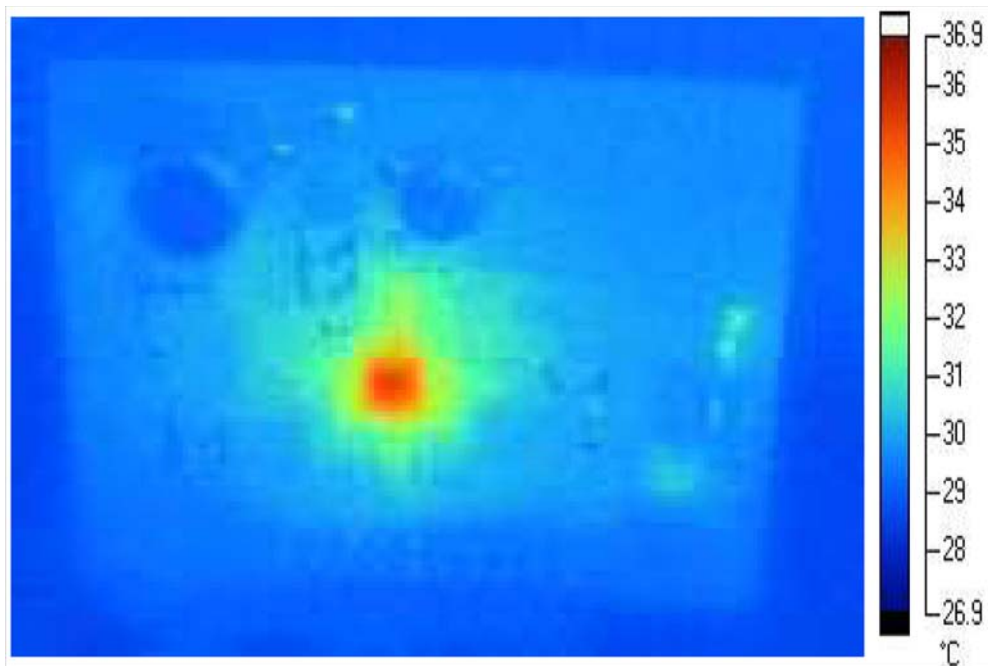

Figure 14. Thermal Snapshot In the Standby Mode

The thermal snapshot of this board for thermally stabilized state is in [Figure 15](#). The ambient temperature was about 29 °C. They were shot under normal cooling conditions — the board was in a vertical position without any fan used. The working point was characterized by half load.

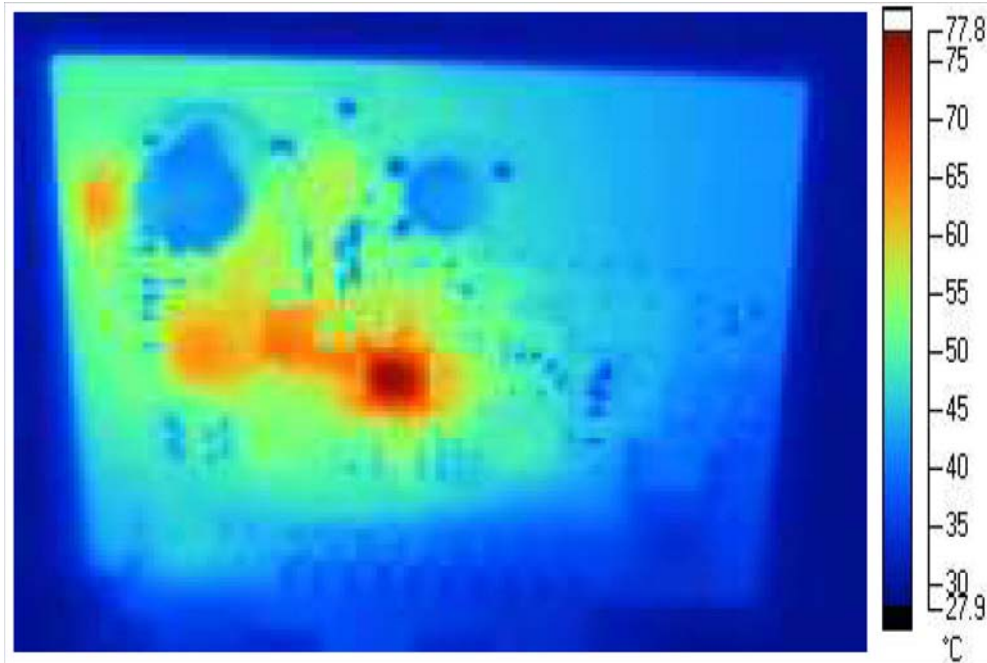

Figure 15. Thermal Snapshot for Half Load

As you can see in [Figure 14](#), the most important components are the MC34700, the D2 diode, the L2 inductor, and the D1 diode. The actually used diode is the STPS340, suggested device for improvement is the STPS3L40UF. The D1 diode is a 1 A Schottky type, suggestion is to use a 2 A type, or even better the same as the D2 (very low forward voltage). It can be also omitted in the final application. The last improvement is changing the L2 inductor for a type with a lower DC internal resistance and higher working current. The DC resistance needs to be lower than 40 m Ω and working current higher than 4 A. These changes can improve the overall efficiency significantly.

9.2 Conclusion

This design was made as an example of the customer application. It can be used together with a standard main transformer with a 12 V AC output voltage, followed by a diode bridge and filtering electrolyte capacitor. Whole power supply can be activated by a standard standby push-button or by a remote-control unit. In this example the RC-5 coding is used. The whole power supply can be deactivated by pressing the standby button, by means of the remote-control unit, and through the IIC bus from the main MCU of the application. The final output levels can be changed in accordance to the final customer application. Inside the MC9S08SG8 MCU is a code example to support this application. The whole code is available on Freescale web site www.freescale.com as AN3592SW2.zip file.



THIS PAGE IS INTENTIONALLY BLANK

How to Reach Us:

Home Page:

www.freescale.com

Web Support:

<http://www.freescale.com/support>

USA/Europe or Locations Not Listed:

Freescale Semiconductor, Inc.
Technical Information Center, EL516
2100 East Elliot Road
Tempe, Arizona 85284
+1-800-521-6274 or +1-480-768-2130
www.freescale.com/support

Europe, Middle East, and Africa:

Freescale Halbleiter Deutschland GmbH
Technical Information Center
Schatzbogen 7
81829 Muenchen, Germany
+44 1296 380 456 (English)
+46 8 52200080 (English)
+49 89 92103 559 (German)
+33 1 69 35 48 48 (French)
www.freescale.com/support

Japan:

Freescale Semiconductor Japan Ltd.
Headquarters
ARCO Tower 15F
1-8-1, Shimo-Meguro, Meguro-ku,
Tokyo 153-0064
Japan
0120 191014 or +81 3 5437 9125
support.japan@freescale.com

Asia/Pacific:

Freescale Semiconductor China Ltd.
Exchange Building 23F
No. 118 Jianguo Road
Chaoyang District
Beijing 100022
China
+86 10 5879 8000
support.asia@freescale.com

For Literature Requests Only:

Freescale Semiconductor Literature Distribution Center
P.O. Box 5405
Denver, Colorado 80217
1-800-441-2447 or 303-675-2140
Fax: 303-675-2150
LDCForFreescaleSemiconductor@hibbertgroup.com

Document Number: AN3592

Rev. 1

10/2008

Information in this document is provided solely to enable system and software implementers to use Freescale Semiconductor products. There are no express or implied copyright licenses granted hereunder to design or fabricate any integrated circuits or integrated circuits based on the information in this document.

Freescale Semiconductor reserves the right to make changes without further notice to any products herein. Freescale Semiconductor makes no warranty, representation or guarantee regarding the suitability of its products for any particular purpose, nor does Freescale Semiconductor assume any liability arising out of the application or use of any product or circuit, and specifically disclaims any and all liability, including without limitation consequential or incidental damages. "Typical" parameters that may be provided in Freescale Semiconductor data sheets and/or specifications can and do vary in different applications and actual performance may vary over time. All operating parameters, including "Typicals", must be validated for each customer application by customer's technical experts. Freescale Semiconductor does not convey any license under its patent rights nor the rights of others. Freescale Semiconductor products are not designed, intended, or authorized for use as components in systems intended for surgical implant into the body, or other applications intended to support or sustain life, or for any other application in which the failure of the Freescale Semiconductor product could create a situation where personal injury or death may occur. Should Buyer purchase or use Freescale Semiconductor products for any such unintended or unauthorized application, Buyer shall indemnify and hold Freescale Semiconductor and its officers, employees, subsidiaries, affiliates, and distributors harmless against all claims, costs, damages, and expenses, and reasonable attorney fees arising out of, directly or indirectly, any claim of personal injury or death associated with such unintended or unauthorized use, even if such claim alleges that Freescale Semiconductor was negligent regarding the design or manufacture of the part.

RoHS-compliant and/or Pb-free versions of Freescale products have the functionality and electrical characteristics as their non-RoHS-compliant and/or non-Pb-free counterparts. For further information, see <http://www.freescale.com> or contact your Freescale sales representative.

For information on Freescale's Environmental Products program, go to

<http://www.freescale.com/epp>.

Freescale™ and the Freescale logo are trademarks of Freescale Semiconductor, Inc. All other product or service names are the property of their respective owners.
© Freescale Semiconductor, Inc. 2008. All rights reserved.

