

The MC34671, MC34673 and MC34675

Industry's most flexible battery charger solution

Applications

- Any Li-ion or Li-polymer battery powered, handheld, portable applications
- Bluetooth® headsets
- Cell phones
- GPS
- MP3 players
- PDAs
- Portable media players

Overview

Battery-powered portable electronic devices need to be recharged for continued use and portability. Freescale's battery charger integrated circuits (ICs) family offers significant advantages and flexibility in battery charging applications. Factory-programmable parameters (see back) allow customers to choose desired specifications such as pin-out, feature set and charging parameters. The IC is then customized by Freescale via a digital interface before shipping.

The MC34671, MC34673 and MC34675 are single input autonomous battery charger ICs capable of delivering up to 1.2A of charge current to a single-cell Li-ion or Li-polymer batteries.

MC34671, MC34673 and MC34675 Single Input Charger Internal Block Diagram

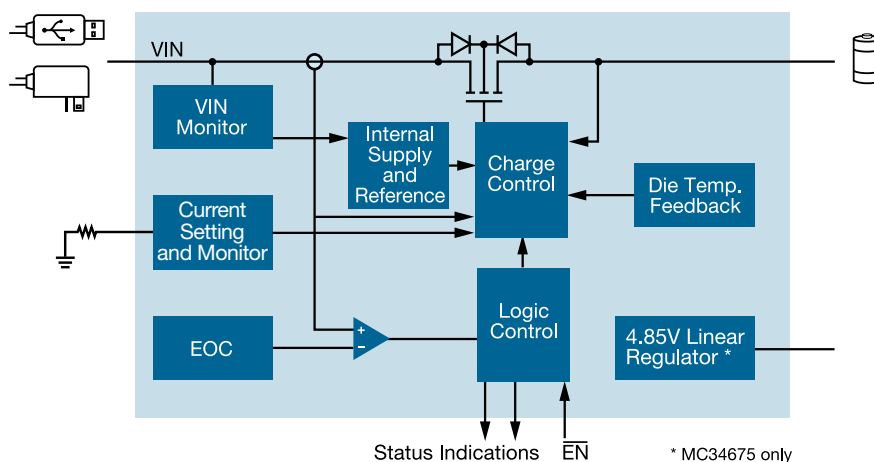

The battery charger input voltage can come from an AC adapter or a USB port power source. The high input voltage, up to 28V, eliminates the need for the external input overvoltage protection circuit required in handheld devices.

Important features of the The MC34671, MC34673 and MC34675 battery charger ICs include a 28V input with overvoltage

protection, overcurrent protection and thermal fold back with up to +/-0.7% voltage accuracy, helping increase battery lifetime and enabling full charge. Freescale's battery charger ICs are rich in features and are extremely flexible to meet the needs of a wide variety of applications. All functions fit into a compact 8-lead 2 mm x 3 mm x 0.65 mm ultra thin dual flat no-lead (UDFN) thermally enhanced package.

Features

- +/-0.7% voltage accuracy over -20°C to +70°C
- 28V maximum input voltage rating (11V OVP for MC34671 and 6.8V for MC34673 and MC34675)
- Capable of delivering up to 1.2A of programmable charge current
- External FETs, blocking diodes and current sense resistors are not required
- Trickle charge for fully discharged batteries
- Low-profile, compact 2 mm x 3 mm x 0.65 mm UDFN thermally enhanced package

Factory-Programmable Parameters for Increased Device Flexibility

- Output voltage
- Input overvoltage protection
- CC current
- Trickle charge current
- Trickle charge voltage threshold
- EOC current
- Recharge threshold
- Thermal fold back threshold
- Timeout
- Verification filter timing

Benefits

- Industry's most flexible Li-ion and Li-polymer battery charger solution
- Complete charger for single-cell Li-ion and Li-polymer batteries
- Feature-rich and easily modified to meet the needs of a wide variety of applications
- +/-0.7% output voltage accuracy over -20°C to +70°C (+/-0.4% at room temperature)
- +/-0.7% output voltage accuracy over -40°C to +85°C (MC34675)
- +/-5% charge current accuracy over -40°C to +85°C (+/-6% for MC34673 and MC34675)
- Factory-configurable parameters for faster time to market and lower system cost
- Meets AC/DC adapter standard YD/T 1591-2006 in the Chinese cell phone market
- Low external component count

Parametric Table

Part Number	Max Input Voltage	Output Current	Temperature Range	Package
MC34671xEP	28V	Up to 600 mA	-40°C to +85°C	2 x 3 UDFN
MC34673xEP	28V	Up to 1.2A	-40°C to +85°C	2 x 3 UDFN
MC34675xEP	28V	Up to 1A	-40°C to +85°C	2 x 3 UDFN

Development Tools

Part Number	Description
KIT34671EPEVBE	Evaluation board to demonstrate the key features of MC34671
KIT34673EPEVBE	Evaluation board to demonstrate the key features of MC34673
KIT34675EPEVBE	Evaluation board to demonstrate the key features of MC34675

Documentation

Freescale Document Number	Title	Description
MC34671	Data Sheet	Presents the specifications for this product
MC34673	Data Sheet	Presents the specifications for this product
MC34675	Data Sheet	Presents the specifications for this product
SG1002	Selector Guide	Analog and power management device comparison

Freescale Semiconductor is a leading provider for over 25 years of high-performance products that use SMARTMOS™ technology that combines digital, power and standard analog functions. The company supplies analog and power management ICs for the automotive, consumer, networking and industrial markets. Freescale's analog and power ICs complement our broad portfolio of microcontrollers, microprocessors, ZigBee® technology, digital signal processors, sensors and development tools. Freescale offers superior support for system solutions to help customers.

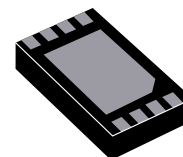

8-pin UDFN

EP SUFFIX (PB-FREE)
98ASA10774D
2 x 3 x 0.65 mm

Learn More:

For more information about Freescale products, please visit www.freescale.com/powermanagement.