

DC-DC Converter Specification(DRAFT)

MPDTH12020WA*

1. Application

This specification applies to DC-DC Converter for telecommunication / data-communication equipment, MPDTH12020WAS/WAH.

For any other application, please contact us before using this product.

2. Customer Reference

Customer Spec. Number
Customer Part Number

3. Murata Part Number

MPDTH12020WAS / MPDTH12020WAH

4. Appearance, Dimensions

[WAS]

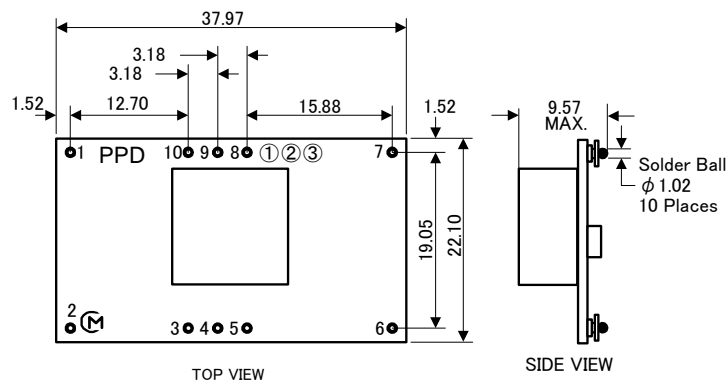



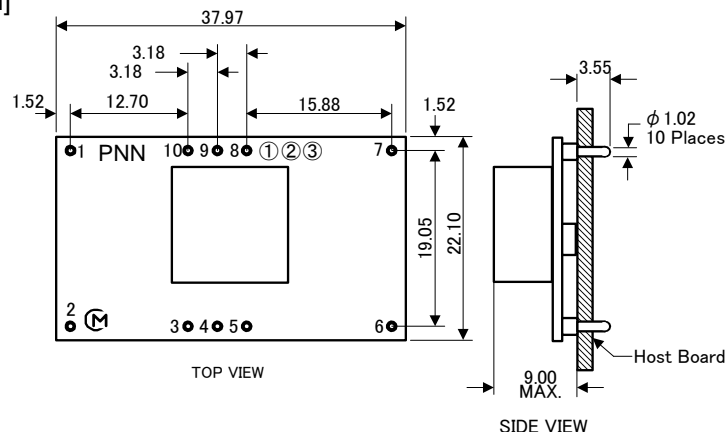

[WAH]



[unit : mm] Tolerance : 0.25mm

⚠ Note:

- This datasheet is downloaded from the website of Murata Manufacturing co., ltd. Therefore, it's specifications are subject to change or our products in it may be discontinued without advance notice. Please check with our sales representatives or product engineers before ordering.
- This datasheet has only typical specifications because there is no space for detailed specifications. Therefore, please approve our product specifications or transact the approval sheet for product specifications before ordering.

- Marking
- (1) MFG ID 
- (2) Parts No. PPD (designates "WAS" P/N series/ SMD packaging)
PNN (designates "WAH" P/N series/ TH packaging)
- (3) Lot No. 
-  Production factory Mark
-  Production Year
-  Production Month (1,2,3,...9,O,N,D)

5. Pin Number and Function

Pin No.	Symbol	Function
1	GND	GND
2	Vin	Input
3	Inhibit	Remote ON/OFF
4	VoAdjust	Vout control
5	VoSense	Vout sense
6	Vout	Output
7	GND	GND
8	Track	Tracking signal input
9	Margin Down	Margin down signal input
10	Margin Up	Margin up signal input

6. Block Diagram

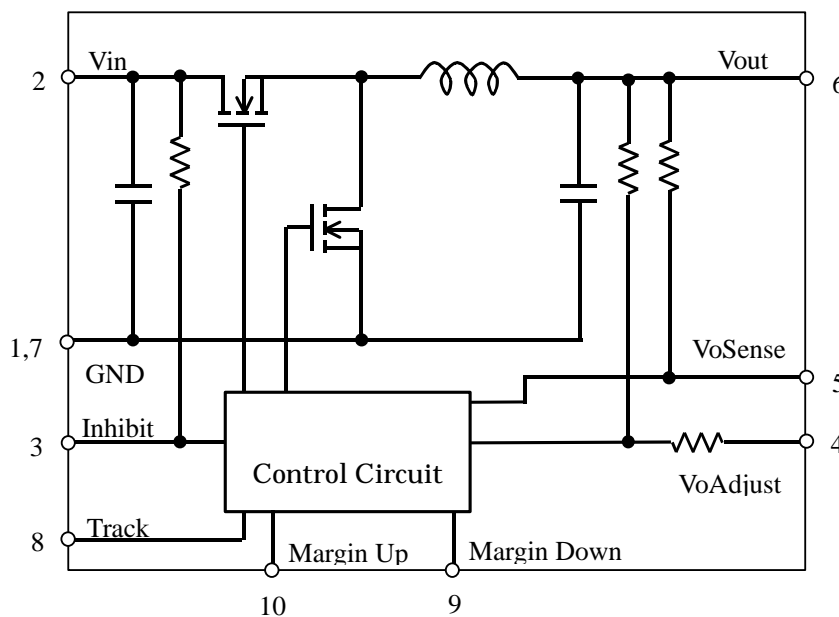

7. Ambient Condition

- 7.1 Operating Temperature Range -40 to +85 °C
- 7.2 Storage Temperature Range -40 to +125 °C

8. Absolute Rating

- 8.1 Track Pin Input Voltage Range -0.3V to Vin+0.3V

⚠ Note:

- This datasheet is downloaded from the website of Murata Manufacturing co., ltd. Therefore, it's specifications are subject to change or our products in it may be discontinued without advance notice. Please check with our sales representatives or product engineers before ordering.
- This datasheet has only typical specifications because there is no space for detailed specifications. Therefore, please approve our product specifications or transact the approval sheet for product specifications before ordering.

9. Characteristics

9.1 Electrical Characteristics (Ta=25 °C)

Unless otherwise stated,

Ta=25 °C, Vin=12V, Vo=3.3V, Cin=560μF, Co=0μF, Io=Iomax

Item	Symbol	Condition	Value			Unit	
			Min.	Typ.	Max.		
Output Current	Io	60°C, 200 LFM Airflow 25°C, Natural Convection	0	-	18(*1)	A	
Input Voltage Range	Vin	Over Io Range	10.8	-	13.2	V	
Set-Point Voltage	Vo tol		-	-	±2(*2)	%Vo	
Temperature Variation	Δ Regtemp	-40°C ≤ Ta ≤ 85°C	-	±0.5	-	%Vo	
Line Regulation	Δ Regline	Over Vin Range	-	±5	-	mV	
Load Regulation	Δ Regload	Over Io Range	-	±5	-	mV	
Total Output Variation	Δ Regtot	Includes set-point, line, load, -40°C ≤ Ta ≤ 85°C	-	-	±3(*2)	%Vo	
Efficiency	η	Io=12A	Rset=280 Ω Vo=5.0V	-	95	-	%
			Rset=2.0k Ω Vo=3.3V	-	93	-	
			Rset=4.32k Ω Vo=2.5V	-	92	-	
			Rset=11.5k Ω Vo=1.8V	-	90	-	
			Rset=24.3k Ω Vo=1.5V	-	88	-	
			Rset=open Vo=1.2V	-	86	-	
Ripple Voltage	Vr	BW=20MHz Co=10μF(Ceramic)	Vo ≤ 2.5V	-	32(*3)	-	mVpp
			Vo > 2.5V	-	1(*3)	-	%Vo
Short Circuit Protection	Io trip	Reset, Followed by Auto-Recovery		-	30	-	A
Transient Response	ttr	1A/μs load step, 50 to 100% Iomax, Co=330μF	Recovery Time	-	70	-	μsec
	Δ Vtr		Vo Deviation	-	70	-	mV
Margin Up/Down Adjust	Δ Vomargin			-	±5	-	%
Margin Input Current	IIL margin	Pin to GND		-	-8	-	μA
Track Input Current	IIL track	Pin to GND		-	-	-130 (*4)	μA
Track Slew Rate	dVtrack/dt	Cout ≤ Cout(max)		-	-	1	V/ms
Rising UVLO Threshold	UVLOr	Vin=Increasing		-	9.7	10.4	V
Falling UVLO Threshold	UVLOf	Vin=Decreasing		8.1	9.2	-	V

⚠ Note:

1. This datasheet is downloaded from the website of Murata Manufacturing co., ltd. Therefore, it's specifications are subject to change or our products in it may be discontinued without advance notice. Please check with our sales representatives or product engineers before ordering.
2. This datasheet has only typical specifications because there is no space for detailed specifications. Therefore, please approve our product specifications or transact the approval sheet for product specifications before ordering.

Item	Symbol	Condition	Value			Unit
			Min.	Typ.	Max.	
Inhibit Control	VIH	Referenced to GND	This pin should be left open for operation (*4)			V
Inhibit Control	VIL	Referenced to GND	-0.2	-	0.5	V
Inhibit Control	IIL inhibit	Pin to GND	-	-240	-	μ A
Inhibit Control	Iin inh	Inhibit to GND, Track open	-	5	-	mA
Switching Frequency	Frq	Over Vin and Io Ranges	-	320	-	kHz
External Input Capacitor	Cin		560 (*5)	-	-	μ F
External Output Capacitor	Cout	Non-Ceramic ($ESR \geq 4m\Omega$)	0	330 (*6)	9900	μ F
		Ceramic	0	-	300	
MTBF	MTBF	Per Bellcore TR-332, 50% stress, Ta=40°C, ground benign	5.3	-	-	10 ⁶ Hrs

(*1) See SOA curves or consult factory for appropriate derating.

(*2) The set-point voltage tolerance is affected by the tolerance and stability of Rset. The stated limit is unconditionally met if Rset has a tolerance of +/-1% with 100ppm/°C or better temperature stability.

(*3) The peak-to-peak output ripple voltage is measured with an external 10 μ F ceramic capacitor.

(*4) This control pin has an internal pull-up. If it is left open-circuit the module will operate when input power is applied.

(*5) The external input capacitor must have a ripple current rating at or above 800mA rms.

(*6) An external output capacitor is not required for basic operation. Adding 330 μ F of distributed capacitance at the load however will improve transient response.

9.2 Safe Operating Area (SOA)

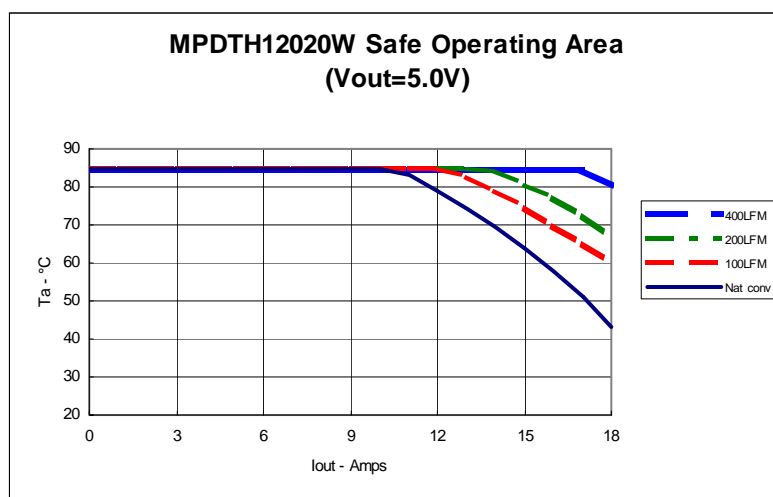

The above SOA represents the condition at which internal components are at or below the manufacturer's maximum operating temperatures. Derating limits apply to modules soldered directly to a 4 in.x4in. 4-layer PCB with 1 oz. copper. For more reliable operation, appropriate derating is desirable.

⚠ Note:

1. This datasheet is downloaded from the website of Murata Manufacturing co., ltd. Therefore, it's specifications are subject to change or our products in it may be discontinued without advance notice. Please check with our sales representatives or product engineers before ordering.
2. This datasheet has only typical specifications because there is no space for detailed specifications. Therefore, please approve our product specifications or transact the approval sheet for product specifications before ordering.

10. Adjusting the Output Voltage

The output voltage may be adjusted from 1.2V to 5.5V by inserting resistance between Vo Adjust-pin (pin 4) and GND-pin (pins 1, 7). The resistor's tolerance should be +/-1%, with 100ppm/°C (or better).

The following equation gives the required external-resistance value to adjust the output voltage to the required Vout.

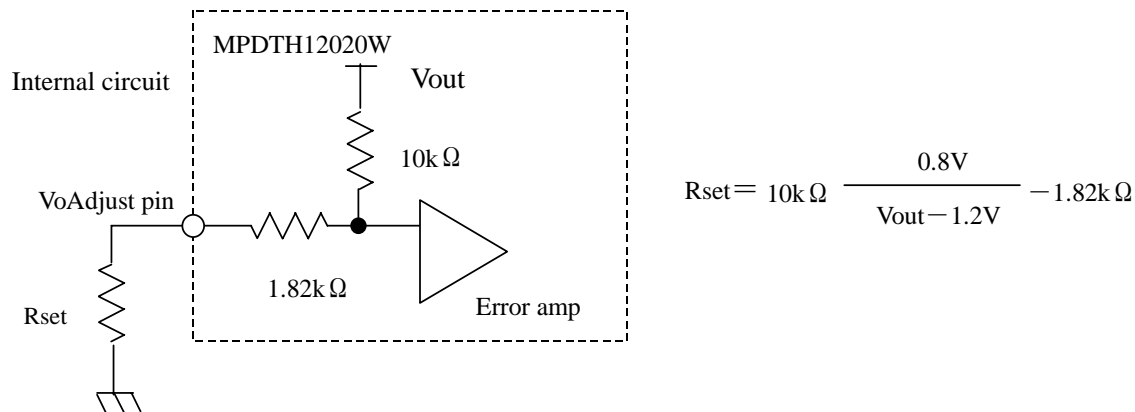

< Rset Calculation Example >

Vout [V]	Calculated Rset[kΩ]	Rset example
5	0.29	270Ω + 20Ω
3.3	1.99	2kΩ
2.5	4.33	4.3kΩ + 30Ω
2.0	8.18	7.5kΩ + 680Ω
1.8	11.51	11kΩ + 510Ω
1.5	24.85	24kΩ + 820Ω
1.2	∞	Open

11. Test Circuit

Utilizing the following test circuit, the initial values specified in section 9 should be met.

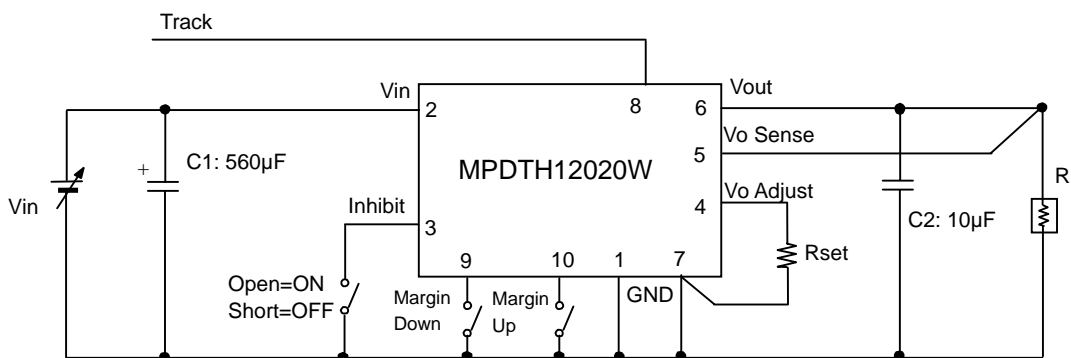

C1 : 560μF / 25V (Aluminum Electrolytic Capacitor)
 C2 : 10μF / 6.3V (Ceramic Capacitor)

⚠ Note:

1. This datasheet is downloaded from the website of Murata Manufacturing co., ltd. Therefore, it's specifications are subject to change or our products in it may be discontinued without advance notice. Please check with our sales representatives or product engineers before ordering.
2. This datasheet has only typical specifications because there is no space for detailed specifications. Therefore, please approve our product specifications or transact the approval sheet for product specifications before ordering.

Ripple Noise Measurement Circuit

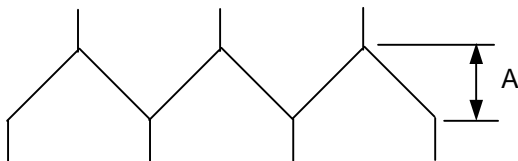
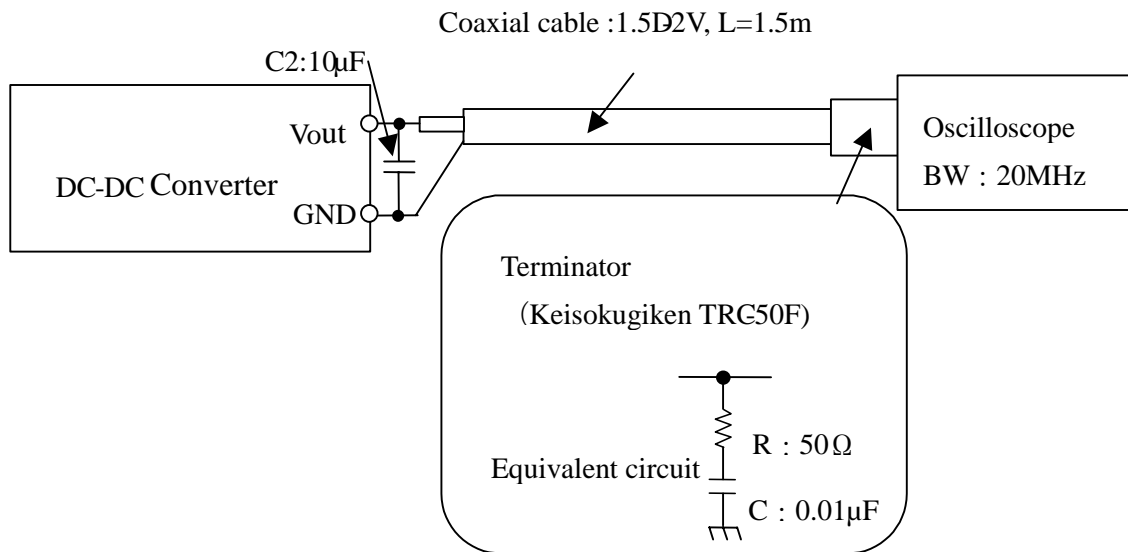

A : Output Ripple Voltage

⚠ **Note:**

1. This datasheet is downloaded from the website of Murata Manufacturing co., ltd. Therefore, it's specifications are subject to change or our products in it may be discontinued without advance notice. Please check with our sales representatives or product engineers before ordering.
2. This datasheet has only typical specifications because there is no space for detailed specifications. Therefore, please approve our product specifications or transact the approval sheet for product specifications before ordering.

12 . Packaging Information

12. 1 Tray Dimensions

DC-DC Converter devices are placed on the trays. (See Fig.1)

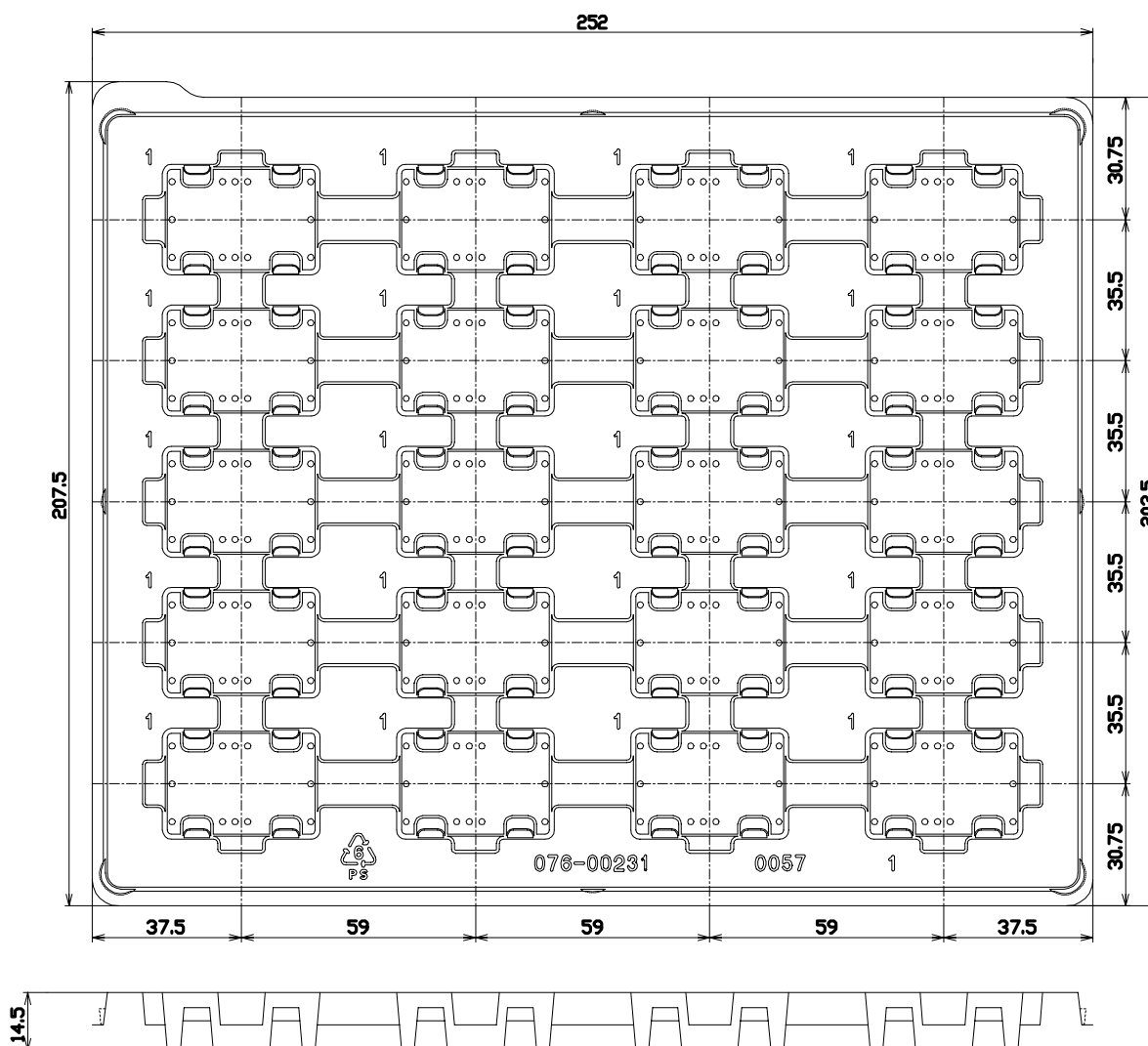

Fig.1

12. 2 Maximum Devices per Tray

20 pcs/tray

⚠ Note:

1. This datasheet is downloaded from the website of Murata Manufacturing co., ltd. Therefore, it's specifications are subject to change or our products in it may be discontinued without advance notice. Please check with our sales representatives or product engineers before ordering.
2. This datasheet has only typical specifications because there is no space for detailed specifications. Therefore, please approve our product specifications or transact the approval sheet for product specifications before ordering.

12. 3 Packaging Form

Trays with devices have lids placed on top and are packed in a corrugated box. (See Fig.2)

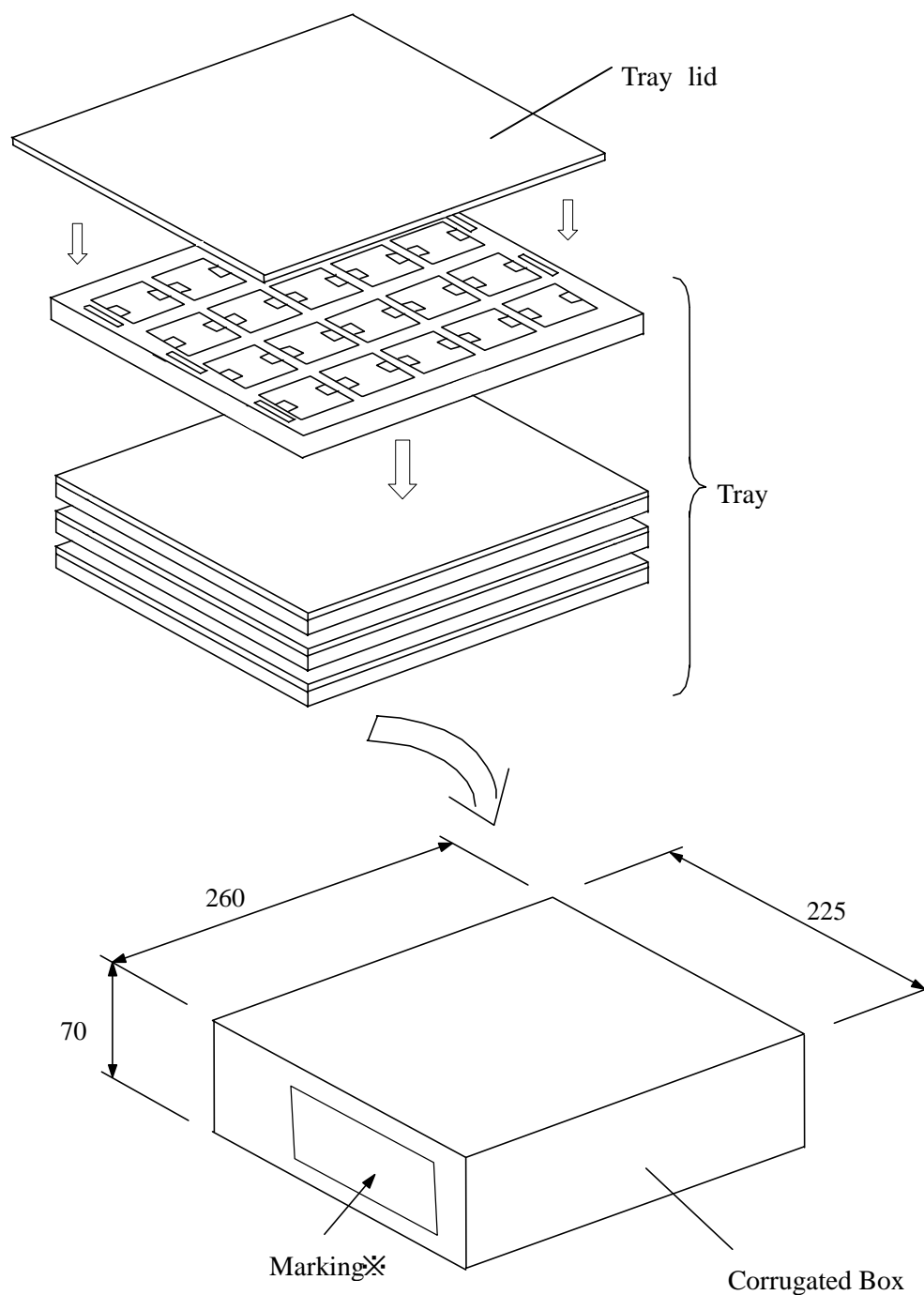

※Marking on the box
 MURATA Parts Number
 Quantity
 Inspection No.

Fig.2

⚠ **Note:**

1. This datasheet is downloaded from the website of Murata Manufacturing co., ltd. Therefore, it's specifications are subject to change or our products in it may be discontinued without advance notice. Please check with our sales representatives or product engineers before ordering.
2. This datasheet has only typical specifications because there is no space for detailed specifications. Therefore, please approve our product specifications or transact the approval sheet for product specifications before ordering.

13. Production factory
 Komatsu Murata Mfg.Co.,Ltd.
 Kanazu Murata Mfg.Co.,Ltd.
 Wakura Murata Mfg.Co.,Ltd.

14.  Note

1. Inrush current protection is not a feature of this device.
2. Correct polarity at the device's input is critical. If connected incorrectly damage of the device may result. We recommend that customers ensure that a diode/ fuse combination is utilized per the following diagram to prevent a reverse polarity condition from occurring.

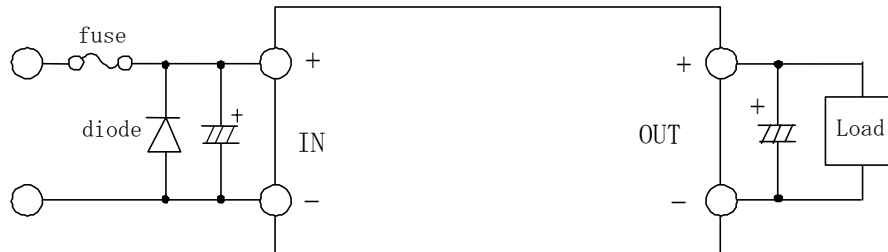

※Please select a diode/ fuse combination after confirming the operation of your product.

3. Limitation of Application

Please contact us before using this product for the applications listed below which require especially high reliability for the prevention of defects, which might directly cause damage to the third party's life, body or property.

- ① Aircraft equipment
- ② Aerospace equipment
- ③ Undersea equipment
- ④ Power plant control equipment
- ⑤ Medical equipment
- ⑥ Transportation equipment (vehicles, trains, ships, etc.)
- ⑦ Traffic signal equipment
- ⑧ Disaster prevention /crime prevention equipment
- ⑨ Any other application of similar complexity and/or reliability requirements to the applications listed above.

15. Notice

15. 1 Soldering

15. 1. 1 Flux

Please solder this product with Rosin Flux which contains of 0.2%wt. or less chlorine.

Please do not use high activity acid flux or water soluble flux as they may reduce the reliability of this device.

 Note:

1. This datasheet is downloaded from the website of Murata Manufacturing co., ltd. Therefore, it's specifications are subject to change or our products in it may be discontinued without advance notice. Please check with our sales representatives or product engineers before ordering.
2. This datasheet has only typical specifications because there is no space for detailed specifications. Therefore, please approve our product specifications or transact the approval sheet for product specifications before ordering.

15.1.2 PCB Land Pattern Recommendation

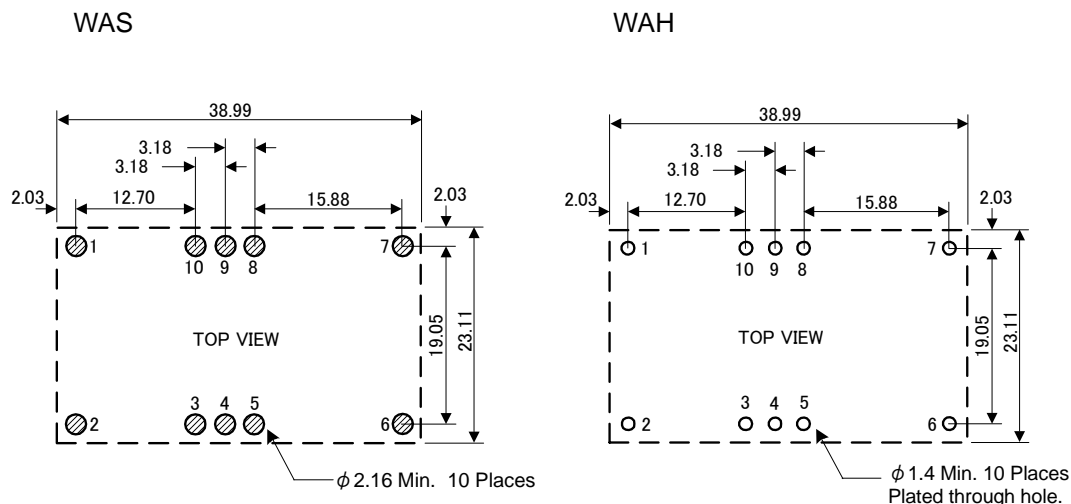

15.1.3 Soldering Conditions Recommendation

This product is RoHS compatible. The following profile is recommended for the reflow of the SMD product (WAS) using Pb-free solder paste (Sn-Ag-Cu).

Method : Full convection reflow soldering

Reflow Soldering Profile
JEDEC IPC/JEDEC J-STD-020C
Table 5-2 Classification Reflow Profile
Pb-Free Assembly Large Body

Profile details	
Soldering temperature	: 245 °C +0/-5 °C
Soldering time	: 20 to 40 seconds, 240 to 245 °C
Heating time	: 60 to 150 seconds, over 217 °C
Preheating time	: 60 to 180 seconds, 150 to 200 °C
Programming rate	: 3 °C / sec. Max., 217 to 245 °C
Descending rate	: 6 °C / sec. Max.
Total soldering time	: 8 minutes Max., 25 to 245 °C
Times	: 1time

- ※ Elimination of any additional vibration applied to this device during reflow is highly recommended.
- Careful regulation of temperature is recommended to avoid the separation of mounted components from this device during reflow.

15.2 Cleaning

Please use no-clean type flux and do not wash this product.

⚠ Note:

1. This datasheet is downloaded from the website of Murata Manufacturing co., ltd. Therefore, it's specifications are subject to change or our products in it may be discontinued without advance notice. Please check with our sales representatives or product engineers before ordering.
2. This datasheet has only typical specifications because there is no space for detailed specifications. Therefore, please approve our product specifications or transact the approval sheet for product specifications before ordering.

15. 3 Storage

15. 3. 1 This product should be treated as MSL2 product when it is reflowed according to recommended soldering conditions described in section 15.1.3. .

This product can be stored for up to 1 year at below 30 °C 60%R.H., without requiring an additional baking process.

If stored for over 1 year, baking of this device before soldering is recommended.

The recommended baking condition of individual devices is 125±5 °C /24hour.

If devices are baked in the manufacturer's tray or in manufacturer's tape, 60±5 °C /168hour is recommended.

Please avoid dampness and heat or locations where temperatures may vary widely to avoid possible water condensation on the device. Exposure to such environments may degrade the performance and/ or the reliability of the device.

If the device must be stored for a longer time than 1 year it is recommend that solderability be tested regularly to confirm material degradation has not occurred.

15. 3. 2 Murata recommends that this device not be stored under conditions such as:

a location where surfaces have an accumulation of dust, direct exposure to ocean air, or in an atmosphere containing a corrosive gas (e.g., Cl₂, NH₃, SO₂, NO_X, etc.).

15. 4 Operational Environment and Operational Conditions

15. 4. 1 Operational Environment

This device is not water-, chemical- or corrosion-proof.

In order to prevent leakage of electricity and abnormal temperature rise of the device, do not operate under the following environmental conditions:

- (1) An atmosphere containing corrosive gas (Cl₂, NH₃, SO₂, NO_X, and so on)
- (2) A high-dust environment
- (3) Under the exposure of direct sunlight
- (4) A location where the likelihood of exposure to water or water condensation exists.
- (5) A location exposed to ocean air
- (6) Any locations similar to the above

15. 4. 2 Operational Conditions

Please use this product within specified values (power supply, temperature, input, output and load condition, and so on). If the device is exposed to conditions outside of the specified values reliability of the device may be adversely affected.

15. 4. 3 Note prior to use

Exposure of this device to a high-level static charge, over-rated voltage, or reverse voltage may result in diminished reliability and/ or failure. Murata recommends that the following conditions be avoided prior to use of this device:

- (1) Supply of power outside of rated value (see section 8), Supply of reverse power or inadequate connection of a 0V (DC) line
- (2) Electrostatic discharge from production line and/or operator
- (3) Electrification of the device from electrostatic induction

In addition Murata recommends that excessive mechanical shock be avoided.

15. 5 Transportation

Murata recommends that when transporting this product, it be packed so as to avoid damage by mechanical vibration or exposure to adverse conditions such as ocean air, high humidity. It is additionally recommended that appropriate instructions and guidelines be communicated to carriers to prevent exposure to these same conditions.

16. Note

1. Murata recommends that customers ensure that the evaluation and testing of these devices are completed with this product actually assembled on their product.
2. All the items and parameters in this product specification have been prescribed on the premise that Murata's product is used for the purpose, under the condition and in the environment mutually agreed upon.

**This document is subject to revision without prior or subsequent notice.
Please contact Murata for latest documentation.**

Note:

1. This datasheet is downloaded from the website of Murata Manufacturing co., ltd. Therefore, it's specifications are subject to change or our products in it may be discontinued without advance notice. Please check with our sales representatives or product engineers before ordering.
2. This datasheet has only typical specifications because there is no space for detailed specifications. Therefore, please approve our product specifications or transact the approval sheet for product specifications before ordering.