

DC-DC Converter Specification

MYSSM3R31ECEN

1. Application

This specification applies to DC-DC Converter for telecommunication / data-communication equipment, MYSSM3R31ECEN.

For any other application, please contact us before using this product.

2. Customer Reference

Customer Spec. Number
Customer Part Number

3. Murata Part Number

MYSSM3R31ECEN

4. Appearance, Dimensions

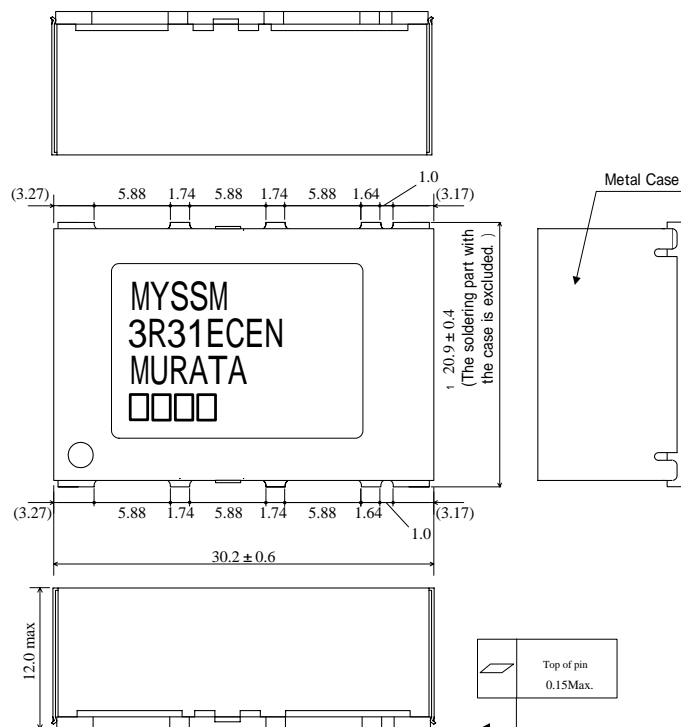

【Unit : mm】

Tolerance ± 0.3 mm

Tolerance is not accumulated.

Marking

- | | |
|------------------------------|---------------|
| 1. Manufacturer Parts Number | MYSSM3R31ECEN |
| 2. Manufacturer ID | MURATA |
| 3. Trace code | □ □ □ □ |
| 4. Pin No.1 Side Marking | ○ |

⚠ Note:

- This datasheet is downloaded from the website of Murata Manufacturing co., ltd. Therefore, it's specifications are subject to change or our products in it may be discontinued without advance notice. Please check with our sales representatives or product engineers before ordering.
- This datasheet has only typical specifications because there is no space for detailed specifications. Therefore, please approve our product specifications or transact the approval sheet for product specifications before ordering.

5. Pin Number and Function

Pin No.	Symbol	Function
1	Vin	Input
2	GND	GND
3	GND	GND
4	N.C.	N.C. (Internally used)
5	ON/OFF	Remote ON/OFF
6	Vout	Output
7	GND	GND
8	GND	GND

6. Block Diagram

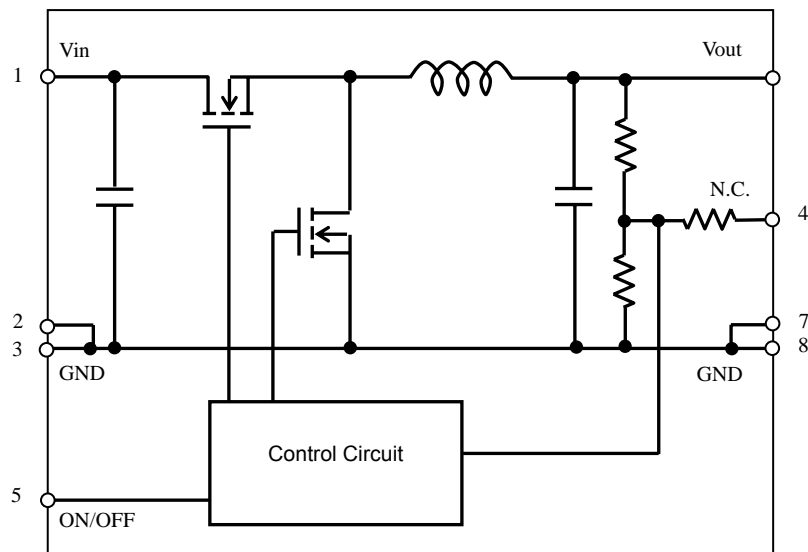

7. Environmental Conditions

7.1 Operating Temperature Range	-40°C ~ +85°C
7.2 Storage Temperature Range	-40°C ~ +85°C
7.3 Operating Humidity Range	20% ~ 85% (No water condenses in any cases.)
7.4 Storage Humidity Range	10% ~ 90% (No water condenses in any cases.)

8. Absolute Maximum Rating

Item	Unit	Absolute Rating	Remarks
Minimum Input Voltage	V	0	
Maximum Input Voltage,	V	30	
Maximum ON/OFF Voltage	V	13.2	

No voltage, no matter how instantaneous, shall be applied beyond the absolute maximum voltage rating to this product. If you apply any voltage over this limit the product characteristics will deteriorate or the product itself will be destroyed. Even though it may continue operating for a while after the over-voltage event, its life will likely be shortened significantly. Reliability and life of the module may degrade similarly if the maximum operating voltage rating is continuously exceeded. This product is designed to operate within the maximum operating voltage rating specification.

⚠ Note:

1. This datasheet is downloaded from the website of Murata Manufacturing co., ltd. Therefore, it's specifications are subject to change or our products in it may be discontinued without advance notice. Please check with our sales representatives or product engineers before ordering.
2. This datasheet has only typical specifications because there is no space for detailed specifications. Therefore, please approve our product specifications or transact the approval sheet for product specifications before ordering.

9. Characteristics

9.1. Electrical Characteristics

9.1.1. Input Characteristics (Ta= 25°C)

Item	Symbol	Condition	Value			Unit
			Min.	Typ.	Max.	
Input Voltage Range	Vin		19.2	24.0	28.8	V

9.1.2. Interface Characteristics (Ta= 25°C)

Item	Symbol	Condition	Value			Unit
			Min.	Typ.	Max.	
ON/OFF pin High Voltage	VIH	Vin=24V, Iout=1.5A	2.5		Vin	V
ON/OFF pin Low Voltage	VIL		0	-	0.5	

9.1.3. General Characteristics (Ta= 25°C)

Item	Symbol	Condition	Value			Unit
			Min.	Typ.	Max.	
Output Voltage	Vout	Vin=19.2~28.8V, I _o =0 ~ 1.5A	3.201	3.30	3.399	V
Output Current	I _{out}	Vin=19.2~28.8V	0	-	1.5	A
Ripple Voltage	V _{rpl}	Vin=24V, I _{out} =1.5A, BW = 20MHz,	-	15	-	mV(pp)
Efficiency	EFF	Vin =24V, I _{out} =1.5A		88	-	%
Protection Output Current	ISCP	Vin=19.2~28.8V	1.6	-	-	A
Short Circuit Protection	SCP	If output is shorted to GND, DC-DC Converter shall be operated in a hiccup mode. After the short circuit event has cleared, the output is automatically brought back into regulation.				

 Caution

The above electrical characteristics are guaranteed with the condition that the impedance of the input voltage source is sufficiently low as shown in section 10. Connecting an input inductance or using an input power supply with output inductance may cause an unstable operation of this device. Please check the proper operation of this device with the peripheral circuits on your system.

9.1.4. Thermal Derating

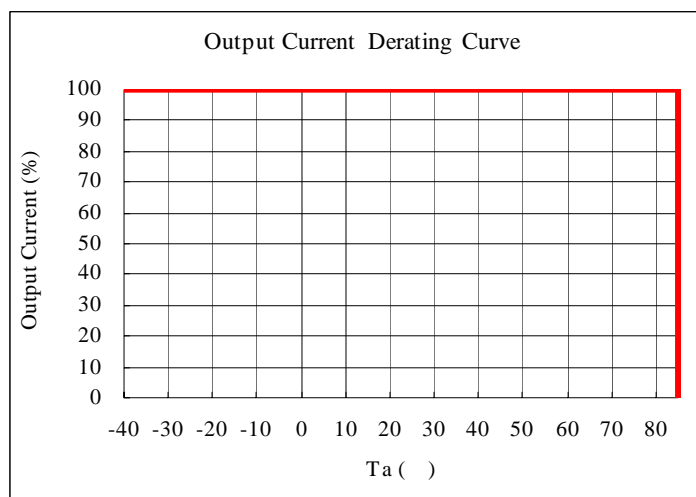
 Note:

- This datasheet is downloaded from the website of Murata Manufacturing co., ltd. Therefore, it's specifications are subject to change or our products in it may be discontinued without advance notice. Please check with our sales representatives or product engineers before ordering.
- This datasheet has only typical specifications because there is no space for detailed specifications. Therefore, please approve our product specifications or transact the approval sheet for product specifications before ordering.

9.2. Operation Information

9.2.1. Parallel Operation.

This product is incapable of parallel operation

9.2.2. ON/OFF Control

ON/OFF function

Using the ON/OFF feature, the operation of this product can be disabled without removal of the input voltage. Sequencing of a power supply system and power-saving control can be easily achieved using this function.

ON/OFF Control Operation

When ON/OFF-pin(5pin) is connected to Vin Output Voltage =OFF
 When ON/OFF-pin(5pin) is connected to GND or open Output Voltage=ON

9.3. Reliability

9.3.1. Humidity

According to JIS-C-0022.

40 ± 2°C, 90 to 95%RH, 100 hours. Leave for 4 hours at room temperature.

No damage in appearance and no deviation from electrical characteristics (section 9.1.).

9.3.2. Temperature Cycles

Repeat cycle 5 times. Leave 2 hours at room temp.

No damage in appearance and no deviation from electrical characteristics (section 9.1.).

Step	Condition	Time
1	-40°C ± 3°C	30 minutes
2	Room Temp.	5-10 minutes
3	+85°C ± 2°C	30 minutes
4	Room Temp.	5-10 minutes

9.3.3. Vibration

10 to 55Hz, 1.5mm amplitude (1minute cycle), 1 hour for each of X, Y, Z directions.

No damage in appearance and no deviation from electrical characteristics (section 9.1.).

9.3.4. Mechanical Shock

20G, 1 time for each X, Y, Z directions.

No damage in appearance and no deviation from electrical characteristics (section 9.1.).

⚠ Note:

1. This datasheet is downloaded from the website of Murata Manufacturing co., ltd. Therefore, it's specifications are subject to change or our products in it may be discontinued without advance notice. Please check with our sales representatives or product engineers before ordering.
2. This datasheet has only typical specifications because there is no space for detailed specifications. Therefore, please approve our product specifications or transact the approval sheet for product specifications before ordering.

10. Test Circuit

In the following test circuit, the initial values under item 9.1.. should be met.

10.1. General Measure Circuit

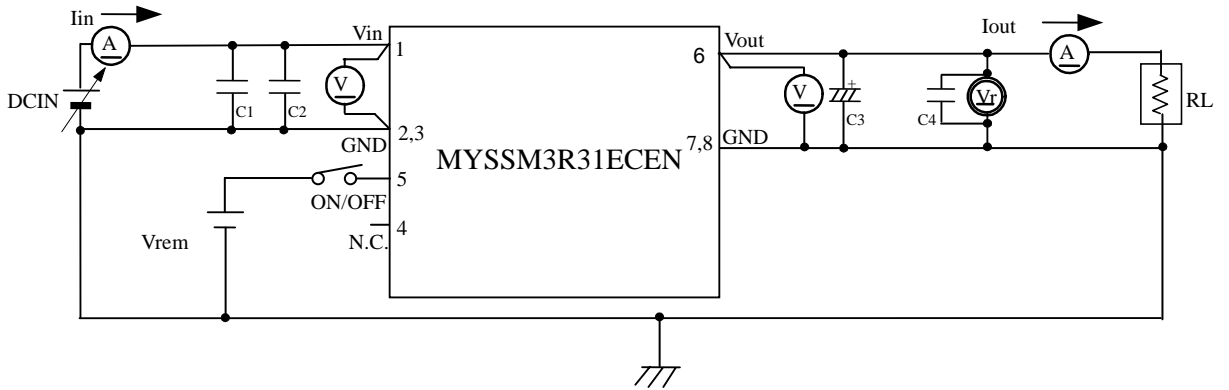

- C1,C2 : 4.7 μ F/50V Ceramic Capacitor
- C3 : 100 μ F/6.3V Conductive Polymer Aluminum Capacitor
(APXA6R3ARA101MF55G :Nippon Chemi-con)
- C4 : 0.1 μ F Ceramic Capacitor

Please make sure to place C1,C2 and C3 nearby input and output terminal of DC-DC converter.

10.2. Ripple Noise Measurement Circuit

Coaxial cable : 1.5D-2V, L=1.5m

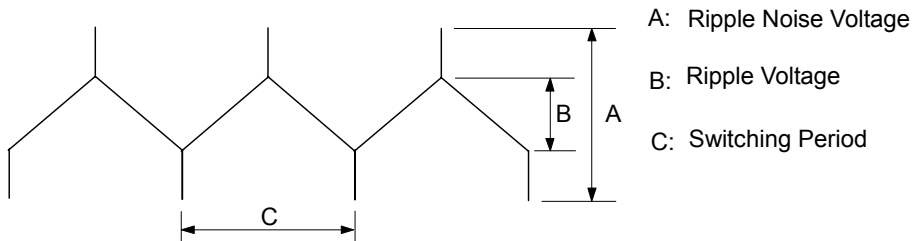
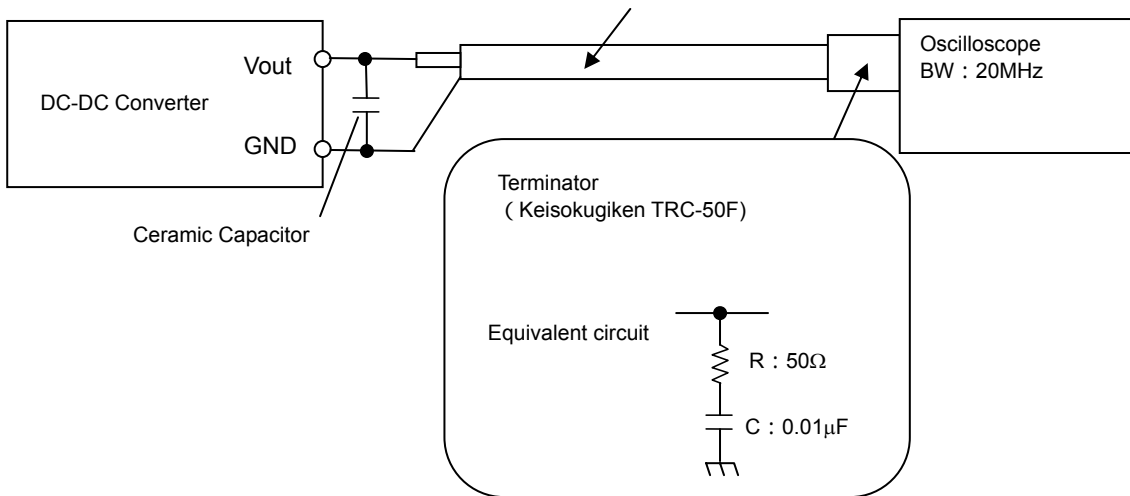

Note:

1. This datasheet is downloaded from the website of Murata Manufacturing co., ltd. Therefore, it's specifications are subject to change or our products in it may be discontinued without advance notice. Please check with our sales representatives or product engineers before ordering.
2. This datasheet has only typical specifications because there is no space for detailed specifications. Therefore, please approve our product specifications or transact the approval sheet for product specifications before ordering.

11. Packaging Specification

11.1. Packing Form

These are packed in a tray(See Fig.11-1)

11.2. The number of products in pack specification form.

32pcs./tray

If the products have fraction, may not follow this specification.

11.3.Packaging Form

These trays packed products are packaging in a corrugated box alternately.

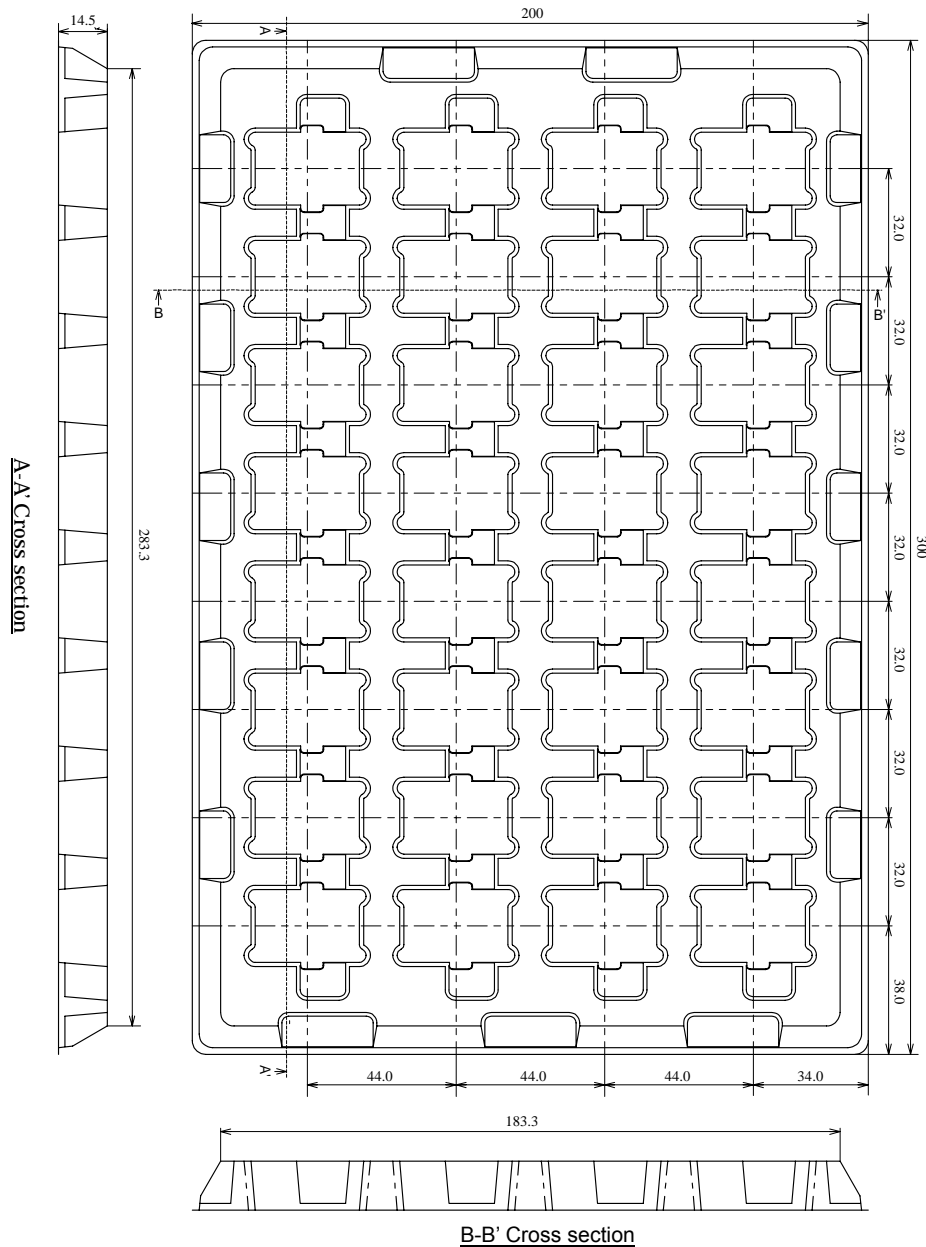

Fig.11-1

⚠ Note:

1. This datasheet is downloaded from the website of Murata Manufacturing co., ltd. Therefore, it's specifications are subject to change or our products in it may be discontinued without advance notice. Please check with our sales representatives or product engineers before ordering.
2. This datasheet has only typical specifications because there is no space for detailed specifications. Therefore, please approve our product specifications or transact the approval sheet for product specifications before ordering.

12. Production factory

Komatsu Murata Mfg.Co., Ltd.
 Kanazu Murata Mfg. Co., Ltd.
 Wakura Murata Mfg. Co., Ltd.

13.  Caution

1. Be sure to provide an appropriate fail-safe function on your product to prevent secondary damage that may be caused due to abnormal functional or failure of this product.
2. Inrush current protection is not a feature of this product.
3. Please connect the input terminals with the correct polarity. If an error in polarity connection is made this product may be damaged. If this product is damaged internally, an elevated input current may flow, and so this product may exhibit an abnormal temperature rise, or your product may be damaged. Please add a diode and fuse per the following diagram to protect them.

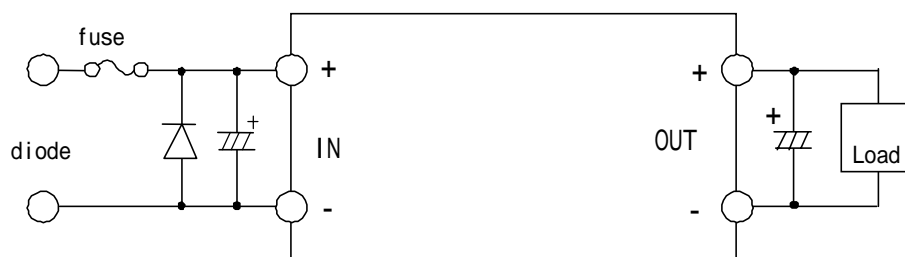

Please select diode and fuse after confirming the operation of your product.

4. Limitation of Application

Please contact us before using this product for the applications listed below which require especially high reliability for the prevention of defects, which might directly cause damage to the third party's life, body or property.

Aircraft equipment
 Aerospace equipment
 Undersea equipment
 Power plant control equipment
 Medical equipment
 Transportation equipment (vehicles, trains, ships, etc.)
 Traffic signal equipment
 Disaster prevention /crime prevention equipment
 Any other application of similar complexity and/or reliability requirements to the applications listed above.

14. Notice

14.1. Soldering

14.1.1. Flux

Please solder this product with Rosin Flux that contains of 0.2wt% or less chlorine.
 Please do not use high activity acid flux or water-soluble flux as they may reduce the reliability of this product.

 **Note:**

1. This datasheet is downloaded from the website of Murata Manufacturing co., ltd. Therefore, it's specifications are subject to change or our products in it may be discontinued without advance notice. Please check with our sales representatives or product engineers before ordering.
2. This datasheet has only typical specifications because there is no space for detailed specifications. Therefore, please approve our product specifications or transact the approval sheet for product specifications before ordering.

14.1.2. PCB Land Pattern Recommendation

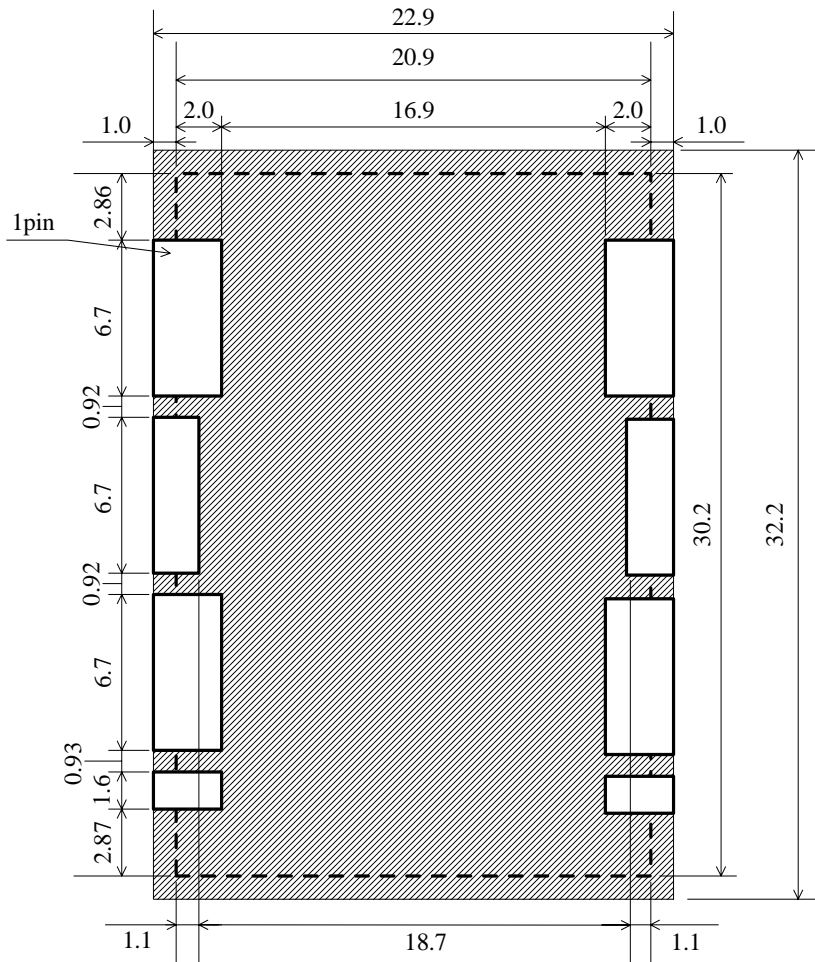

In the above-mentioned chain line area  wirings other than land are assumed to be a prohibition.

There are wiring coppers or through-hole via at the bottom side of the DC-DC converter. When you design your PCBs, please be careful not to short the circuit of the DC-DC converter or PCBs.

Note:

1. This datasheet is downloaded from the website of Murata Manufacturing co., ltd. Therefore, it's specifications are subject to change or our products in it may be discontinued without advance notice. Please check with our sales representatives or product engineers before ordering.
2. This datasheet has only typical specifications because there is no space for detailed specifications. Therefore, please approve our product specifications or transact the approval sheet for product specifications before ordering.

14.1.3. Soldering Conditions Recommendation

Reflow Soldering

This product is RoHS compliant. The following profile is recommended for the reflow of this product using Pb-free solder paste (Sn-Ag-Cu).

Method : Full convection reflow soldering

Reflow Soldering Profile

JEDEC IPC/JEDEC J-STD-020D

Table 5-2 Classification Reflow Profile

Pb-Free Assembly Large Body

Profile details

Soldering temperature : 245°C+0/-5°C
 Soldering time : 30 seconds, 240 to 245°C
 Heating time : 60 to 150 seconds, over 217°C
 Preheating time : 60 to 120 seconds, 150 to 200°C
 Programming rate : 3°C/ sec. Max., 217 to 245°C
 Descending rate : 6°C/ sec. Max.
 Total soldering time : 8 minutes Max., 25 to 245°C
 Times : 1 time

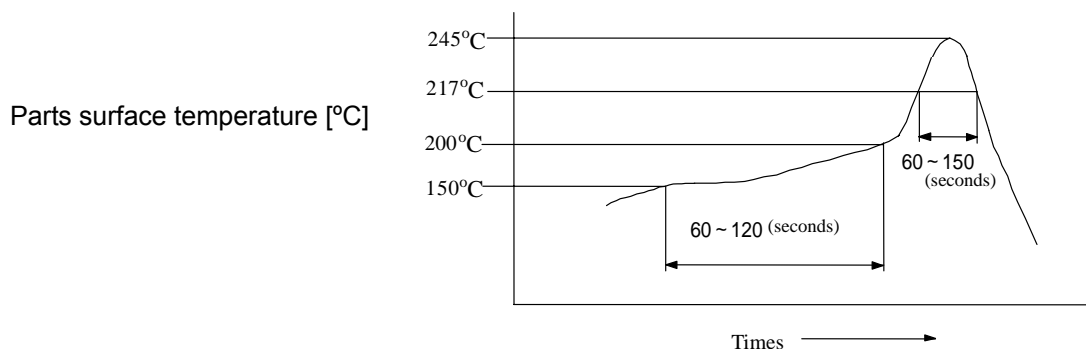

Do not vibrate for the products on reflow.

Please need to take care temperature control because mounted parts may come off if the product are left under the high temperature.

Do not reflow DC-DC converter as follows, because DC-DC converter may fall down from a substrate during reflowing.

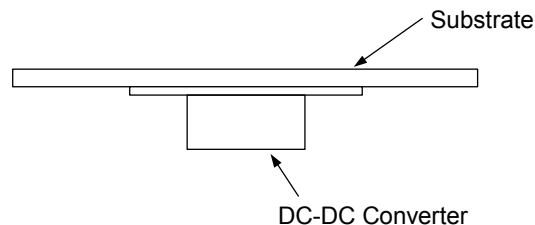

⚠ Note:

1. This datasheet is downloaded from the website of Murata Manufacturing co., ltd. Therefore, it's specifications are subject to change or our products in it may be discontinued without advance notice. Please check with our sales representatives or product engineers before ordering.
2. This datasheet has only typical specifications because there is no space for detailed specifications. Therefore, please approve our product specifications or transact the approval sheet for product specifications before ordering.

14. 2. Cleaning

Please use no-cleaning type flux and do not wash this product.

14.3. Storage

14.3.1. Please store the products in room where the temperature/humidity is stable and direct sunlight cannot come in, and use the products within 6 months after delivery.

Please avoid damp and heat or such places where the temperature greatly changes, as water may condense on this product, and the quality of characteristics may be reduced, and/or be the solderability may be degraded.

If this product needs to be stored for a long time (more than 1 year), this product may be degraded in solderability and/or corroded. Please test the solderability of this product regularly.

Baking before reflow process is unnecessary to store the products under 30 ± 5 °C, 60%RH or less up to 6 months.

In case the storage condition is over above mentioned, if these are unpacked condition, please bake them at 125 ± 5 °C /24hour. If these are packed in a tape, please bake them before soldering at 60 ± 5 °C /168hour.

14.3.2. Please do not store this product in places such as :

A dusty place, a place exposed directly to sea breeze, or in an atmosphere containing corrosive gas (Cl₂, NH₃, SO₂, NO_x and so on).

14. 4. Operational Environment and Operational Conditions

14.4.1. Operational Environment

This product is not water-, chemical- or corrosion-proof.

In order to prevent leakage of electricity and abnormal temperature rise of the product, do not operate under the following environmental conditions:

- (1) An atmosphere containing corrosive gas (Cl₂, NH₃, SO₂, NO_x and so on)
- (2) A high-dust environment
- (3) Under the exposure of direct sunlight
- (4) A location where the likelihood of exposure to water or water condensation exists.
- (5) A location exposed to ocean air
- (6) Any locations similar to the above

14.4.2. Operational Conditions

Please use this product within specified values (power supply, temperature, input, output and load condition, and so on). If the product is exposed to conditions outside of the specified values reliability of the product may be adversely effected.

14.4.3. Note prior to use

Diminished reliability and/ or failure may result if the product is exposed to a high-level static charge, over-rated voltage or reverse voltage. Please avoid the following conditions be avoided prior to use of the product:

- (1) Supply of power outside of rated values (see section 8)
- (2) Supply of reverse power or inadequate connection of a 0 V(DC) line
- (3) Electrostatic discharge from production line and/ or operator
- (4) Electrification of the product from electrostatic induction
- (5) Excessive mechanical shock

14.5. Transportation

Murata recommends that when transporting this product, it be packed so as to avoid damage by mechanical vibration or exposure to adverse conditions such as ocean air, high humidity. It is additionally recommended that appropriate instructions and guidelines be communicated to carriers to prevent exposure to these same conditions.

15. Note

1. Murata recommends that customers ensure that the evaluation and testing of these devices are completed with this product actually assembled on their product.
2. All the items and parameters in this product specification have been prescribed on the premise that Murata's product is used for the purpose, under the condition and in the environment mutually agreed upon.

**This document is for reference only and subject to revision without prior of subsequent notice.
Please contact Murata for latest documentation.**

Note:

1. This datasheet is downloaded from the website of Murata Manufacturing co., ltd. Therefore, it's specifications are subject to change or our products in it may be discontinued without advance notice. Please check with our sales representatives or product engineers before ordering.
2. This datasheet has only typical specifications because there is no space for detailed specifications. Therefore, please approve our product specifications or transact the approval sheet for product specifications before ordering.