

# DC-DC Converter Specification

## MPD6D20\*S

### 1 . Application

This specification applies to DC-DC Converter MPD6D20\*S(\*:7,9) for telecommunication / data-communication equipment.

For any other application, please contact us before using this product.

### 2 . Customer Reference

Customer Spec. Number

Customer Part Number

### 3 . Customer & Murata Part Number

Nominal Output Voltage	Customer Part Number	Part Number
3.3V		MPD6D207S
5.5V		MPD6D209S

#### ⚠ Note:

1. This datasheet is downloaded from the website of Murata Manufacturing co., ltd. Therefore, it' s specifications are subject to change or our products in it may be discontinued without advance notice. Please check with our sales representatives or product engineers before ordering.
2. This datasheet has only typical specifications because there is no space for detailed specifications. Therefore, please approve our product specifications or transact the approval sheet for product specifications before ordering.

## 4 . Appearance, Dimensions

Objective Products MPD6D11\*S (\* : 1,2,3,4,6,7,8,9)

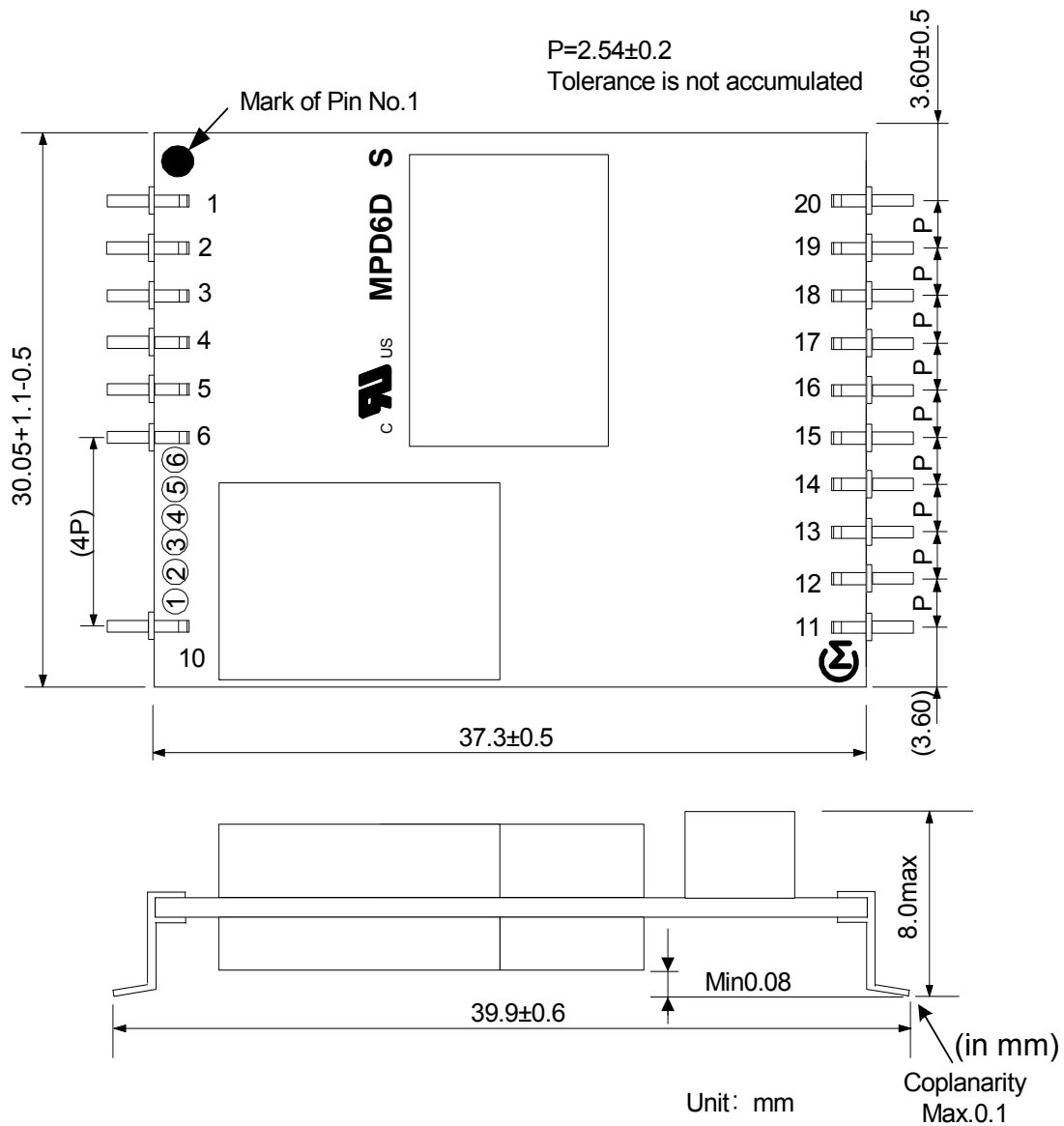

## Marking

(1) MFG ID

(2) Lot No. ①②③

① Production factory Mark

② Production Year

③ Production Month (1,2,3, ..., 9, O, N, D)

(3) Product Number

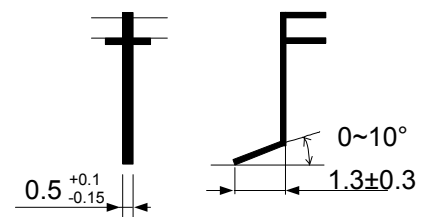
④⑤⑥ Part number of underlined MPD6D20\*S

Lead in detail

## ⚠ Note:

- This datasheet is downloaded from the website of Murata Manufacturing co., Ltd. Therefore, it's specifications are subject to change or our products in it may be discontinued without advance notice. Please check with our sales representatives or product engineers before ordering.
- This datasheet has only typical specifications because there is no space for detailed specifications. Therefore, please approve our product specifications or transact the approval sheet for product specifications before ordering.

## 5 . Pin Number and Function

Pin No	Pin Symbol	Function
1,10, 11,20	NCo	Mechanical supplemental contact pins. Pins at the four corners on printed circuit board. To contact DC-DC Converter mounted board with thermal setting resin.
2	+Vout	(+)Output
3	+Vout	(+)Output
4	+Vout	(+)Output
5	-Vout	(-)Output
6	-Vout	(-)Output
12	ALM	Alarm Output
13	RC	Remote On/Off Control
14	PO	Parallel Operation
15	NC	-
16	+Vin	(+)Input
17	+Vin	(+)Input
18	-Vin	(-)Input
19	-Vin	(-)Input

## 6. Block Diagram

### 6.1 Entire Product

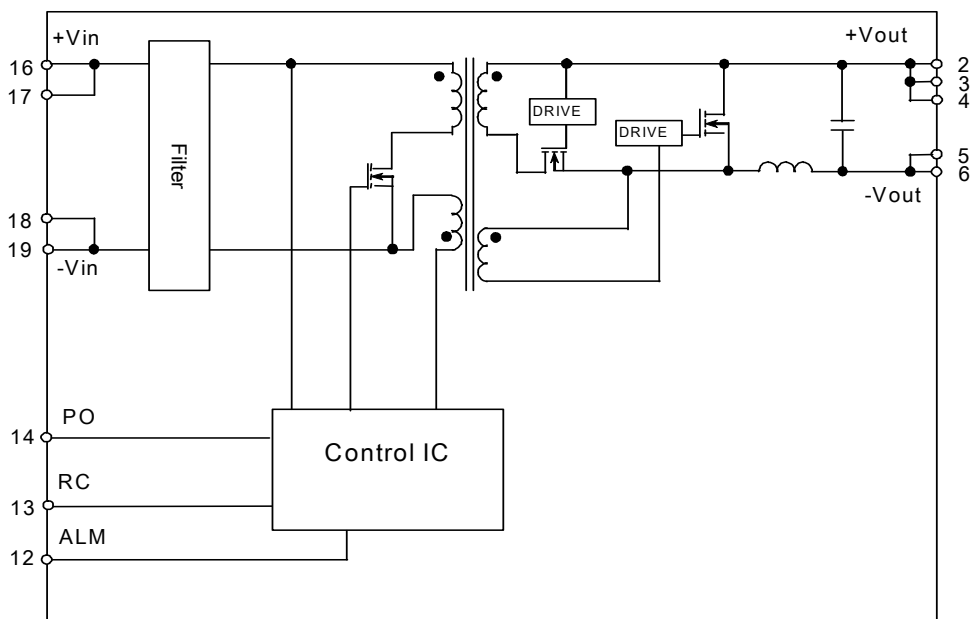

#### ⚠ Note:

1. This datasheet is downloaded from the website of Murata Manufacturing co., Ltd. Therefore, it's specifications are subject to change or our products in it may be discontinued without advance notice. Please check with our sales representatives or product engineers before ordering.
2. This datasheet has only typical specifications because there is no space for detailed specifications. Therefore, please approve our product specifications or transact the approval sheet for product specifications before ordering.

## 7. Environmental Conditions

- 7.1 Operating Temperature Range -40°C ~ +85°C (With power derated.)  
 7.2 Operating Humidity Range 20% ~ 85% (-40~ +85°C No water condenses.)  
 20% ~ 95% (-40~ +75°C No water condenses.)  
 7.3 Storage Temperature Range -45°C ~ +90°C  
 7.4 Storage Humidity Range 10% ~ 95%( No water condenses.)

## 8. Absolute Rating

Item	Unit	Absolute Rating	Remarks
Minimum Input Voltage	V	0	
Maximum Input Voltage ALM Applied Voltage RC Applied Voltage	Time	Continuous	V 36
		200µs	V 45 Slew rate 21V/10µs
PO Applied Voltage	V	8	
Maximum ALM Sink Current	mA	10	

No voltage, no matter how instantaneous, shall be applied beyond the absolute maximum voltage rating to this product.

If you apply any voltage over this limit, the product characteristics will deteriorate or the product itself will be destroyed.

Even though it may continue operating for a while after the over-voltage event, its life will likely be shortened significantly. Reliability and life of the module may degrade similarly if the maximum operating voltage rating is continuously exceeded. This product is designed to operate within the maximum operating voltage rating specification.

## 9. Characteristics

## 9.1 Electrical Characteristics (Ta=25°C)

## 9.1.1 General Characteristics

Unless otherwise specified, (Ta= -40 to +85°C with power derated.)

Item	Symbol	Condition	Value			Unit
			Min.	Typ.	Max.	
Input Voltage Range	Vin		18	24	36	V
Turn-on Input Voltage		Vin=increasing	16	-	18	V
Input Voltage difference of Turn-on and Turn-off		PO pin : Open or Connected to PO pin of other DC-DC Converters	1.0	-	-	V
Galvanic Isolation Voltage		Input time : 1 minute	1500	-	-	Vdc

Item	Standard	Note
Noise (Radiation, Conduction)	In accordance with VCCI Class A	Refer to Test Circuit in clause 10
Safety Standard(note 1)	Recognized UL60950(UL/C-UL), Complied IEC 60950	UL file No.E190503
	CE Marking	CE Mark is shown on a package box.

Note 1: 3A of input current limitation is necessary to apply to the safety standard. It is recommended that a fuse or Current Limitation Circuitry is connected to the input of DC-DC Converter. Individual input of DC-DC Converters should be limited for the application of parallel and/or multiple operations.

## ⚠ Note:

- This datasheet is downloaded from the website of Murata Manufacturing co., ltd. Therefore, it's specifications are subject to change or our products in it may be discontinued without advance notice. Please check with our sales representatives or product engineers before ordering.
- This datasheet has only typical specifications because there is no space for detailed specifications. Therefore, please approve our product specifications or transact the approval sheet for product specifications before ordering.

## 9.1.2 Specific Characteristics (Ta= -40 to +85°C with power derated.)

Part Number		MPD6D207S				
Item	Symbol	Condition	Value			Unit
			Min.	Typ.	Max.	
Nominal Output Voltage	Vo		-	3.3	-	V
Output Voltage Variation	$\Delta$ regtot	Vin=18 to 36V, Io=0 to 9 Ta=-40 to +85°C	-3		+5	%
Output Current	Io	Power derated.	0	-	9	A
Efficiency	$\eta$	at rated Vin, Io, Ta=25°C	-	91	-	%
Ripple Voltage	Vr	Refer to Test Circuit	-	-	25	mVpp
Ripple Voltage & Noise			-	-	50	
Over Current Protection	Iocp		9.2	-	-	A
Over Voltage Protection	Vovp	Output halts in latch-up mode after mask time 0.5msec (typ) to avoid malfunction by noise and transient change. Input turn off and on to reset.	3.96	-	-	V
Low Voltage Protection	Vlvp	Output halts in latch-up mode after mask time 500msec (typ) to avoid malfunction by noise and transient change. Input turn off and on to reset.	-	-	2.97	V

Part Number		MPD6D209S				
Item	Symbol	Condition	Value			Unit
			Min.	Typ.	Max.	
Nominal Output Voltage	Vo		-	5.5	-	V
Output Voltage Variation	$\Delta$ regtot	Vin=18 to 36V, Io=0 to 6 Ta=-40 to +85°C	-3		+5	%
Output Current	Io	Power derated.	0	-	6	A
Efficiency	$\eta$	at rated Vin, Io, Ta=25°C	-	91	-	%
Ripple Voltage	Vr	Refer to Test Circuit	-	-	50	mVpp
Ripple Voltage & Noise			-	-	100	
Over Current Protection	Iocp		6.2	-	-	A
Over Voltage Protection	Vovp	Output halts in latch-up mode after mask time 0.5msec (typ) to avoid malfunction by noise and transient change. Input turn off and on to reset.	6.6	-	-	V
Low Voltage Protection	Vlvp	Output halts in latch-up mode after mask time 500msec (typ) to avoid malfunction by noise and transient change. Input turn off and on to reset.	-	-	4.95	V

The above electrical characteristics are guaranteed in the condition that the impedance of the input power supply is sufficiently low as shown in clause 10.

Connecting an input inductance or using an input power supply with output inductance may cause an unstable operation of this product. Please check the proper operation of this product with the peripheral circuits on your product.

⚠ **Note:**

1. This datasheet is downloaded from the website of Murata Manufacturing co., Ltd. Therefore, it's specifications are subject to change or our products in it may be discontinued without advance notice. Please check with our sales representatives or product engineers before ordering.
2. This datasheet has only typical specifications because there is no space for detailed specifications. Therefore, please approve our product specifications or transact the approval sheet for product specifications before ordering.

## 9-1-3-1 .Typical Power Derating MPD6D207S &lt;For Reference Only&gt;

【1pcs operation use】

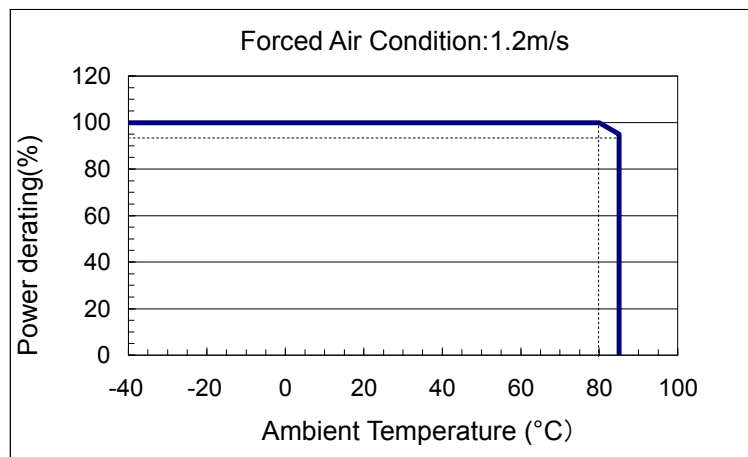
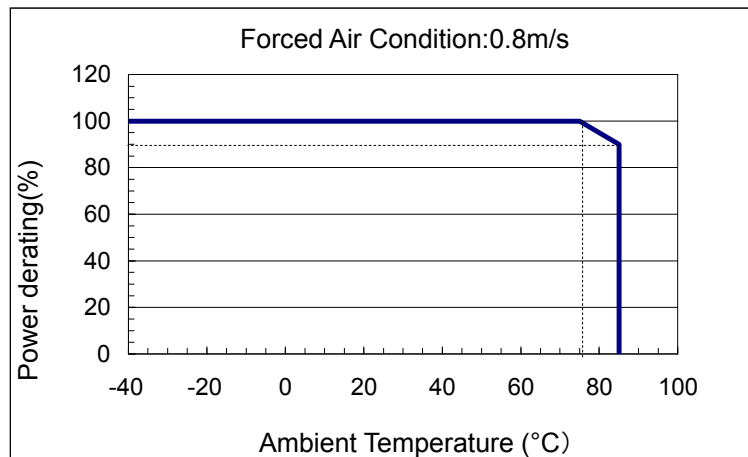
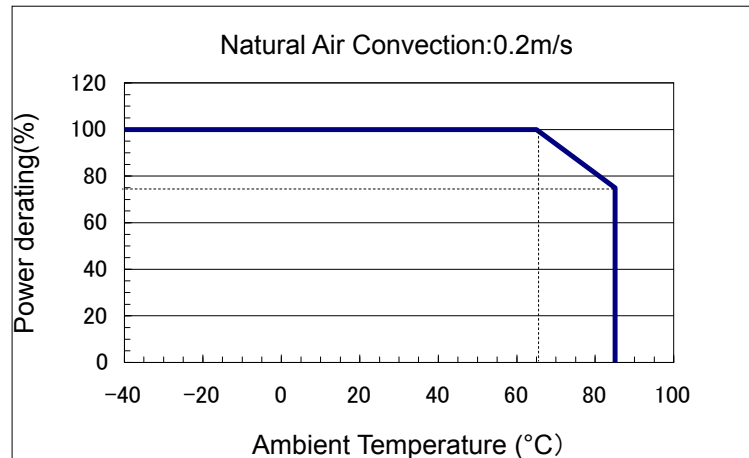

&lt;Notice&gt;

We would like to emphasize that these data are based on our experimental measurement.  
For parallel operation, Please equalize line impedance from each of DC-DC Converters.

## ⚠ Note:

1. This datasheet is downloaded from the website of Murata Manufacturing co., ltd. Therefore, it's specifications are subject to change or our products in it may be discontinued without advance notice. Please check with our sales representatives or product engineers before ordering.
2. This datasheet has only typical specifications because there is no space for detailed specifications. Therefore, please approve our product specifications or transact the approval sheet for product specifications before ordering.

## 9.1.3.2 Typical Power Derating MPD6D209S &lt;For Reference Only&gt;

【1pcs operation use】

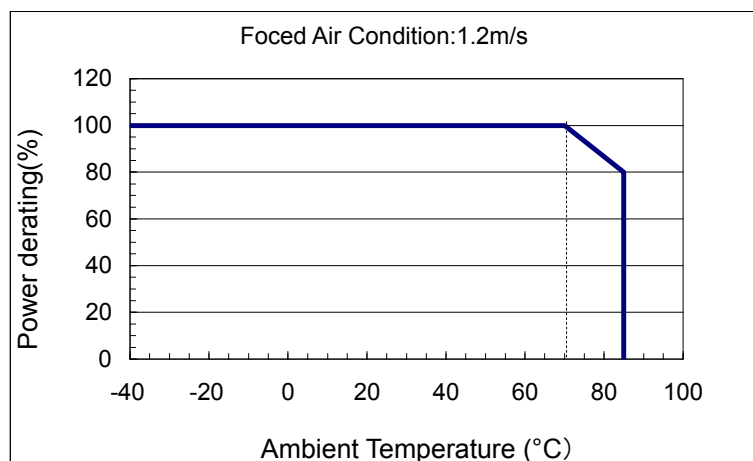
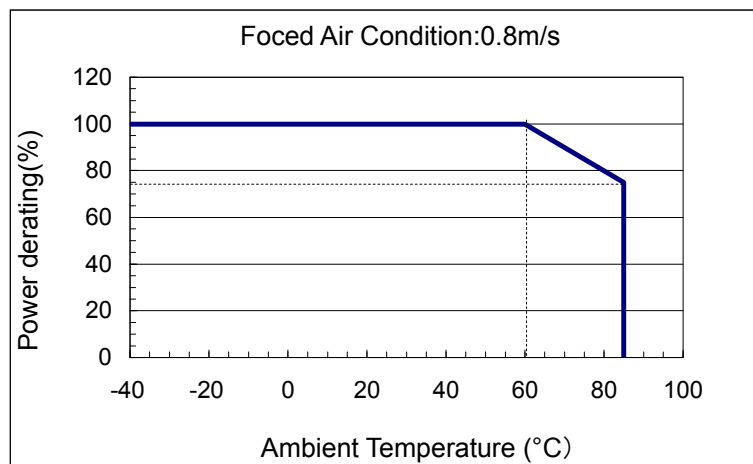
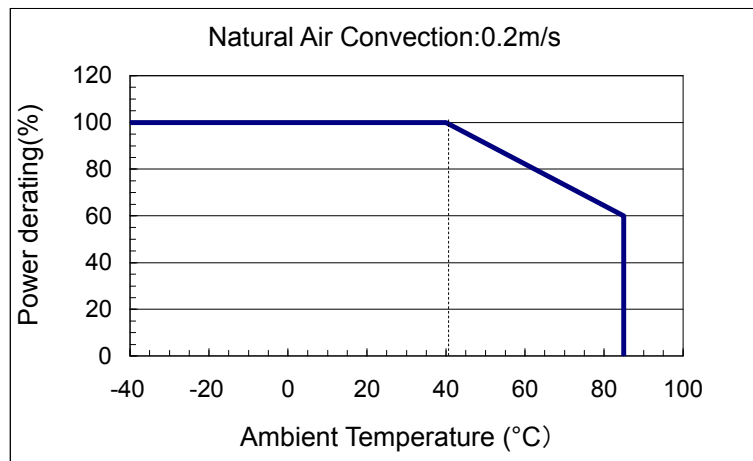

## &lt;Notice&gt;

We would like to emphasize that these data are based on our experimental measurement.  
For parallel operation, Please equalize line impedance from each of DC-DC Converters.

## ⚠ Note:

1. This datasheet is downloaded from the website of Murata Manufacturing co., ltd. Therefore, it's specifications are subject to change or our products in it may be discontinued without advance notice. Please check with our sales representatives or product engineers before ordering.
2. This datasheet has only typical specifications because there is no space for detailed specifications. Therefore, please approve our product specifications or transact the approval sheet for product specifications before ordering.

## 9-2. Operation Information

### 9-2-1. Reset Condition

In order to reset all function , the input voltage (Vin) is set under 5V for 1s. min.

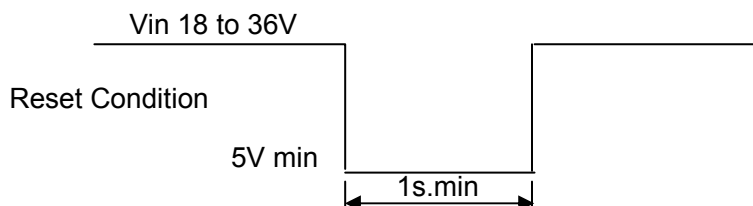

### 9-2-2. Over Voltage Protection (OVP)

The Isolated DC-DC Converter become into latch-up mode after typical 0.5ms. mask time,when the output voltage is over the value specified in Over Voltage Protection(8.1.2) by failure of internal control circuit. In order to reset, the input voltage is set under 5V for 1s. min. Output voltage might exceed the point at which OVP starts to function under the specific condition of transient input voltage or output current change. Therefore,OVP is set to wait for the mask time 0.5ms. It is recommended to evaluate your appliances installed with the DC-DC Converter.

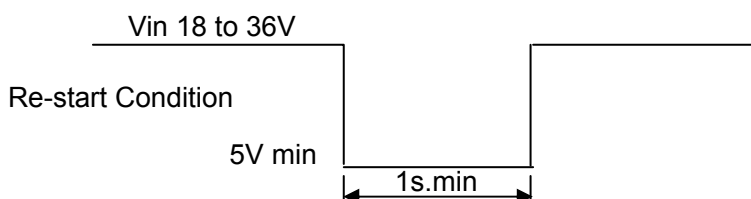

### 9-2-3. Low Voltage Protection (LVP)

The Isolated DC-DC Converter becomes into latch-up mode after typical 500ms. mask time,when the output voltage is under the value specified in Low Voltage Protection(8.1.2) by operating Over Current-limit Inception due to failure of internal control or over load. In order to reset, the input voltage is set under 5V for 1s. min.

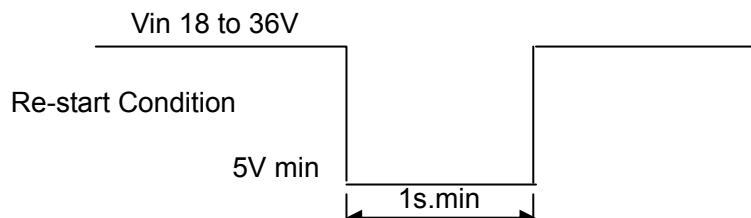

### 9-2-4. Remote On/Off Control

The connection to a RC pin controls an Isolated DC-DC Converter to turn on/off.

While the Isolated DC-DC Converter is halted under the remote control, alarm function does not operate;refer to Alarm Output.

Start : RC is open or connected to -Vin  
Halt : RC is connected to +Vin

### 9-2-5. Alarm Output (ALM)

ALM pin is down to the same voltage level of-Vin pin and sends an alarm signal. (open-drain output) Sink current in ALM pin is Max.10mA. It is possible to halt all of the connected DC-DC converters when any one is halted with over voltage protection or low voltage protection, with connecting all ALM pins for the application of parallel/multiple operation (Note 1) with plural DC-DC converters. The maximum number connecting DC-DC converters is 5pcs of parallel operation,10pcs of multiple operation ,for the purpose of halting all DC-DC converters connected with ALM pin each other. Please contact us when more than these figures.

Note 2 The parallel operation of this series is limited to only the same model.

#### ⚠ Note:

1. This datasheet is downloaded from the website of Murata Manufacturing co., ltd. Therefore, it's specifications are subject to change or our products in it may be discontinued without advance notice. Please check with our sales representatives or product engineers before ordering.
2. This datasheet has only typical specifications because there is no space for detailed specifications. Therefore, please approve our product specifications or transact the approval sheet for product specifications before ordering.



### 9-2-6.Synchronous Turn-on/off

It is possible to avoid the unevenness of turn-on timing with unifying the various Turn-on input voltage to a certain voltage which one DC-DC converter has, and with connecting PO pins each other for the application of parallel/multiple operation (Note 2) of plural DC-DC converters. It is necessary to connect PO pins for parallel operation. The maximum number connecting DC-DC converters is 5pcs of parallel operation, 10pcs of multiple operation, for the purpose of synchronous turn-on/off with connecting PO pins. Please contact us when more than these figures.

Note 2 The parallel operation of this series is limited to only the same model.

## 9. 3 Reliability

### 9. 3. 1 Reliability Test Items.

Item	Test Condition	Criteria
High Temperature	+85°C 1000hours	No damage in appearance and no deviation of electrical characteristics before and after the test.
Low Temperature	-40°C 1000hours	
Humidity	+65°C 95%RH 1000hours	
Thermal Shock	-40°C ↔ +85°C 300cycles	
Operation in High Temperature and Humidity	+85°C 85%RH 1000hour At rated input Voltage and normal output current.	
Mechanical Vibration	10 to 55Hz, max. 1.5mm amplitude, 1 hour for each of X, Y, Z directions.	
Mechanical Shock	20G, 1 time for each of X, Y, Z directions.	

### 9.3.2. Soldering Heat Resistance

Immerse the part of lead where it is to be soldered on a motherboard in a solder bath of  $260\pm 5^{\circ}\text{C}$  for  $3\pm 0.5\text{s}$ .

Then tested products are left for 2 hours.

There is no damage in appearance and no deviation from electrical characteristics in clause 9.

### 9.3.3. Lead Pin Strength

Strain a lead pin by gradual-increasingly 5.0N along axial direction; withstand for 5s.

No damage on a lead pin.

### 9.3.4. Solderability of Leads

The lead pins will be immersed in the Isopropyl Alcohol (JIS K 1522) with Rosin (JIS K5902) solution (the concentration of Rosin will be allowed 10wt% to 35wt%, and normally approx.

25wt% will be used without any specific requirement.).

Then the lead pins will be immersed in the solder H63A (JIS Z 3282) solution at the temperature of  $230^{\circ}\text{C}\pm 5^{\circ}\text{C}$  for  $3\pm 0.5\text{seconds}$ , and pulled up completely.

The solder will adhere to over 75% of immersed area.

#### ⚠ Note:

1. This datasheet is downloaded from the website of Murata Manufacturing co., Ltd. Therefore, it's specifications are subject to change or our products in it may be discontinued without advance notice. Please check with our sales representatives or product engineers before ordering.
2. This datasheet has only typical specifications because there is no space for detailed specifications. Therefore, please approve our product specifications or transact the approval sheet for product specifications before ordering.

## 10. Measure Construction

## 10-1. Standard Test Circuit

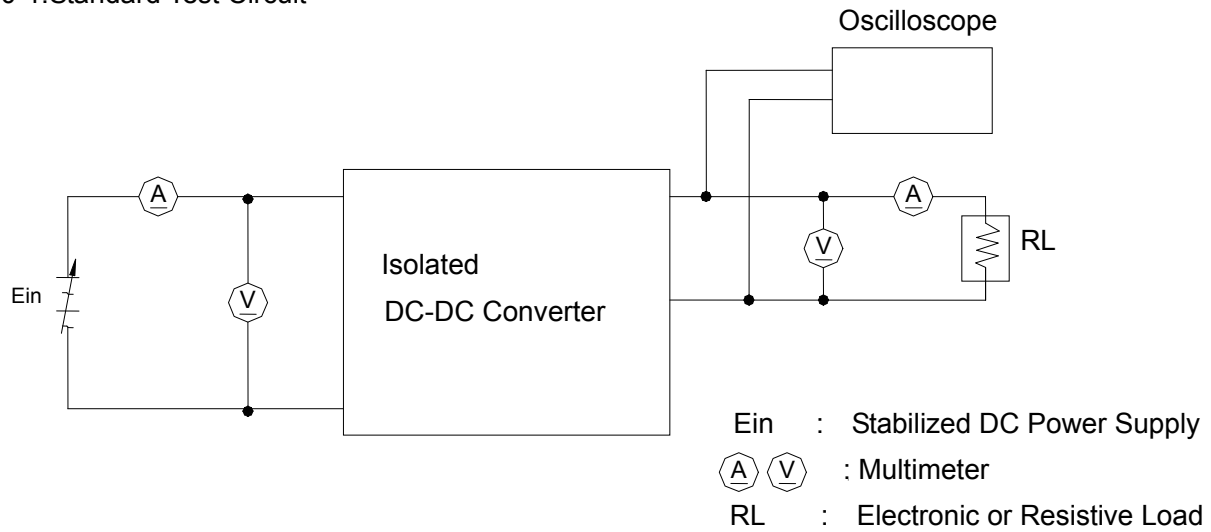

## 10.1.1 Output Ripple &amp; Noise

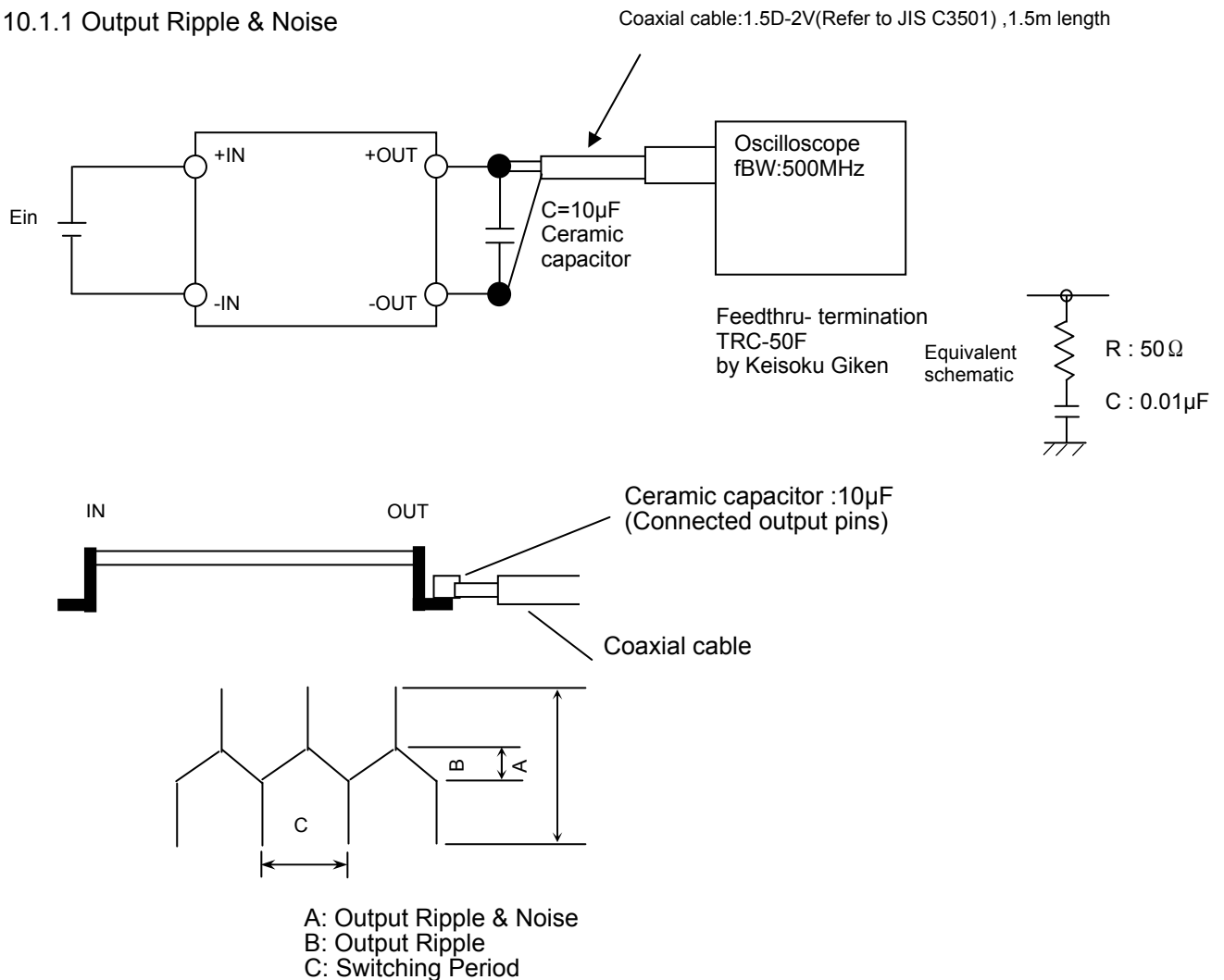

## ⚠ Note:

1. This datasheet is downloaded from the website of Murata Manufacturing co., Ltd. Therefore, it's specifications are subject to change or our products in it may be discontinued without advance notice. Please check with our sales representatives or product engineers before ordering.
2. This datasheet has only typical specifications because there is no space for detailed specifications. Therefore, please approve our product specifications or transact the approval sheet for product specifications before ordering.

## 10.1.2. Radiation Noise

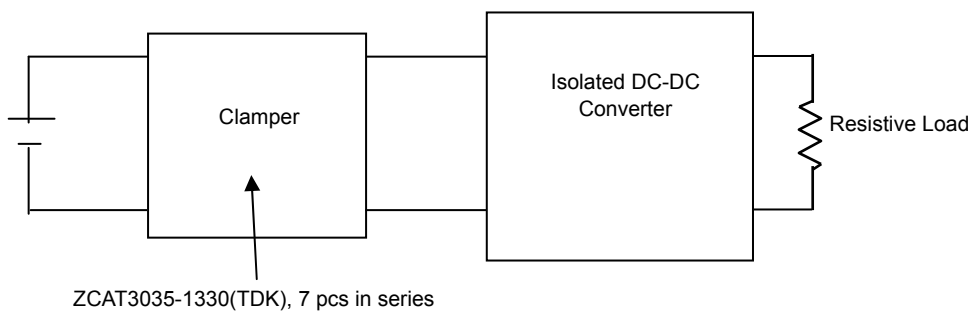

## 10.1.3. Conduction Noise

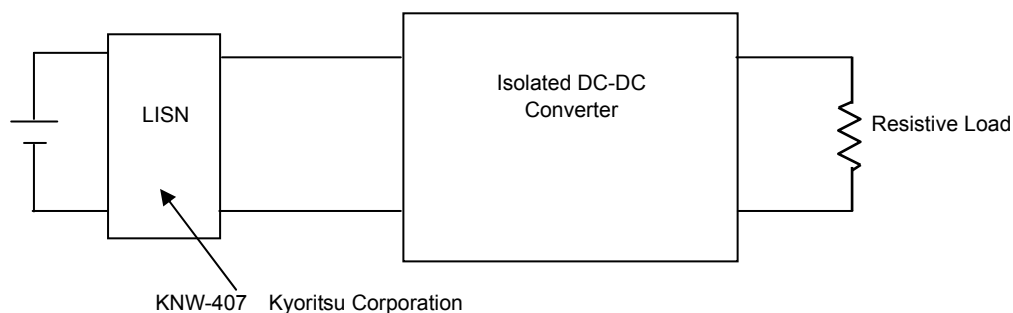

(Note) Measurement at Radiation Noise, Conductive Noise, Output ripple & Noise.

Please measure Radiation Noise, Conductive Noise and Output ripple & Noise with conforming to the Test Circuit in clause 10

Otherwise the noise might not meet the specified values.

⚠ **Note:**

1. This datasheet is downloaded from the website of Murata Manufacturing co., ltd. Therefore, it's specifications are subject to change or our products in it may be discontinued without advance notice. Please check with our sales representatives or product engineers before ordering.
2. This datasheet has only typical specifications because there is no space for detailed specifications. Therefore, please approve our product specifications or transact the approval sheet for product specifications before ordering.

## 11. Packaging Information

## 11.1 Tray Dimensions

DC-DC Converters are put in the trays.

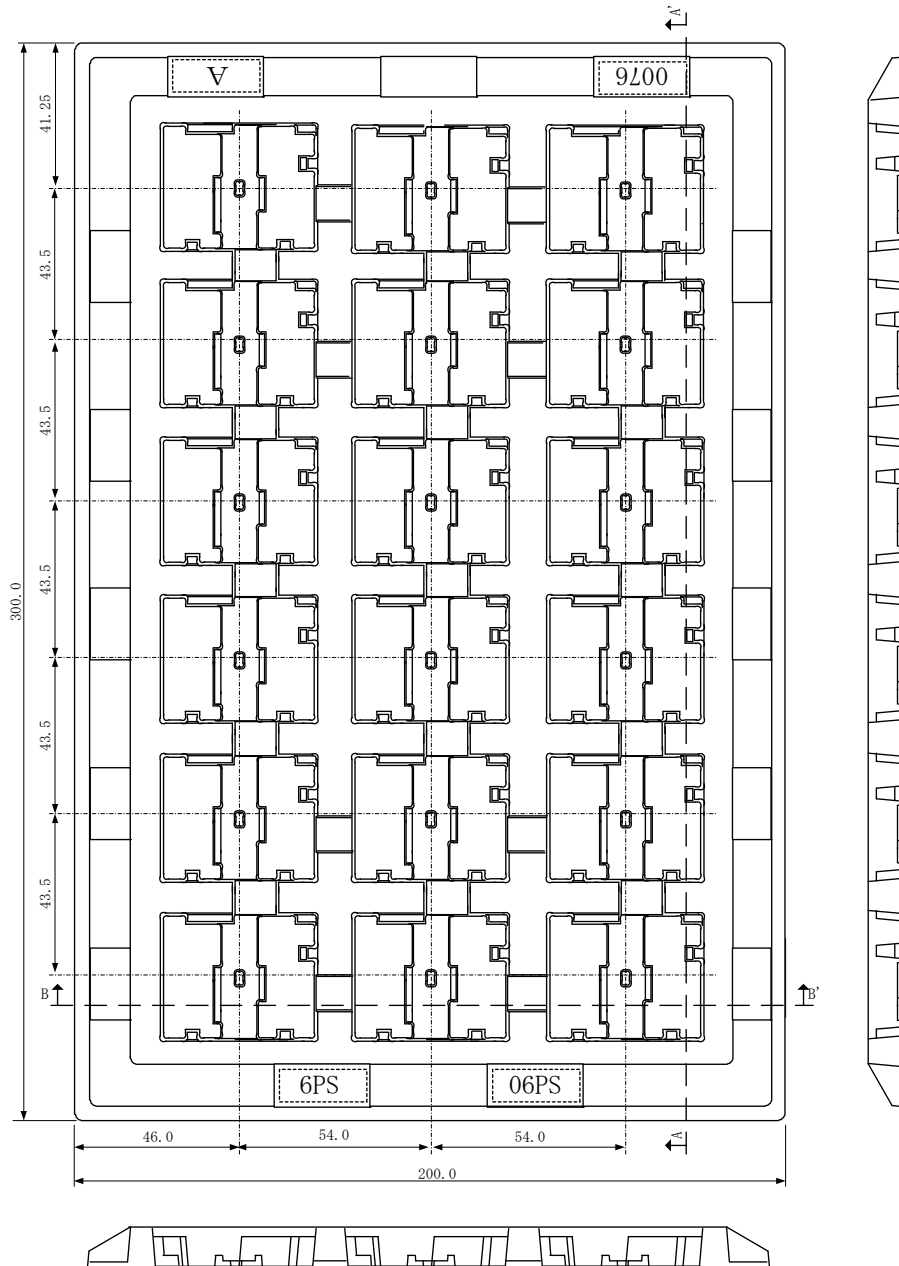

Fig.1

## 11-2. Contained pieces of products per corrugated box.

Maximum Contained products pieces 72 pcs/corrugated box.

Further plural sheets of corrugated cardboard are placed on the top of the dummy tray according to number of contained trays in order to full up the space in a corrugated box.

⚠ **Note:**

1. This datasheet is downloaded from the website of Murata Manufacturing co., ltd. Therefore, it's specifications are subject to change or our products in it may be discontinued without advance notice. Please check with our sales representatives or product engineers before ordering.
2. This datasheet has only typical specifications because there is no space for detailed specifications. Therefore, please approve our product specifications or transact the approval sheet for product specifications before ordering.

### 11-3. Packaging Form

Trays with products are lidded and packed in a corrugated box. (See Fig.2)

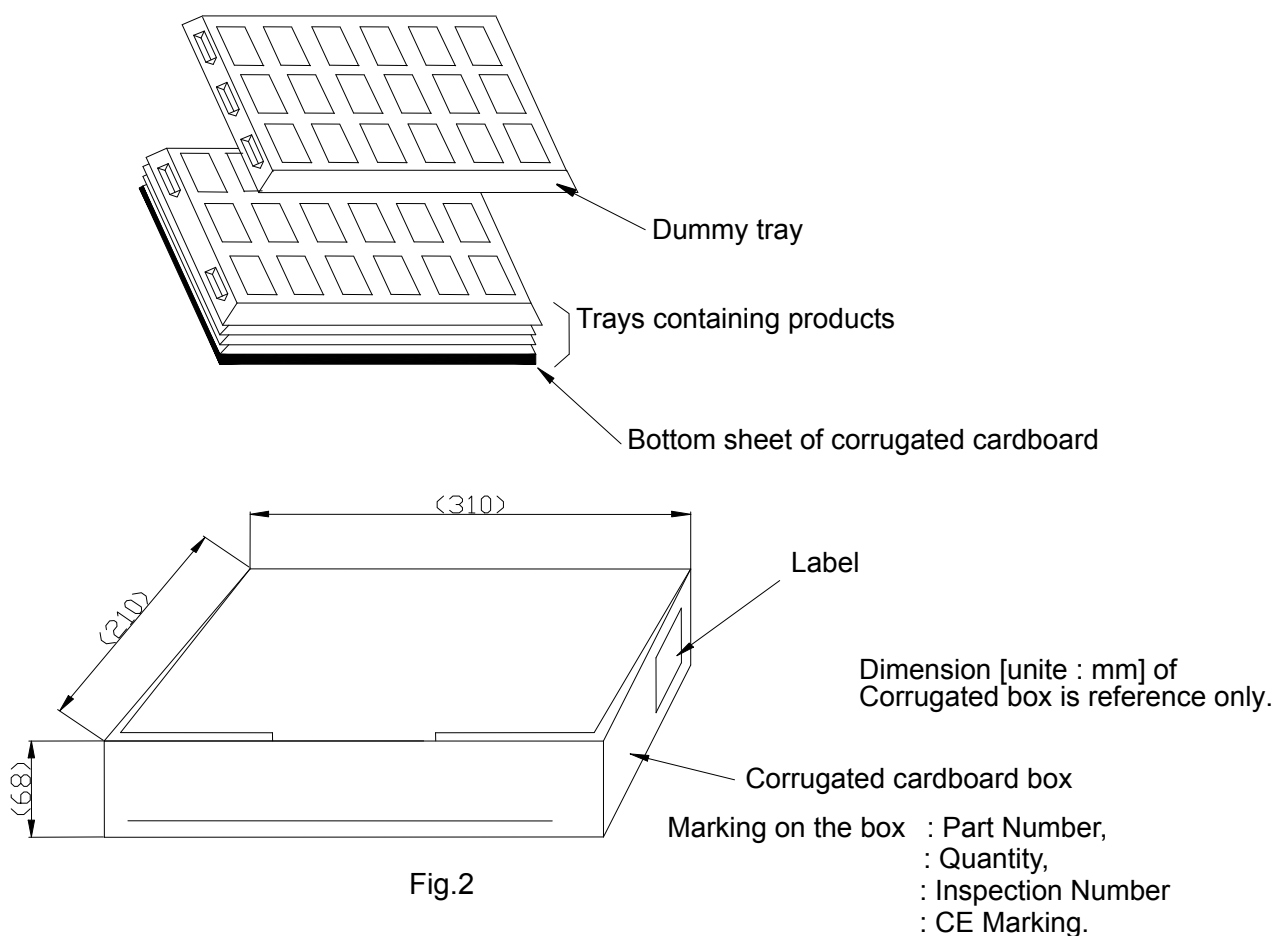

Fig.2

### 12. Production factory

Komatsu Murata Mfg.Co.,Ltd.

Kanazu Murata Mfg.Co.,Ltd.

Wakura Murata Mfg.Co.,Ltd.

#### ⚠ Caution

1. Be sure to provide an appropriate fail-safe function on your product to prevent secondary damage that may be caused by the functional trouble or the failure of this product.
2. Please contact us before using this product for the applications listed below which require especially high reliability for the prevention of defects and failure, which might directly cause damage to the third party's life, body or property.
 

① Aircraft equipment	② Aerospace equipment
③ Undersea equipment	④ Power plant control equipment
⑤ Medical equipment	⑥ Transportation equipment (vehicles, trains, ships, etc.)
⑦ Traffic signal equipment	⑧ Disaster prevention /crime prevention equipment
⑨ Any other application of similar complexity and/or reliability requirements to the applications listed above.	

#### ⚠ Note:

1. This datasheet is downloaded from the website of Murata Manufacturing co., ltd. Therefore, it's specifications are subject to change or our products in it may be discontinued without advance notice. Please check with our sales representatives or product engineers before ordering.
2. This datasheet has only typical specifications because there is no space for detailed specifications. Therefore, please approve our product specifications or transact the approval sheet for product specifications before ordering.

 Note

1. Please make sure that the evaluation and testing are completed with this product actually assembled on your product.
2. All the items and parameters in this product specification have been prescribed on the premise that our product is used for the purpose, under the condition and in the environment mutually agreed upon. Please do not to use this product deviating from such agreement.
3. We consider it not appropriate to include other terms and conditions for transaction warranty in product specifications, drawings or other technical documents. Therefore, if your technical documents include such terms and conditions as warranty clause, product liability clause, or intellectual property infringement liability clause, we will not be able to accept such terms and conditions unless they are based on the governmental regulation or they are stated in a separate contract agreement.

### 13. Notice

#### 13.1. Soldering

##### 13.1.1. Flux

Please solder this product with Rosin Flux, which contains of 0.2wt% or less chlorine. Please do not use high activity acid flux or water soluble flux because they may erode metal or glass portion of this product and may cause defectiveness or deterioration of this product.

##### 13.1.2. Solder

Please use the solder H60, H63(JIS Z3282)or the equivalent type. Please use the solder paste of equivalent type H60, H63.

##### 13.1.3. Recommended Soldering Conditions

###### Reflow Solder

Reflow Soldering Profiles  
JEDEC IPC/JEDEC J-STD-020C  
Table 5-2 Classification Reflow Profiles  
Pb-Free Assembly Large Body

###### Profile details

Soldering temperature	: 245 °C +0/-5
Soldering time	: 20~40 seconds, 240~245 °C
Heating time	: 60~150 seconds, 217 °C or more.
Preheating time	: 60~180seconds, 150~200 °C
Programming rate	: 3 °C /sec.Max., 217~245 °C
Descending rate	: 6 °C /sec.Max.
Total soldering time	: 8 minutes Max., 25~245 °C
Time	: 1times

※The solder used to this product is melted in reflow process.

Therefore do not add excessive vibration and strong air below to this product during reflow. Please take out the products from a reflow furnace after the product temperature is cooled down thoroughly.

Please do NOT mount Isolated DC-DC Converter on backside of a motherboard like the below figure due to the possibility to drop the Isolated DC-DC Converter during reflow process.

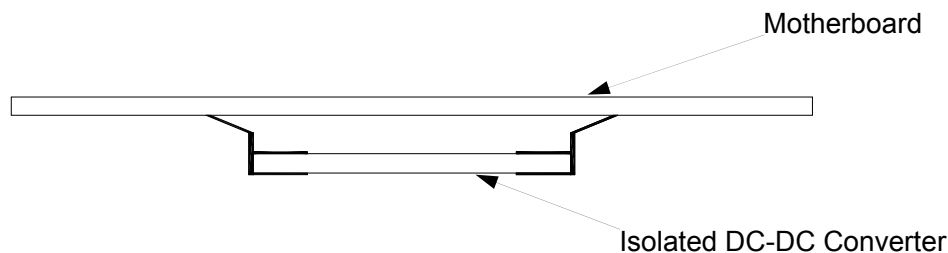

 Note:

1. This datasheet is downloaded from the website of Murata Manufacturing co., Ltd. Therefore, it's specifications are subject to change or our products in it may be discontinued without advance notice. Please check with our sales representatives or product engineers before ordering.
2. This datasheet has only typical specifications because there is no space for detailed specifications. Therefore, please approve our product specifications or transact the approval sheet for product specifications before ordering.

### 13.2. Cleaning

13.2.1. Please clean this product to remove flux by using dip, boil, and vapor methods in isopropyl alcohol for up to 5 minutes.

Please inform us if you are to use aqueous or semi-aqueous cleaning or other methods.

Do not use ultrasonic cleaning because semiconductor device on this product maybe damaged by resonance.

13.2.2. After cleaning, please dry this product thoroughly.

If you touch the wet product, marking maybe erased or blurred.

Do not measure electrical characteristics, until this product gets dried enough.

13.2.3. If you don't clean this product with no-cleaning type flux, you must confirm fully in advance the reliability of this product.

### 13.3. Storage

13.3.1. Please store the products in room where the temperature/humidity is stable and direct sunlight cannot come in, and use the products within 6 months after delivery.

Please avoid damp and heat or such places where the temperature greatly changes, as water may condense on this product, and the quality of characteristics may be reduced, and/or be the solderability may be degraded.

If this product needs to be stored for a long time (more than 1 year), this product may be degraded in solderability and/or corroded. Please test the solderability of this product regularly.

Baking before reflow process is unnecessary to store the products under 30 °C,60%RH or less up to 6 months.

If the storage condition is over above mentioned, recommend a baking at 100±5 °C,24 hours before reflow process.

13.3.2. Please do not store this product in the conditions such as a dusty place, a place exposed directly to sea breeze, or in an atmosphere containing corrosive gas (Cl<sub>2</sub>, NH<sub>3</sub>, SO<sub>2</sub>, NO<sub>X</sub> and so on).

### 13.4. Operational Environment and Operational Conditions

#### 13.4.1. Operational Environment

This product is not water-, chemical- or corrosion-proof.

In order to prevent leakage of electricity and abnormal temperature rise of this product, do not use this product in the following conditions:

- (1) in an atmosphere containing corrosive gas (Cl<sub>2</sub>, NH<sub>3</sub>, SO<sub>2</sub>, NO<sub>X</sub> and so on)
- (2) in a dusty place
- (3) in a place exposed to direct sunlight
- (4) in such a place where water splashes or in such a humid place where water condenses
- (5) in a place exposed to sea breeze
- (6) in any other places similar to the above

#### 13.4.2. Operational Conditions

Please use this product within specified values (power supply, temperature, input, output, load condition, and so on).

If not used within the specified values, defectiveness and deterioration of this product may be caused.

Even if this product can endure the condition for short time, it may cause degradation of reliability.

It is recommended that a fuse is inserted in input line (Vin) to secure safety in any abnormality such as internal circuit of Isolated DC-DC Converter broken down.

Also please take care that the external voltage over output voltage of DC-DC Converter does not applies to output of this Isolated DC-DC Converter.

#### ⚠ Note:

1. This datasheet is downloaded from the website of Murata Manufacturing co., Ltd. Therefore, it's specifications are subject to change or our products in it may be discontinued without advance notice. Please check with our sales representatives or product engineers before ordering.
2. This datasheet has only typical specifications because there is no space for detailed specifications. Therefore, please approve our product specifications or transact the approval sheet for product specifications before ordering.

### 13.4.3. Note prior to use

Defectiveness and reliability degradation may be caused if high static electricity, over rated voltage or reverse voltage are applied to this product. Please be sure to avoid the followings:

- (1) over rating power supply, reverse power supply or inadequate connection of 0 V(DC)line
- (2) electrostatic discharge from production line and/or operator
- (3) electrified product from electrostatic induction

Please avoid an excessive mechanical shock.

If this product is dropped on the floor, etc., a crack to the core of inductors and monolithic ceramic capacitors may occur.

Please handle with care to avoid a strong shock to this product.

Do not give excessive mechanical stress to the product with your handling.

Please control to bend in a maximum of 0.2mm in your application.

Please keep the temperature 120 °C or less ,where the components shown in below are measured, under the application of forced air convection.

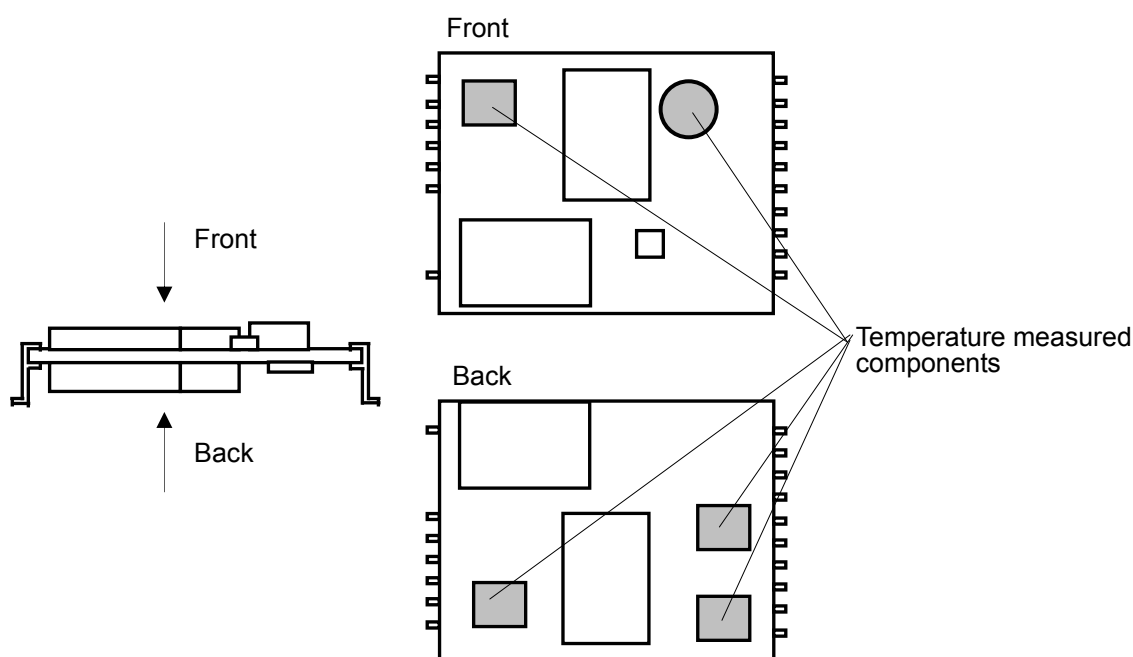

### 13.5. Transportation

When transporting this product, please pack it in order to avoid damage by mechanical vibration or mechanical shock, and please give instructions and set guidelines to the carriers to prevent rough handling.

When transporting this product overseas (in particular, by sea), bad environment of transportation may be expected, therefore please pack this product considering mechanical strength, vibration-resistance and humidity-resistance.

The packaging designed for domestic sales may not suitable for overseas transportation.

Please contact us if this product with domestic packing is transported overseas.

**The document is for reference only and is subject to revision without notices.  
Please contact Murata for formal documentation.**

#### ⚠ Note:

1. This datasheet is downloaded from the website of Murata Manufacturing co., Ltd. Therefore, it's specifications are subject to change or our products in it may be discontinued without advance notice. Please check with our sales representatives or product engineers before ordering.
2. This datasheet has only typical specifications because there is no space for detailed specifications. Therefore, please approve our product specifications or transact the approval sheet for product specifications before ordering.