

Features

- ESD Protect for 1 Line with Uni-directional
- Provide ESD protection for the protected line to **IEC 61000-4-2 (ESD) $\pm 15\text{kV}$ (air/contact)**
IEC 61000-4-4 (EFT) 40A (5/50ns)
Cable Discharge Event (CDE)
- **0201 small DFN package** saves board space
- Protect one I/O line or one power line
- Fast turn-on and Low clamping voltage
- For low operating voltage applications: 5V maximum
- Solid-state silicon-avalanche and active circuit triggering technology
- Green part

Applications

- Mobile Phones
- Hand Held Portable Applications
- Computer Interfaces Protection
- Microprocessors Protection
- Serial and Parallel Ports Protection
- Control Signal Lines Protection
- Power lines on PCB Protection
- Latchup Protection

Description

AZ5A15-01F is a design which includes one Unidirectional ESD rated clamping cell to protect one power line, or one control line, or one low speed data line in an electronic systems. The AZ5A15-01F has been specifically designed to protect sensitive components which are connected to power and control lines from over-voltage damage and latch-up caused by Electrostatic Discharging (ESD), Electrical Fast Transients (EFT), and Cable Discharge Event (CDE).

AZ5A15-01F is a unique design which includes

proprietary clamping cell in a single package. During transient conditions, the proprietary clamping cell prevents over-voltage on the power line or control/data lines, protecting any downstream components.

AZ5A15-01F may be used to meet the ESD immunity requirements of IEC 61000-4-2, Level 4 ($\pm 15\text{kV}$ air, $\pm 8\text{kV}$ contact discharge)

Circuit Diagram / Pin Configuration

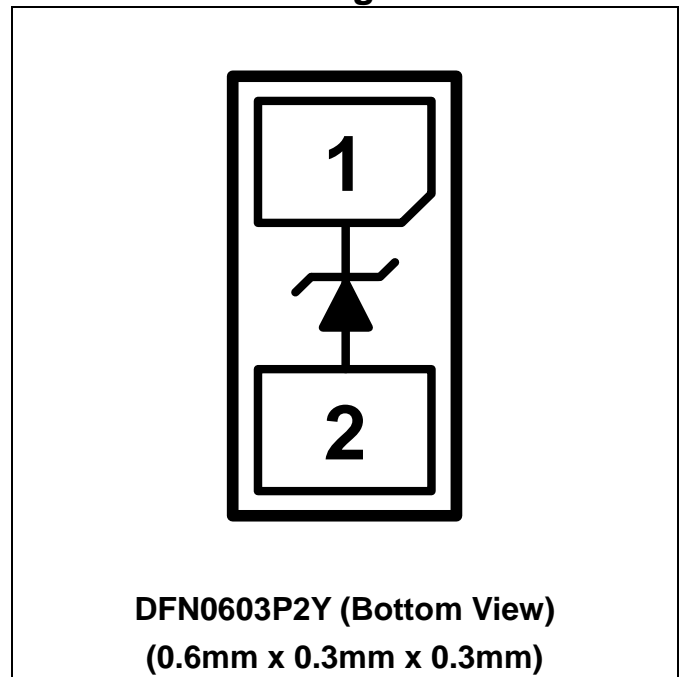

SPECIFICATIONS

ABSOLUTE MAXIMUM RATINGS			
PARAMETER	PARAMETER	RATING	UNITS
Operating Supply Voltage	V_{DC}	6	V
ESD per IEC 61000-4-2 (Air)	V_{ESD}	± 15	kV
ESD per IEC 61000-4-2 (Contact)		± 15	
Lead Soldering Temperature	T_{SOL}	260 (10 sec.)	$^{\circ}C$
Operating Temperature	T_{OP}	-55 to +85	$^{\circ}C$
Storage Temperature	T_{STO}	-55 to +150	$^{\circ}C$

ELECTRICAL CHARACTERISTICS						
PARAMETER	SYMBOL	CONDITIONS	MINI	TYP	MAX	UNITS
Stand-Off Voltage	V_{RWM}	$T=25^{\circ}C$, pin-1 to pin-2.			5	V
Leakage Current	I_{Leak}	$V_{RWM} = 5V$, $T=25^{\circ}C$.			1	μA
Breakdown Voltage	V_{BV}	$I_{BV} = 1mA$, $T=25^{\circ}C$, pin-1 to pin-2.	6		9	V
Forward Voltage	V_F	$I_F = 15mA$, $T=25^{\circ}C$, pin-2 to pin-1.		0.85	1.1	V
ESD Clamping Voltage	V_{ESD_CL}	IEC 61000-4-2 +6kV, $T=25^{\circ}C$, Contact mode, pin-1 to pin-2.		11		V
Channel Input Capacitance	C_{IN}	$V_R = 0V$, $f = 1MHz$, $T=25^{\circ}C$, pin-1 to pin-2.		9	11	pF

Typical Characteristics

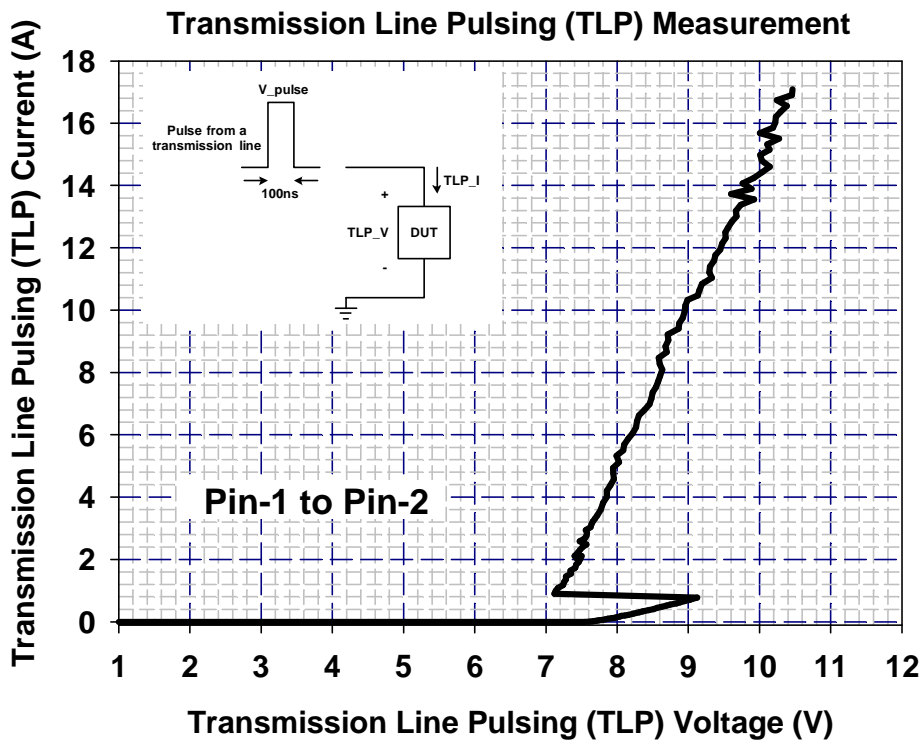
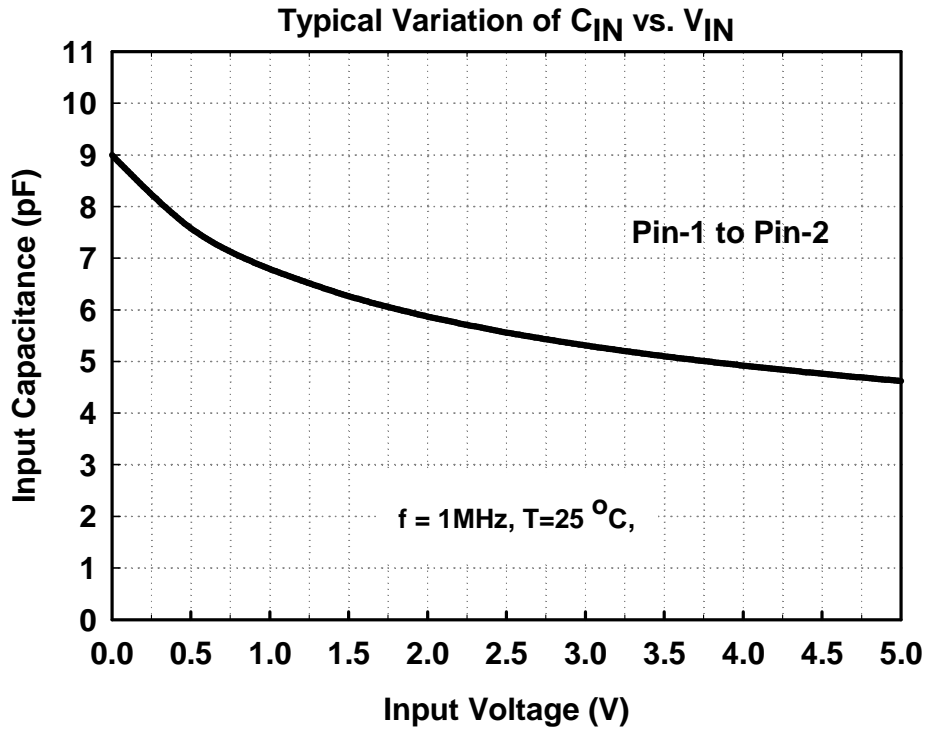

Applications Information

The AZ5A15-01F is designed to protect one line against System ESD/EFT/Cable-Discharge pulses by clamping it to an acceptable reference. It provides unidirectional protection.

The usage of the AZ5A15-01F is shown in Fig. 1. Protected line, such as data line, control line, or power line, is connected at pin 1. The pin 2 is connected to a ground plane on the board. In order to minimize parasitic inductance in the board traces, all path lengths connected to the pins of AZ5A15-01F should be kept as short as possible.

In order to obtain enough suppression of ESD induced transient, good circuit board is critical. Thus, the following guidelines are recommended:

- Minimize the path length between the protected lines and the AZ5A15-01F.
- Place the AZ5A15-01F near the input terminals or connectors to restrict transient coupling.
- The ESD current return path to ground should be kept as short as possible.
- Use ground planes whenever possible.
- NEVER route critical signals near board edges and near the lines which the ESD transient easily injects to.

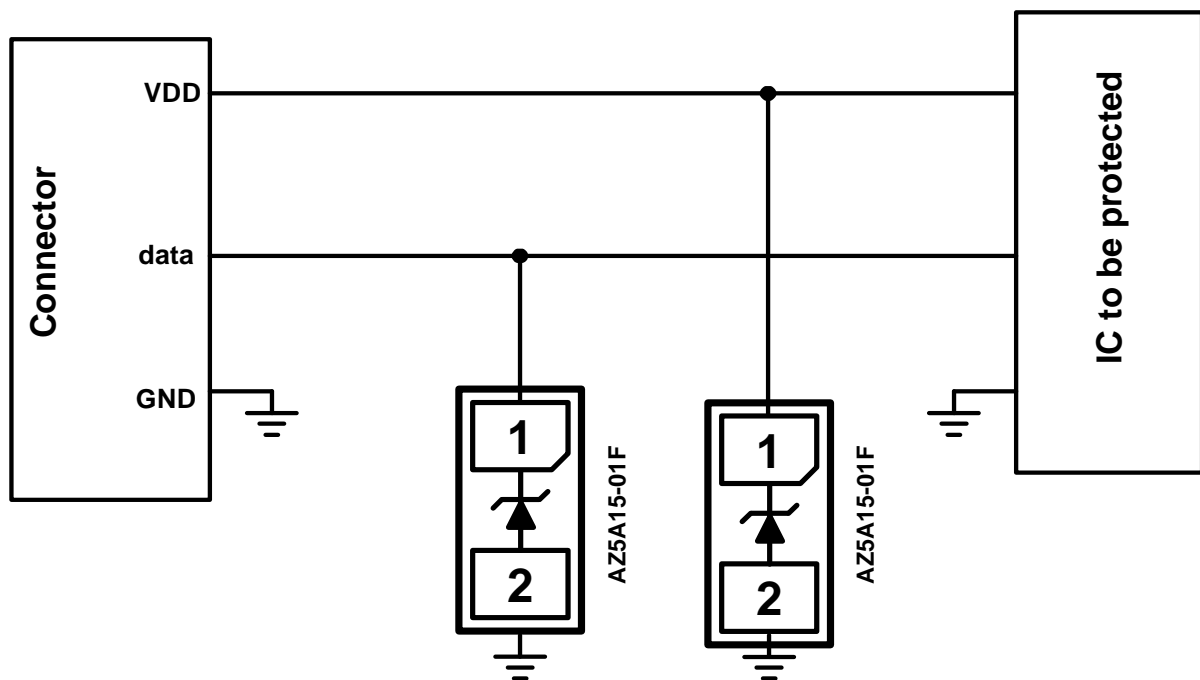

Fig. 1

Fig. 2 shows another simplified example of using AZ5A15-01F to protect the control line, low speed data line, and power line from ESD transient stress.

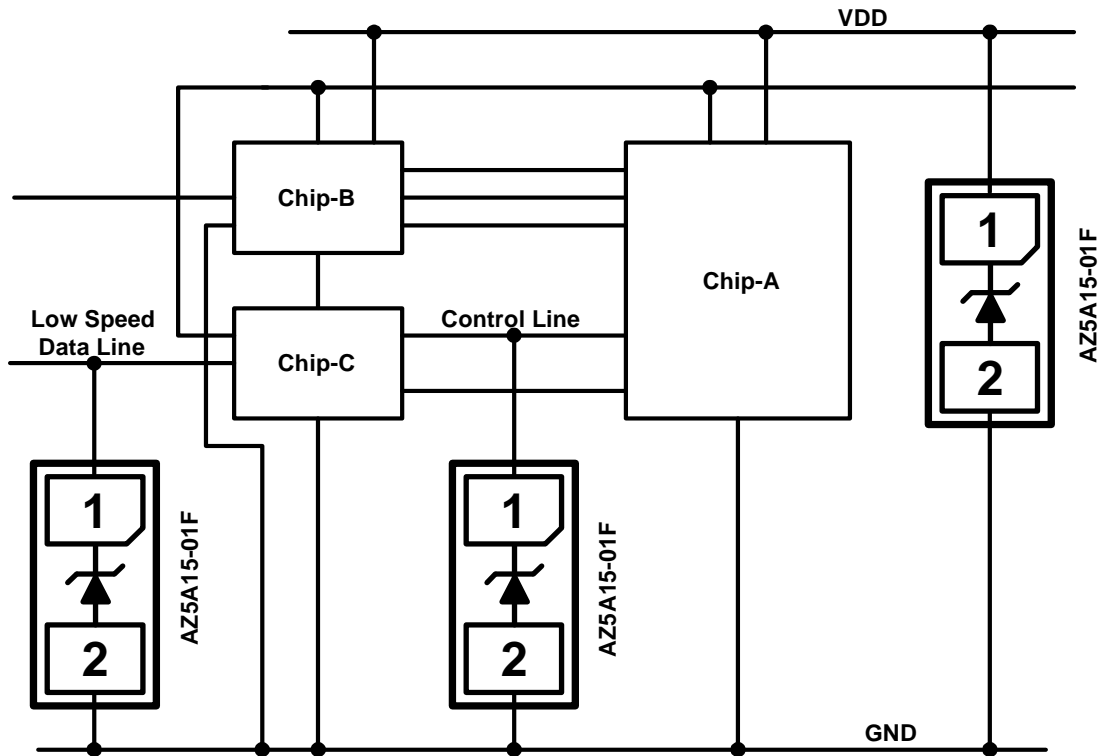
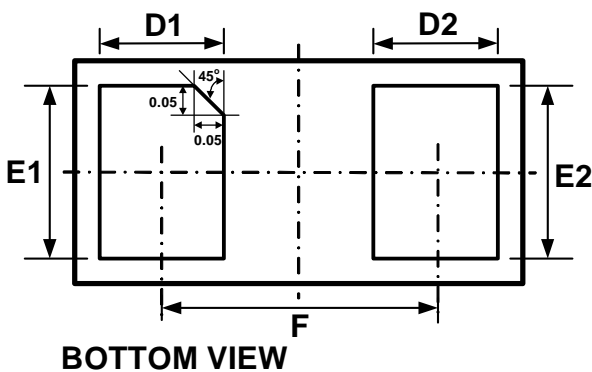
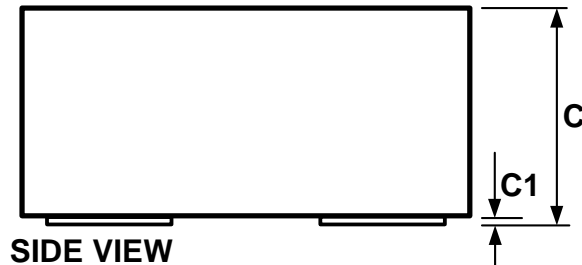
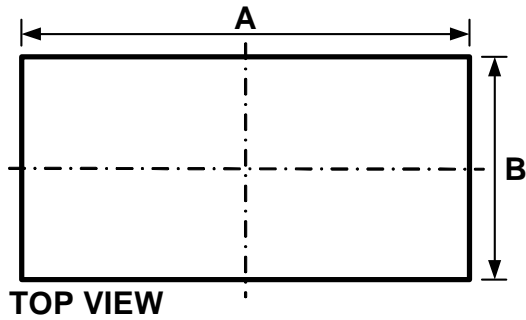

Fig. 2

Mechanical Details

DFN0603P2Y PACKAGE DIAGRAMS



SYMBOL	Millimeters		
	MIN.	NOM.	MAX.
A	0.55	0.60	0.65
B	0.25	0.30	0.35
C	0.28	0.30	0.32
C1	0.00	0.02	0.05
D1	0.13	0.18	0.23
D2	0.14	0.19	0.24
E1/E2	0.20	0.25	0.30
F	0.35		

LAND LAYOUT

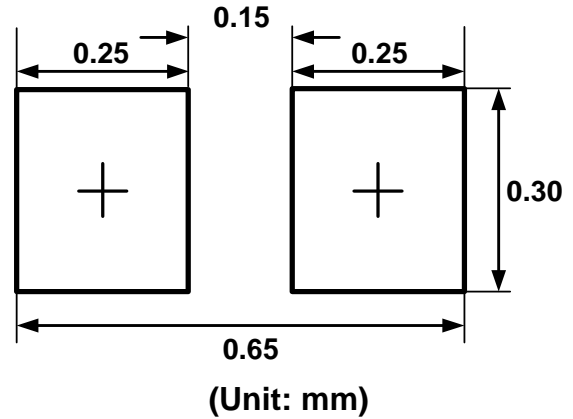

Notes:

This LAND LAYOUT is for reference purposes only. Please consult your manufacturing partners to ensure your company's PCB design guidelines are met.

MARKING CODE

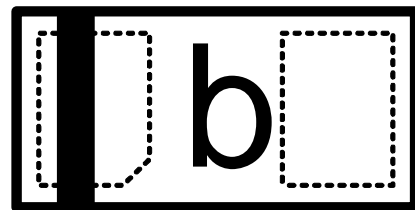

Part Number	Marking Code
AZ5A15-01F	b
AZ5A15-01F (Engineering)	K

Revision History

Revision	Modification Description
Revision 2010/05/12	Preliminary Release.
Revision 2011/01/17	Formal Release.
Revision 2011/03/11	1. Correct the typo at V_{DC} . 2. Add pin description in ELECTRICAL CHARACTERISTICS.