

Pressure Switch Design with Semiconductor Pressure Sensors

by: Eric Jacobsen and Jeff Baum
Sensor Design and Applications Group, Phoenix, AZ

INTRODUCTION

The Pressure Switch concept is simple, as are the additions to conventional signal conditioning circuitry required to provide a pressure threshold (or thresholds) at which the output switches logic state. This logic-level output may be input to a microcontroller, drive an LED, control an electronic switch, etc. The user-programmed threshold (or reference voltage) determines the pressure at which the output state will switch. An additional feature of this minimal component design is an optional user-defined hysteresis setting that will eliminate multiple output transitions when the pressure sensor voltage is comparable to the threshold voltage.

This paper presents the characteristics and design criteria for each of the major subsystems of the pressure switch design: the pressure sensor, the signal conditioning (gain) stage, and the comparator output stage. Additionally, an entire section will be devoted to comparator circuit topologies which employ comparator ICs and/or operational amplifiers. A window comparator design (high and low thresholds) is also included. This section will discuss the characteristics and design criteria for each comparator circuit, while evaluating them in overall performance (i.e., switching speed, logic-level voltages, etc.).

BASIC SENSOR OPERATION

The MPX2000 Series sensors are temperature compensated and calibrated (i.e., offset and full-scale span are precision trimmed) pressure transducers. These sensors are available in full-scale pressure ranges from 10 kPa (1.5 psi) to 200 kPa (30 psi). Although the specifications (see [Table 1](#)) in the data sheets apply only to a 10 V supply voltage, the output of these devices is ratiometric with the supply voltage. For example, at the absolute maximum supply voltage rating, 16 V, the sensor will produce a differential output voltage of 64 mV at the rated full-scale pressure of the given sensor. One exception to this is that the full-scale span of the MPX2010 (10 kPa sensor) will be only 40 mV due to the device's slightly lower sensitivity. Since the maximum supply voltage produces the most output voltage, it is evident that even the best case scenario will require some signal conditioning to obtain a usable voltage level. For this specific design, an MPX2100 and 5.0 V supply is used to provide a maximum sensor output of 20 mV. The sensor output is then signal conditioned to obtain a four volt signal swing (span).

Table 1. MPX2100 Electrical Characteristics for $V_S = 10\text{ V}$, $T_A = 25^\circ\text{C}$

Characteristics	Symbol	Minimum	Typical	Maximum	Unit
Pressure Range	P_{OP}	0	—	100	kPa
Supply Voltage	V_S	—	10	16	V_{DC}
Full Scale Span	V_{FSS}	38.5	40	41.5	mV
Zero Pressure Offset	V_{OFF}	—	0.05	0.1	mV
Sensitivity	S	—	0.4	—	mV/kPa
Linearity	—	—	0.05	—	% F_{SS}
Temperature Effect on Span	—	—	0.5	—	% F_{SS}
Temperature Effect on Offset	—	—	0.2	—	% F_{SS}

THE SIGNAL CONDITIONING

The amplifier circuitry, shown in [Figure 1](#), is composed of two op-amps. This interface circuit has a much lower component count than conventional quad op amp instrumentation amplifiers. The two op amp design offers the high input impedance, low output impedance, and high gain desired for a transducer interface, while performing a differential to single-ended conversion. The gain is set by the following equation:

$$\text{GAIN} = 1 + \frac{R_6}{R_5}$$

where $R_6 = R_3$ and $R_4 = R_5$

For this specific design, the gain is set to 201 by setting $R_6 = 20 \text{ k}\Omega$ and $R_5 = 100 \Omega$. Using these values and setting $R_6 = R_3$ and $R_4 = R_5$ gives the desired gain without loading the reference voltage divider formed by R_1 and R_{off} . The offset voltage is set via this voltage divider by choosing the value of R_{off} . This enables the user to adjust the offset for each application's requirements.

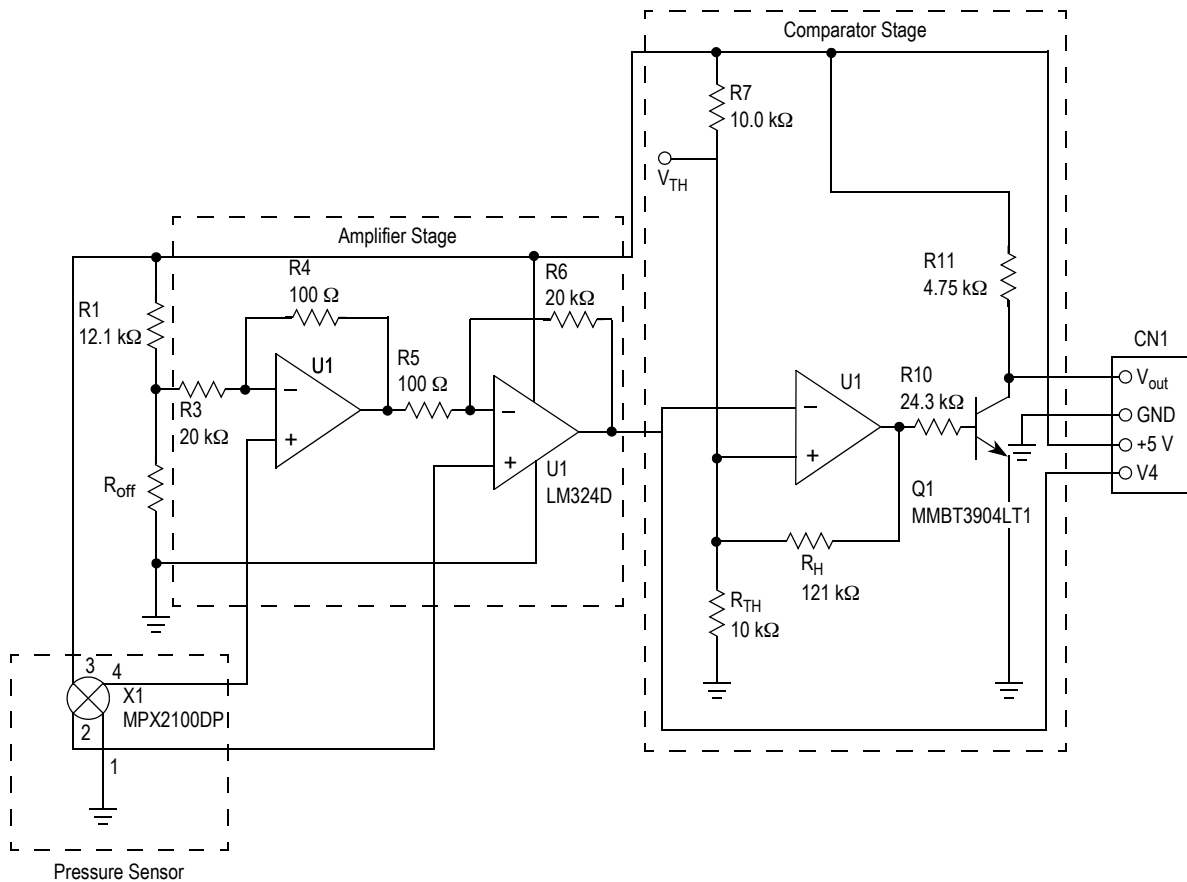

Figure 1. Pressure Switch Schematic

THE COMPARISON STAGE

The comparison stage is the “heart” of the pressure switch design. This stage converts the analog voltage output to a digital output, as dictated by the comparator's threshold. The comparison stage has a few design issues which must be addressed:

- The threshold for which the output switches must be programmable. The threshold is easily set by dividing the supply voltage with resistors R_7 and R_{TH} . In [Figure 1](#), the threshold is set at 2.5 V for $R_7 = R_{\text{TH}} = 10 \text{ k}\Omega$.

- A method for providing an appropriate amount of hysteresis should be available. Hysteresis prevents multiple transitions from occurring when slow varying signal inputs oscillate about the threshold. The hysteresis can be set by applying positive feedback. The amount of hysteresis is determined by the value of the feedback resistor, R_H (refer to equations in the following section).
- It is ideal for the comparator's logic level output to swing from one supply rail to the other. In practice, this is not possible. Thus, the goal is to swing as high and low as possible for a given set of supplies. This offers the greatest

difference between logic states and will avoid having a microcontroller read the switch level as being in an indeterminate state.

- In order to be compatible with CMOS circuitry and to avoid microcontroller timing delay errors, the comparator must switch sufficiently fast.
- By using two comparators, a window comparator may be implemented. The window comparator may be used to monitor when the applied pressure is within a set range. By adjusting the input thresholds, the window width can be customized for a given application. As with the single threshold design, positive feedback can be used to provide hysteresis for both switching points. The window comparator and the other comparator circuits will be explained in the following section.

EXAMPLE COMPARATOR CIRCUITS

Several comparator circuits were built and evaluated. Comparator stages using the LM311 comparator, LM358 Op-Amp (with and without an output transistor stage), and LM339 were examined. Each comparator was evaluated on output voltage levels (dynamic range), transition speed, and the relative component count required for the complete pressure switch design. This comparison is tabulated in Table 2.

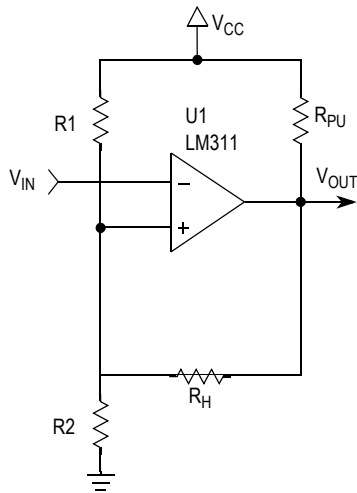

Figure 2. LM311 Comparator Circuit Schematic

LM311 USED IN A COMPARATOR CIRCUIT

The LM311 chip is designed specifically for use as a comparator and thus has short delay times, high slew rate, and an open collector output. A pull-up resistor at the output is all that is needed to obtain a rail-to-rail output. Additionally, the LM311 is a reverse logic circuit; that is, for an input lower than the reference voltage, the output is high. Likewise, when the input voltage is higher than the reference voltage, the output is low. Figure 2 shows a schematic of the LM311 stage with threshold setting resistor divider, hysteresis resistor, and the open-collector pull-up resistor. Table 2 shows the comparator's performance. Based on its performance, this circuit can be used in many types of applications, including interface to microprocessors.

The amount of hysteresis can be calculated by the following equations:

$$V_{REF} = \frac{R_2}{R_1 + R_2} V_{CC}$$

neglecting the effect of R_H

$$V_{REFH} = \frac{R_1 R_2 + R_2 R_H}{R_1 R_2 + R_1 R_H + R_2 R_H} V_{CC}$$

$$V_{REFL} = \frac{R_2 R_H}{R_1 R_2 + R_1 R_H + R_2 R_H} V_{CC}$$

$$\text{HYSTERESIS} = V_{REFH} - V_{REFL}$$

when the normal state is below V_{REF} or

$$\text{HYSTERESIS} = V_{REF} - V_{REFH}$$

when the normal state is above V_{REF} .

Table 2. Comparator Circuits Performance Characteristics

Characteristics	LM311	LM358	LM358 w/Trans.	Unit
Switching Speeds	—	—	—	—
Rise Time	1.40	5.58	2.20	μs
Fall Time	0.04	6.28	1.30	μs
Output Levels	—	—	—	—
V_{OH}	4.91	3.64	5.00	V
V_{OL}	61.1	38.0	66.0	mV
Circuit Logic Type	NEGATIVE	NEGATIVE	POSITIVE	—

The initial calculation for V_{REF} will be slightly in error due to neglecting the effect of R_H . To establish a precise value for

V_{REF} (including R_H in the circuit), recompute $R1$ taking into account that V_{REF} depends on $R1$, $R2$, and R_H . It turns out that when the normal state is below V_{REF} , R_H is in parallel with $R1$:

$$V_{REF} = \frac{R2}{R1 \parallel R_H + R2} V_{CC}$$

(Which is identical to the equation for V_{REFH})

Alternately, when the normal state is above V_{REF} , R_H is in parallel with $R2$:

$$V_{REF} = \frac{R2 \parallel R_H}{R1 + R2 \parallel R_H} V_{CC}$$

(Which is identical to the equation for V_{REFL})

These two additional equations for V_{REF} can be used to calculate a more precise value for V_{REF} .

The user should be aware that V_{REF} , V_{REFH} and V_{REFL} are chosen for each application, depending on the desired switching point and hysteresis values. Also, the user must specify which range (either above or below the reference voltage) is the desired normal state (see Figure 3). Referring to Figure 3, if the normal state is below the reference voltage then V_{REFL} (V_{REFH} is only used to calculate a more precise value for V_{REF} as explained above) is below V_{REF} by the desired amount of hysteresis (use V_{REFL} to calculate R_H). Alternately, if the normal state is above the reference voltage, then V_{REFH} (V_{REFL} is only used to calculate a more precise value for V_{REF}) is above V_{REF} by the desired amount of hysteresis (use V_{REFH} to calculate R_H).

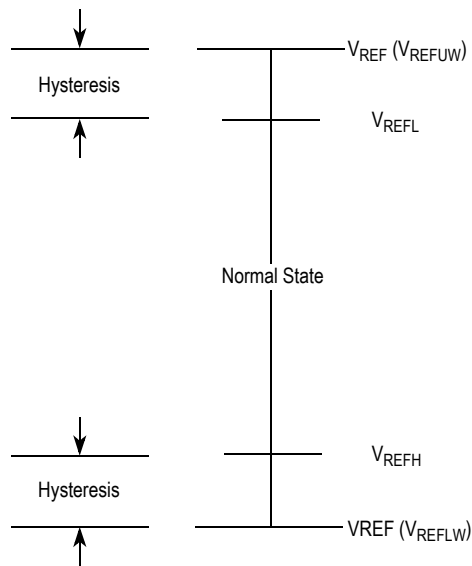

Figure 3. Setting the Reference Voltages

LM358 OP AMP USED IN A COMPARATOR CIRCUIT

Figure 4 shows the schematic for the LM358 op amp comparator stage, and Table 2 shows its performance. Since the LM358 is an operational amplifier, it does not have the fast slew-rate of a comparator IC nor the open collector output. Comparing the LM358 and the LM311 (Table 2), the LM311 is better for logic/switching applications since its output nearly

extends from rail to rail and has a sufficiently high switching speed. The LM358 will perform well in applications where the switching speed and logic-state levels are not critical (LED output, etc.). The design of the LM358 comparator is accomplished by using the same equations and procedure presented for the LM311. This circuit is also reverse logic.

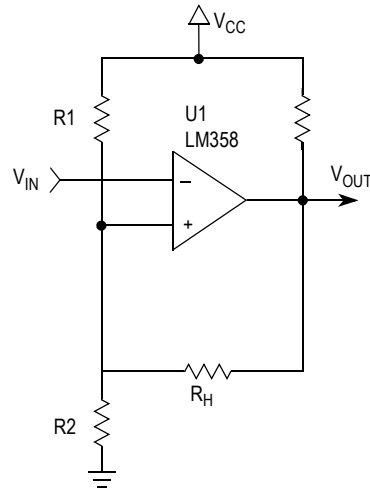

Figure 4. LM358 Comparator Circuit Schematic

LM358 OP AMP WITH A TRANSISTOR OUTPUT STAGE USED IN A COMPARATOR CIRCUIT

The LM358 with a transistor output stage is shown in Figure 5. This circuit has similar performance to the LM311 comparator: its output reaches the upper rail and its switching speed is comparable to the LM311's. This enhanced performance does, however, require an additional transistor and base resistor. Referring to Figure 1, note that this comparator topology was chosen for the pressure switch design. The LM324 is a quad op amp that has equivalent amplifier characteristics to the LM358.

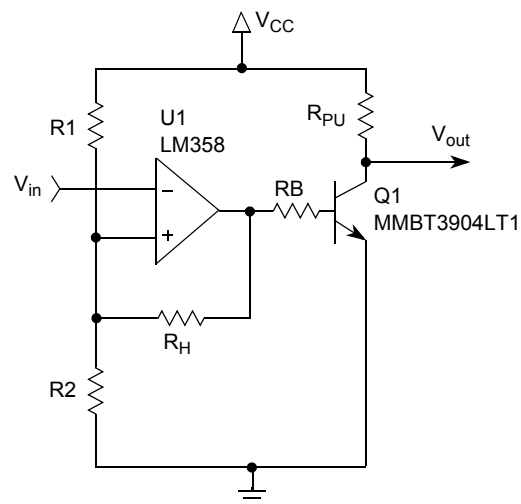

Figure 5. LM358 with a Transistor Output Stage Comparator Circuit Schematic

Like the other two circuits, this comparator circuit can be designed with the same equations and procedure. The values for R_B and R_{PU} are chosen to give a 5:1 ratio in Q1's collector current to its base current, in order to insure that Q1 is well-saturated (V_{OUT} can pull down very close to ground when Q1 is on). Once the 5:1 ratio is chosen, the actual resistance values determine the desired switching speed for turning Q1 on and off. Also, R_{PU} limits the collector current to be within the maximum specification for the given transistor (see example values in Figure 1). Unlike the other two circuits, this circuit is positive logic due to the additional inversion created at the output transistor stage.

LM339 USED IN A WINDOW COMPARATOR CIRCUIT

Using two voltage references to detect when the input is within a certain range is another possibility for the pressure switch design. The window comparator's schematic is shown in Figure 6. The LM339 is a quad comparator IC (it has open collector outputs), and its performance will be similar to that of the LM311.

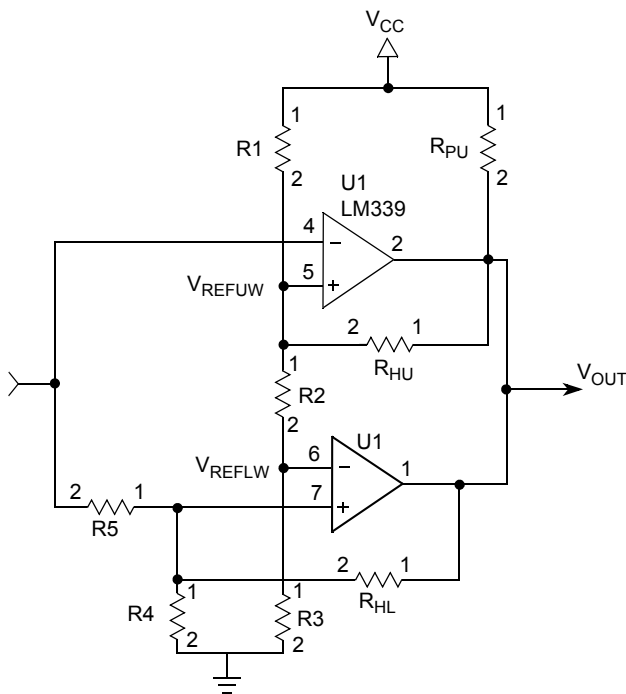

Figure 6. LM339 Window Comparator Circuit Schematic

Obtaining the correct amount of hysteresis and the input reference voltages is slightly different than with the other circuits. The following equations are used to calculate the hysteresis and reference voltages. Referring to Figure 3, V_{REFUW} is the upper window reference voltage and V_{REFLW} is the lower window reference voltage. Remember that reference voltage and threshold voltage are interchangeable terms.

For the upper window threshold:

Choose the value for V_{REFUW} and R1 (e.g., 10 k Ω). Then, by voltage division, calculate the total resistance of the

combination of R2 and R3 (named R23 for identification) to obtain the desired value for V_{REFUW} , neglecting the effect of R_{HU} :

$$V_{REFUW} = \frac{R23}{R1 + R23} V_{CC}$$

The amount of hysteresis can be calculated by the following equation:

$$V_{REFUW} = \frac{R23R_{HU}}{R1R23 + R1R_{HU} + R23R_{HU}} V_{CC}$$

Notice the upper window reference voltage, V_{REFUW} , is now equal to its V_{REFL} value, since at this moment, the input voltage is above the normal state.

$$\text{HYSTERESIS} = V_{REFUW} - V_{REFL}$$

where V_{REFL} is chosen to give the desired amount of hysteresis for the application.

The initial calculation for V_{REFUW} will be slightly in error due to neglecting the effect of R_{HU} . To establish a precise value for V_{REFUW} (including R_{HU} in the circuit), recompute R1 taking into account that V_{REFUW} depends on R2 and R3 and the parallel combination of R1 and R_{HU} . This more precise value is calculated with the following equation:

$$V_{REFUW} = \frac{R23}{R1 \parallel R_{HU} + R23} V_{CC}$$

for the lower window threshold choose the value for V_{REFLW} :

$$\text{Set } V_{REFLW} = \frac{R3}{R1 \parallel R_{HU} + R2 + R3} V_{CC}$$

where $R2 + R3 = R23$ from above calculation.

To calculate the hysteresis resistor:

The input to the lower comparator is one half V_{IN} (since $R4 = R5$) when in the normal state. When V_{REFLW} is above one half of V_{IN} (i.e., the input voltage has fallen below the window), R_{HL} parallels R4, thus loading down V_{IN} . The resulting input to the comparator can be referred to as V_{INL} (a lower input voltage). To summarize, when the input is within the window, the output is high and only R4 is connected to ground from the comparator's positive terminal. This establishes one half of V_{IN} to be compared with V_{REFLW} . When the input voltage is below V_{REFLW} , the output is low, and R_{HL} is effectively in parallel with R4. By voltage division, less of the input voltage at V_{IN} is required to make the noninverting input exceed V_{REFLW} .

Therefore, the following equations are established:

$$\text{HYSTERESIS} = V_{\text{REFLW}} - V_{\text{INL}}$$

Choose $R_4 = R_5$ to simplify the design.

$$R_{\text{HL}} = \frac{R_4 R_5 (V_{\text{REFLW}} - V_{\text{INL}} - V_{\text{CC}})}{(R_4 + R_5)(V_{\text{INL}} - V_{\text{REFLW}})} V_{\text{CC}}$$

NOTE:

As explained above, because the input voltage is divided in half by R_4 and R_5 , all calculations are done relative to the one half value of V_{in} . Therefore, for a hysteresis of 200 mV (relative to V_{in}), the above equations must use one half this hysteresis value (100 mV). Also, if a V_{REFLW} value of 2.0 V is desired (relative to V_{in}), then 1.0 V for its value should be used in the above equations. The value for V_{INL} should be scaled by one half also.

The window comparator design can also be designed using operational amplifiers and the same equations as for the LM339 comparator circuit. For the best performance, however, a transistor output stage should be included in the design.

TEST/CALIBRATION PROCEDURE

1. Before testing the circuit, the user-defined values for R_{TH} , R_{H} and R_{OFF} should be calculated for the desired application.

The sensor offset voltage is set by

$$V_{\text{OFF}} = \frac{V_{\text{OFF}}}{R_1 + R_{\text{OFF}}} V_{\text{CC}}$$

Then, the amplified sensor voltage corresponding to a given pressure is calculated by:

$$V_{\text{SENSOR}} = 201 \times 0.0002 \times \text{APPLIED PRESSURE} + V_{\text{OFF}}$$

where 201 is the gain, 0.0002 is in units of V/kPa and APPLIED PRESSURE is in kPa.

The threshold voltage, V_{TH} , at which the output changes state is calculated by determining V_{SENSOR} at the pressure that causes this change of state:

$$V_{\text{TH}} = V_{\text{SENSOR}} (@ \text{ pressure threshold}) = \frac{R_{\text{TH}}}{R_7 + R_{\text{TH}}} V_{\text{CC}}$$

If hysteresis is desired, refer to the LM311 *Used in a Comparator* section to determine R_{H} .

2. To test this design, connect a +5 volt supply between pins 3 and 4 of the connector CN1.
3. Connect a volt meter to pins 1 and 4 of CN1 to measure the output voltage and amplified sensor voltage, respectively.
4. Connect an additional volt meter to the V_{TH} probe point to verify the threshold voltage.
5. Turn on the supply voltage.
6. With no pressure applied, check to see that V_{off} is correct by measuring the voltage at the output of the gain stage (the volt meter connected to Pin 4 of CN1). If desired, V_{off} can be fine tuned by using a potentiometer for R_{off} .
7. Check to see that the volt meter monitoring V_{TH} displays the desired voltage for the output to change states. Use a potentiometer for R_{TH} to fine tune V_{TH} , if desired.
8. Apply pressure to the sensor. Monitor the sensor's output via the volt meter connected to pin 4 of CN1. The output will switch from low to high when this pressure sensor voltage reaches or exceeds the threshold voltage.
9. If hysteresis is used, with the output high (pressure sensor voltage greater than the threshold voltage), check to see if V_{TH} has dropped by the amount of hysteresis desired.

A potentiometer can be used for R_{H} to fine tune the amount of hysteresis.

CONCLUSION

The pressure switch design uses a comparator to create a logic level output by comparing the pressure sensor output voltage and a user-defined reference voltage. The flexibility of this minimal component, high performance design makes it compatible with many different applications. The design presented here uses an op amp with a transistor output stage, yielding excellent logic-level outputs and output transition speeds for many applications. Finally, several other comparison stage designs, including a window comparator, are evaluated and compared for overall performance.



NOTES

How to Reach Us:

Home Page:

www.freescale.com

Web Support:

<http://www.freescale.com/support>

USA/Europe or Locations Not Listed:

Freescale Semiconductor, Inc.
Technical Information Center, EL516
2100 East Elliot Road
Tempe, Arizona 85284
+1-800-521-6274 or +1-480-768-2130
www.freescale.com/support

Europe, Middle East, and Africa:

Freescale Halbleiter Deutschland GmbH
Technical Information Center
Schatzbogen 7
81829 Muenchen, Germany
+44 1296 380 456 (English)
+46 8 52200080 (English)
+49 89 92103 559 (German)
+33 1 69 35 48 48 (French)
www.freescale.com/support

Japan:

Freescale Semiconductor Japan Ltd.
Headquarters
ARCO Tower 15F
1-8-1, Shimo-Meguro, Meguro-ku,
Tokyo 153-0064
Japan
0120 191014 or +81 3 5437 9125
support.japan@freescale.com

Asia/Pacific:

Freescale Semiconductor Hong Kong Ltd.
Technical Information Center
2 Dai King Street
Tai Po Industrial Estate
Tai Po, N.T., Hong Kong
+800 2666 8080
support.asia@freescale.com

For Literature Requests Only:

Freescale Semiconductor Literature Distribution Center
P.O. Box 5405
Denver, Colorado 80217
1-800-441-2447 or 303-675-2140
Fax: 303-675-2150
LDCForFreescaleSemiconductor@hibbertgroup.com

Information in this document is provided solely to enable system and software implementers to use Freescale Semiconductor products. There are no express or implied copyright licenses granted hereunder to design or fabricate any integrated circuits or integrated circuits based on the information in this document.

Freescale Semiconductor reserves the right to make changes without further notice to any products herein. Freescale Semiconductor makes no warranty, representation or guarantee regarding the suitability of its products for any particular purpose, nor does Freescale Semiconductor assume any liability arising out of the application or use of any product or circuit, and specifically disclaims any and all liability, including without limitation consequential or incidental damages. "Typical" parameters that may be provided in Freescale Semiconductor data sheets and/or specifications can and do vary in different applications and actual performance may vary over time. All operating parameters, including "Typicals", must be validated for each customer application by customer's technical experts. Freescale Semiconductor does not convey any license under its patent rights nor the rights of others. Freescale Semiconductor products are not designed, intended, or authorized for use as components in systems intended for surgical implant into the body, or other applications intended to support or sustain life, or for any other application in which the failure of the Freescale Semiconductor product could create a situation where personal injury or death may occur. Should Buyer purchase or use Freescale Semiconductor products for any such unintended or unauthorized application, Buyer shall indemnify and hold Freescale Semiconductor and its officers, employees, subsidiaries, affiliates, and distributors harmless against all claims, costs, damages, and expenses, and reasonable attorney fees arising out of, directly or indirectly, any claim of personal injury or death associated with such unintended or unauthorized use, even if such claim alleges that Freescale Semiconductor was negligent regarding the design or manufacture of the part.

Freescale™ and the Freescale logo are trademarks of Freescale Semiconductor, Inc. All other product or service names are the property of their respective owners.

© Freescale Semiconductor, Inc. 2006. All rights reserved.

