

Compound Coefficient Pressure Sensor PSPICE Models

by: Warren Schultz

INTRODUCTION

PSPICE models for Uncompensated, MPX2000 series, and MPX5000 series pressure sensors are presented here. These models use compound coefficients to improve modeling of temperature dependent behavior. The discussion begins with an overview of how the models are structured, and is followed by an explanation of compound coefficients. The emphasis is on how to use these models to estimate sensor performance. They can be found electronically on a disk included in ASB200 Sensor Development Controller kits.

MODEL STRUCTURE

Models for all three sensors series share a common structure. They are complete models set up to run as is. To obtain output voltage versus pressure, it is only necessary to run the model and display V(2,4) or V(1,0). V(2,4) gives the output voltage for Uncompensated and MPX2000 series sensors. V(1,0) applies to MPX5000 sensors. In both cases, V(2,4) and V(1,0) correspond to the pin numbers where output voltage would be, if probed on an actual part.

These models are divided into five sections to facilitate ease of use. They are:

- [Input Parameters](#)
- [Linear to Compound Conversion](#)
- [Model Coefficients](#)
- [Circuit](#)
- [Stimulus](#)

Each of these sections is described in the following discussion.

INPUT PARAMETERS

This section contains input parameters that describe measurable sensor characteristics. Inputs such as full scale pressure (FSP), full scale span (FSS) offset voltage (VOFFSET), and temperature coefficient of offset voltage (TCOS) are made here. Characteristics that are specific to the transducer, such as bridge impedance (RBRIDGE), temperature coefficient of bridge resistance (TCRB), and temperature coefficient of span (TCSP) are also listed here.

Parameters such as VOFFSET that set an output value for the sensor are used to calculate resistance values that

produce those outputs. For example, if you input 100 mV of offset voltage and a 10 $\mu\text{V}/\text{degree}$ temperature coefficient of offset voltage, the model will calculate the bridge resistance values necessary to produce 100 mV of offset voltage and a 10 $\mu\text{V}/\text{degree}$ temperature coefficient.

In the MPX2000 and MPX5000 models, temperature coefficient of span (TCSP) is handled differently than the other parameters. The non-linear behavior of span over temperature is calculated from the interaction of the transducer's temperature coefficient of span (TCSP), the transducer's temperature coefficient of resistance (TCRB), and the effects of inserting fixed resistance, RTCSPAN, in series with the bridge. The result is a temperature coefficient of span that closely resembles the real thing, but is not directly controlled by the user.

LINEAR TO COMPOUND CONVERSION

The compound coefficients used in these models are from equations of the form:

$$(1) R(\text{Temp}) = R_{25}(1) \text{TCR}(\text{Temp} - 25)$$

where R_{25} is resistance at 25 degrees Celsius, TCR is temperature coefficient of resistance, Temp is an abbreviation for Temperature in degrees Celsius, and $R(\text{Temp})$ is the function resistance versus temperature.

The TCR (temperature coefficient of resistance) in equation (1) is a different number than a temperature coefficient that is stated in linear terms. The three statements in this section convert linear coefficients to the compound values that the models need. This conversion is based upon a 100 degree difference between the two points at which the linear coefficients have been measured.

MODEL COEFFICIENTS

In this section most of the calculation is performed. Values for the transducer bridge resistors are determined from pressure, temperature, offset, temperature coefficient of offset, span, temperature coefficient of span, and temperature coefficient of resistance inputs. A series of parameter statements are used, as much as is practical, to do calculations that will fit in an 80 character line without wraparounds. These calculations use PSPICE's

PARAMETER function, making the models specific to PSPICE. Parameters are described as:

- KP - Pressure constant; translates pressure into a bridge resistance multiplier
- KO - Offset constant; offset component of bridge resistance
- DT - Delta temperature; Temperature *25 degrees Celsius
- KTCO - Temperature coefficient of offset constant; translates temperature coefficient of offset into bridge resistance
- TCR - Temperature coefficient of bridge resistance; shaped by a Table that accounts for cold temperature non-linearity's
- TCR2 - Temperature coefficient of contact resistance; shaped by a Table that accounts for cold temperature non-linearity's
- TCS - Temperature coefficient of Span; shaped by a Table that accounts for cold temperature non-linearity's
- RPH - Bridge Resistance (RS1 and RS3) modified by pressure and temperature
- ROH - Offset Component of Bridge Resistors RS1 and RS3
- RPL - Bridge Resistance (RS2 and RS4) modified by pressure and temperature
- ROL - Offset Component of Bridge Resistors RS2 and RS4
- KB - Bias Constant; adjusts KP for bias voltage effects of span compensation network (MPX2000 and MPX5000 series sensors)

- KBT - Bias Constant; adjusts KO for bias voltage effects of span compensation network (MPX2000 and MPX5000 series sensors)
- GAIN - Instrumentation amplifier gain; differential gain (MPX5000 series)
- ROFF - Offset resistance; determines value of RS13 (MPX5000 series)

After these calculations are made, the final bridge resistance calculation is performed in the circuit section. The value for bridge resistors RS1 and RS3 is $RPH + ROH$. Bridge resistors RS2 and RS4 are equal to $RPL - ROL$.

CIRCUIT

Three circuits are used to model the three sensor families, one each for the Uncompensated series, MPX2000 series, and MPX5000 series sensors. Schematics that are derived from the circuit netlists are shown in Figure 1, Figure 2, and Figure 3. They are discussed beginning with the Uncompensated series, which is the least complex.

Uncompensated Series

The Uncompensated Series sensors (MPX10, MPX50, and MPX100) are modeled as Wheatstone bridges. In the configuration that is shown in Figure 1, resistors RS2 and RS4 decrease in value as pressure is applied. Similarly, RS1 and RS3 increase in value as pressure is applied. Resistors RS5 and RS7 are contact resistors. They represent real physical resistors that are used to make contact to the bridge. Resistors RS6 and RS8 are included to satisfy PSPICE's requirement for no floating nodes. That's it. The netlist in this model is quite simple. The hard part is calculating the values for RS1, RS2, RS3, and RS4.

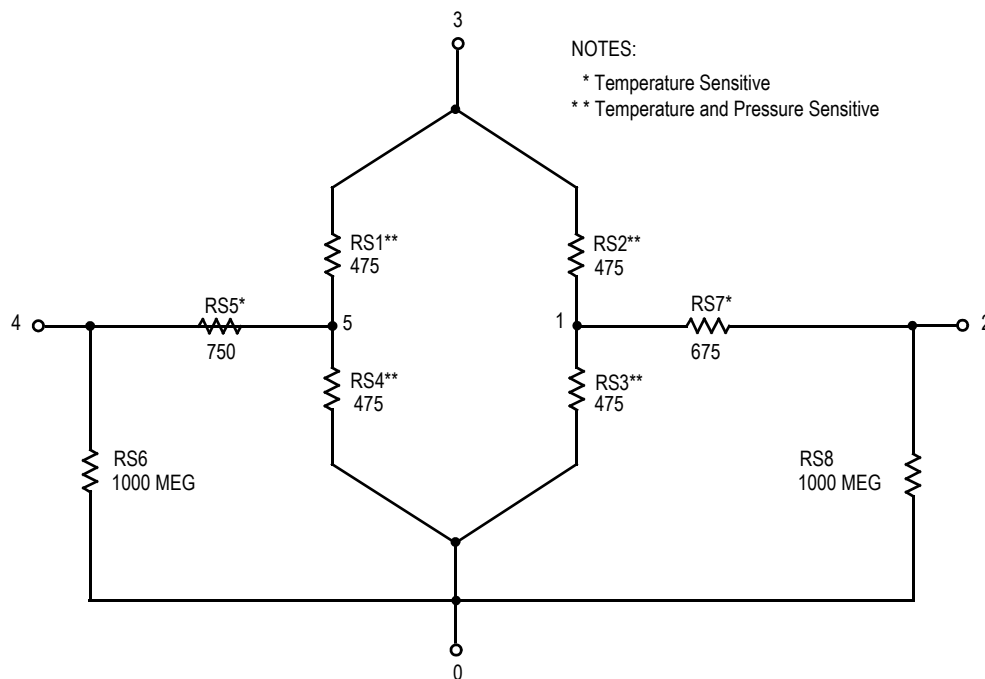

Figure 1. MPX10 and 100 PSPICE Compound Coefficient Model

MPX2000 Series:

The MPX2000 Series sensors (MPX2010, MPX2050, MPX2100, and MPX2200) add span compensation and trim resistors to the Uncompensated model. These resistors are shown in Figure 2 as RS9, RS11, and RS10. The temperature coefficient of resistance (TCR) for the bridge resistors works against fixed resistors RS9 and RS11 to produce a bias to the bridge that increases with temperature. This increasing bias compensates for the temperature coefficient of span, which is negative.

Resistor RS12 is also added to the Uncompensated model. It represents additional impedance that is associated with the MPX2000 series sensors' offset trim network. Offset performance is modeled behaviorally. Inputs for offset (VOFFSET) and temperature coefficient of offset (TCOS) are translated into bridge resistance values that produce the specified performance. This behavioral approach was chosen in order to make it easy to plug in different values for VOFFSET and TCOS.

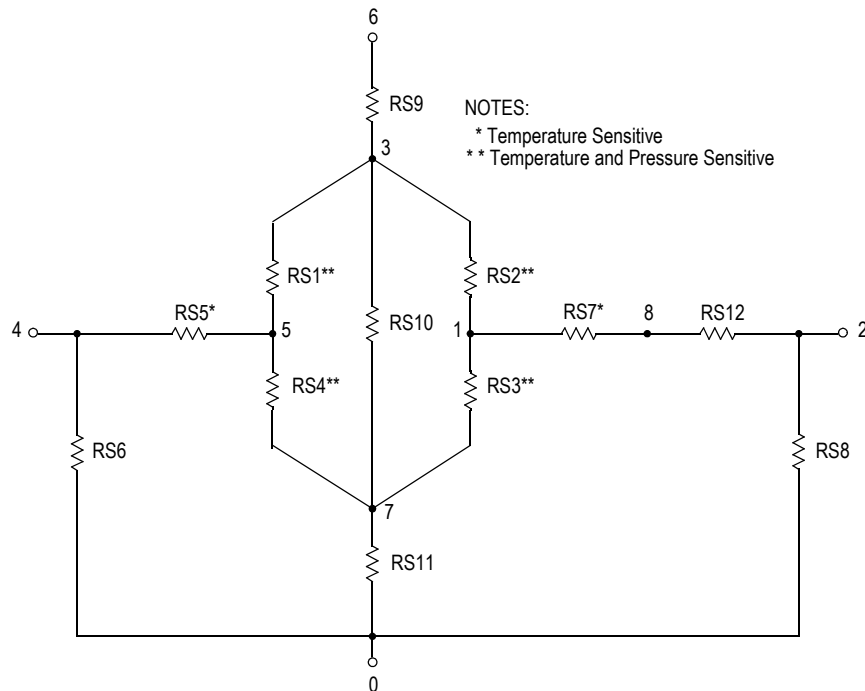
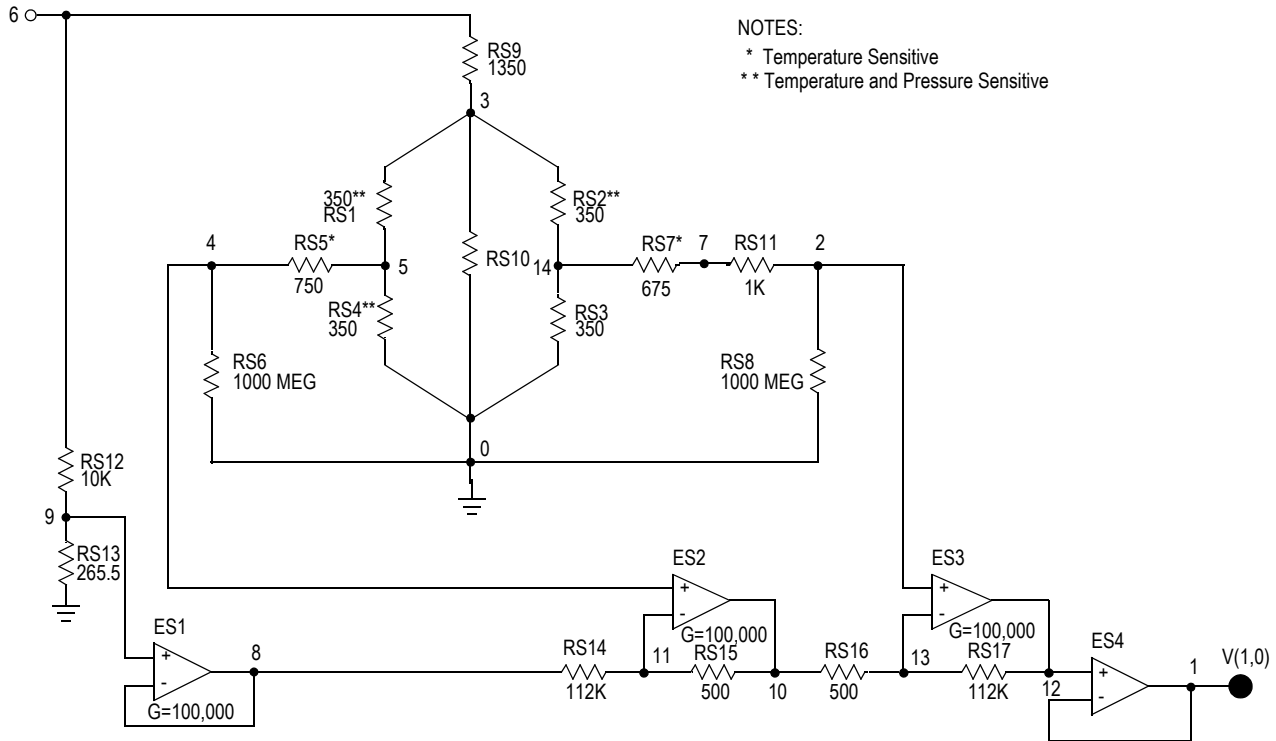

Figure 2. MPX2000 Series PSPICE Compound Coefficient Model

MPX5000 Series

The MPX5000 Series sensors (MPX5010, MPX5050, MPX5100, MPX5700, and MPX5999) add an instrumentation amplifier to the MPX2000 series model. This amplifier is shown in Figure 3. It consists of operational amplifiers ES1, ES2, ES3, and ES4. Amplifiers ES1, ES2 and ES3 are

modeled as voltage controlled voltage sources with gains of 100,000. Offset voltage, input bias current effects, etc. are taken into account with the values that are used to determine offset voltage and temperature coefficient of the sensor bridge. Amplifier ES4 models saturation voltage. Its output follows the output of ES3 with saturation limits at 75 millivolts and 4.9 volts.



NOTES:
 * Temperature Sensitive
 ** Temperature and Pressure Sensitive

Figure 3. MPX Series PSPICE Compound Coefficient Model

STIMULUS

The last section of these models is labeled STIMULUS. Bias voltage, pressure, and temperature are applied here. Nominal bias voltage (VCC) is 3.0 volts for Uncompensated sensors, 10.0 volts for MPX2000 sensors, and 5.0 volts for MPX5000 sensors. Pressure is selected on the second line. It is effective when the asterisk (*) on line 4 is removed to command a temperature sweep. Line 3 calls for a sweep of pressure and temperature. An asterisk (*) placed in front of Line 3 allows the temperature sweep on line four to be selected.

COMPOUND COEFFICIENTS

Applying temperature coefficients to variables such as resistance is an essential part of modeling. The linear approach, that is usually used, is based upon the assumption that changes are small, and can be modeled with a linear approximation. Using temperature coefficient of resistance as (TCR) as an example, the linear expression takes the form:

$$(2) R(\text{Temp}) = R_{25}(1) \text{TCR}(\text{Temp} - 25)$$

Provided that the TCR in equation (2) is 100 parts per million per degree Celsius or less this approach works quite well. With sensor TCR's of several thousand parts per million per degree Celsius, however, the small change assumption does not hold. To accurately model changes of this magnitude, the mathematical expression has to describe a physical process where a unit change in temperature produces a constant percentage change in resistance. For

example, a 1% per degree TCR applied to a 1 K Ohm resistor should add 10 ohms to the resistor's value going from 25 to 26 degrees. At 70 degrees, where the resistor has increased to 2006 Ohms, going from 70 to 71 degrees should add 20.06 Ohms to its value. The error in the linear expression comes from that fact that it adds 10 ohms to the resistor's value at all temperatures.

A physical process whereby a unit change in temperature produces a constant percentage change in resistance is easily modeled by borrowing an expression from finance. Compound interest is a direct analog of temperature coefficients. With compound interest, a unit change in time produces a constant percentage change in the value of a financial instrument. It can be described by the expression:

$$(3) \text{Future Value} = \text{Present Value} (1 + i)^n$$

where i is the interest rate and n is the number of periods. Substituting R_{25} for Present Value, $R(\text{Temp})$ for Future Value, TCR for i , and $(\text{Temp} - 25)$ for n yields:

$$(4) R(\text{Temp}) = R_{25}(1 + \text{TCR})^{(\text{Temp} - 25)}$$

Equation (4) works quite well, provided that TCR is constant over temperature. When modeling semiconductor resistors, it is also necessary to account for variable TCR's. At cold, the TCR for p type resistors changes with temperature. These changes are modeled using TABLE functions that have three values for TCR. Results of this modeling technique versus actual measurements and a linear model are summarized in Table 1.

Table 1. Actual versus Modeled R(Temp)

Temp	Measured R(Temp)	Compound Model	Linear Model
*40	406	406	372
*25	418	418	395
0	445	445	434
25	474	474	474
50	509	508	513
75	545	545	552
100	585	584	592
125	627	626	632
150	671	671	671

In Table 1, 25 and 150 degree Celsius data points were used to determine both linear and compound temperature

coefficients. Therefore, measured values, linear model values and compound model values all match at these two temperatures. At other temperatures, the linear model exhibits errors that are significant when modeling piezoresistive pressure sensors. The compound model, however, tracks with measured values to within 1 Ohm out of 500 Ohms.

EXAMPLES

Two examples of what the model outputs look like are shown in Figure 4 and Figure 5. Figure 4 shows a sweep of pressure versus output voltage (V_{OUT}) at 0, 25, and 85 degrees Celsius, for an MPX2010 sensor. It has the expected 0 to 25 mV output voltage, given a 0 to 10 kPa pressure input. At these three temperatures, compensation is sufficiently good that all three plots look like the same straight line.

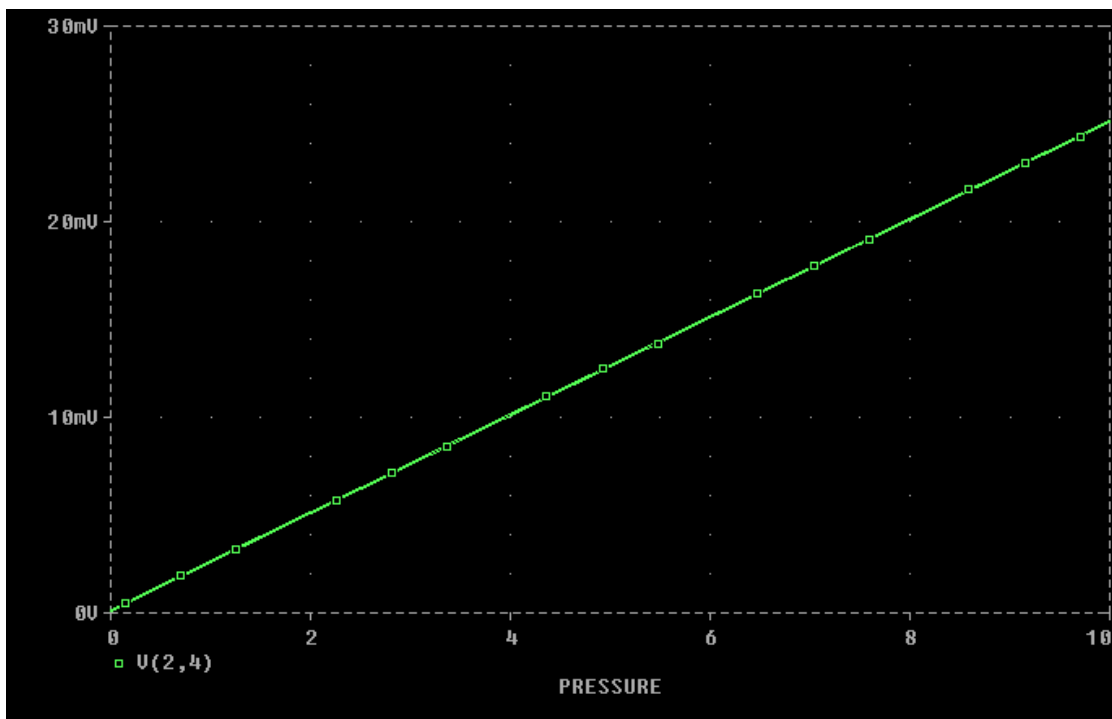

Figure 4. MPX2010 V_{OUT} versus Pressure and Temperature

To produce the plot in Figure 4, the stimulus section is set up as follows, and V(2,4) is probed.

STIMULUS

```
VCC 6 0 DC=10; DC BIAS FROM PIN 3 TO PIN 1
.PARAM PRESSURE=0; INPUT PRESSURE (kPa)
.DC PARAM PRESSURE 0_Kpa 10_Kpa 0.5_Kpa TEMP
LIST 0 25 85
*.DC PARAM TEMP -40 125 5
*
```

This is the default configuration with which the model is shipped. To change to a sweep of zero pressure voltage versus temperature, an asterisk is placed on line 3 and removed from line 4. The stimulus section then looks as follows:

STIMULUS

```
VCC 6 0 DC=10; DC BIAS FROM PIN 3 TO PIN 1
.PARAM PRESSURE=0; INPUT PRESSURE (kPa)
*.DC PARAM PRESSURE 0_Kpa 10_Kpa 0.5_Kpa TEMP
LIST 0 25 85
.DC PARAM TEMP -40 125 5
*
```

Again, V(2,4) is probed. The resulting output appears in Figure 5.

This plot shows offset versus temperature performance that is typical of MPX2000 series sensors. From -40 to +85 degrees Celsius, offset compensation is quite good. Above 85 degrees there is a hook in this curve, that is an important attribute of the sensor's performance.

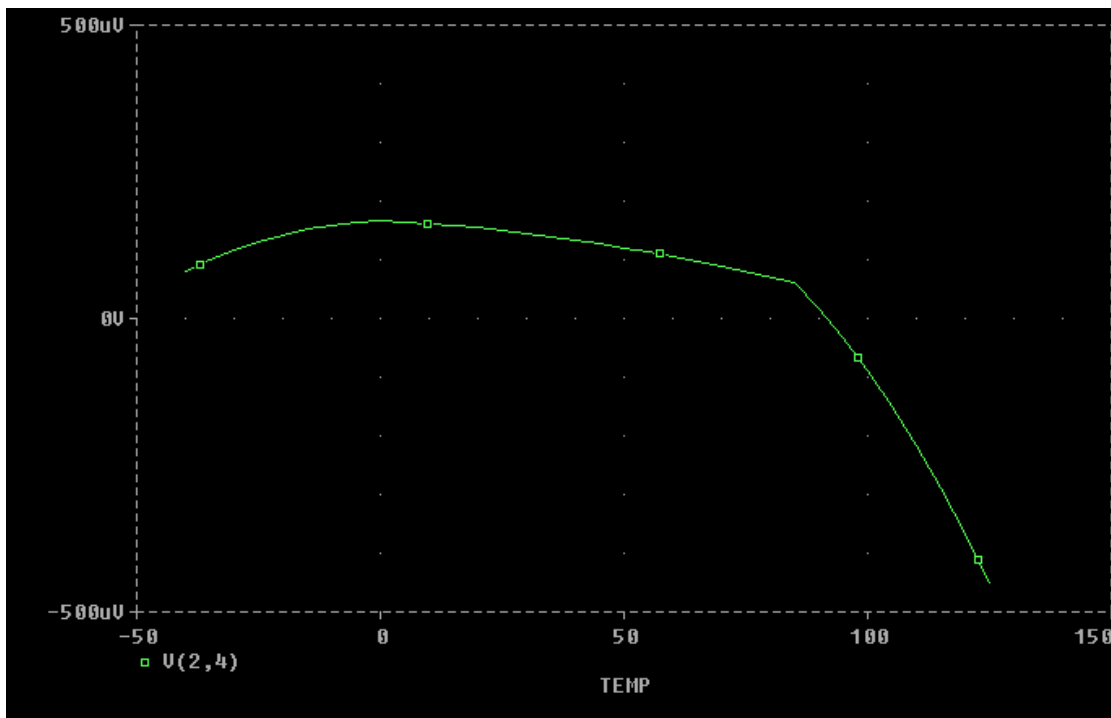

Figure 5. MPX2010 Offset versus Temperature

CONCLUSION

PSPICE models for Uncompensated, MPX2000 series, and MPX5000 series pressure sensors are available for estimating sensor performance. These models make use of the compounding concept that is used in finance to calculate compound interest. The resulting compound temperature coefficients do a better job than linear methods of modeling temperature dependent behavior. These models make extensive use of PSPICE's PARAMETER statement, and are, therefore, specific to PSPICE. They are intended as references for determining typical sensor performance, and are structured for easy entry of alternate assumptions.

DISCLAIMERS

Macromodels, simulation models, or other models provided by Freescale Semiconductor, Inc., directly or indirectly, are not warranted by Freescale as fully representing all of the specifications and operating characteristics of the semiconductor product to which the model relates. Moreover, these models are furnished on an "as is" basis without support or warranty of any kind, either expressed or implied, regarding the use thereof and Freescale specifically disclaims all implied warranties of merchantability and fitness of the models for any purpose. Freescale does not assume any liability arising out of the application or use of the models including infringement of patents and copyrights nor does Freescale convey any license under its patents and copyrights or the rights of others. Freescale reserves the right to make changes without notice to any model.

Although macromodels can be a useful tool in evaluating device performance in various applications, they cannot

model exact device performance under all conditions, nor are they intended to replace breadboarding for final verification.

Freescale reserves the right to make changes without further notice to any products herein. Freescale makes no warranty, representation or guarantee regarding the suitability of its products for any particular purpose, nor does Freescale assume any liability arising out of the application or use of any product or circuit, and specifically disclaims any and all liability, including without limitation consequential or incidental damages. "Typical" parameters can and do vary in different applications. All operating parameters, including "Typicals" must be validated for each customer application by customer's technical experts. Freescale does not convey any license under its patent rights nor the rights of others. Freescale products are not designed, intended, or authorized for use as components in systems intended for surgical implant into the body, or other applications intended to support or sustain life, or for any other application in which the failure of the Freescale product could create a situation where personal injury or death may occur. Should Buyer purchase or use Freescale products for any such unintended or unauthorized application, Buyer shall indemnify and hold Freescale and its officers, employees, subsidiaries, affiliates, and distributors harmless against all claims, costs, damages, and expenses, and reasonable attorney fees arising out of, directly or indirectly, any claim of personal injury or death associated with such unintended or unauthorized use, even if such claim alleges that Freescale was negligent regarding the design or manufacture of the part. Freescale and (Freescale logo symbol) are registered trademarks of Freescale Semiconductor, Inc. Freescale is an Equal Opportunity/Affirmative Action Employer.

PSPICE is a registered trademark of MicroSim Corporation. If you have any questions or suggestions, please contact:

Freescale Semiconductor, Inc.
Semiconductor Products Sector
Sensor Products Division
5005 East McDowell Road
Phoenix, AZ 85008
(602) 244-4556

How to Reach Us:

Home Page:

www.freescale.com

E-mail:

support@freescale.com

USA/Europe or Locations Not Listed:

Freescale Semiconductor
Technical Information Center, CH370
1300 N. Alma School Road
Chandler, Arizona 85224
+1-800-521-6274 or +1-480-768-2130
support@freescale.com

Europe, Middle East, and Africa:

Freescale Halbleiter Deutschland GmbH
Technical Information Center
Schatzbogen 7
81829 Muenchen, Germany
+44 1296 380 456 (English)
+46 8 52200080 (English)
+49 89 92103 559 (German)
+33 1 69 35 48 48 (French)
support@freescale.com

Japan:

Freescale Semiconductor Japan Ltd.
Headquarters
ARCO Tower 15F
1-8-1, Shimo-Meguro, Meguro-ku,
Tokyo 153-0064
Japan
0120 191014 or +81 3 5437 9125
support.japan@freescale.com

Asia/Pacific:

Freescale Semiconductor Hong Kong Ltd.
Technical Information Center
2 Dai King Street
Tai Po Industrial Estate
Tai Po, N.T., Hong Kong
+800 2666 8080
support.asia@freescale.com

For Literature Requests Only:

Freescale Semiconductor Literature Distribution Center
P.O. Box 5405
Denver, Colorado 80217
1-800-441-2447 or 303-675-2140
Fax: 303-675-2150
LDCForFreescaleSemiconductor@hibbertgroup.com

Information in this document is provided solely to enable system and software implementers to use Freescale Semiconductor products. There are no express or implied copyright licenses granted hereunder to design or fabricate any integrated circuits or integrated circuits based on the information in this document.

Freescale Semiconductor reserves the right to make changes without further notice to any products herein. Freescale Semiconductor makes no warranty, representation or guarantee regarding the suitability of its products for any particular purpose, nor does Freescale Semiconductor assume any liability arising out of the application or use of any product or circuit, and specifically disclaims any and all liability, including without limitation consequential or incidental damages. "Typical" parameters that may be provided in Freescale Semiconductor data sheets and/or specifications can and do vary in different applications and actual performance may vary over time. All operating parameters, including "Typicals", must be validated for each customer application by customer's technical experts. Freescale Semiconductor does not convey any license under its patent rights nor the rights of others. Freescale Semiconductor products are not designed, intended, or authorized for use as components in systems intended for surgical implant into the body, or other applications intended to support or sustain life, or for any other application in which the failure of the Freescale Semiconductor product could create a situation where personal injury or death may occur. Should Buyer purchase or use Freescale Semiconductor products for any such unintended or unauthorized application, Buyer shall indemnify and hold Freescale Semiconductor and its officers, employees, subsidiaries, affiliates, and distributors harmless against all claims, costs, damages, and expenses, and reasonable attorney fees arising out of, directly or indirectly, any claim of personal injury or death associated with such unintended or unauthorized use, even if such claim alleges that Freescale Semiconductor was negligent regarding the design or manufacture of the part.

Freescale™ and the Freescale logo are trademarks of Freescale Semiconductor, Inc. All other product or service names are the property of their respective owners.

© Freescale Semiconductor, Inc. 2005. All rights reserved.

