

1) Amplifier's gain is set to 1,100 at the frequency of 50 or 60Hz.

Figure 1 shows the detail of amplifier.

2) Sensor is set in the test fixture as shown in Figure 2.

3) AC current of 100mA (rms) is applied to the copper wire.

4) Amplifier's output voltage is read with oscilloscope while Sensor is slowly moved along the guide rail.

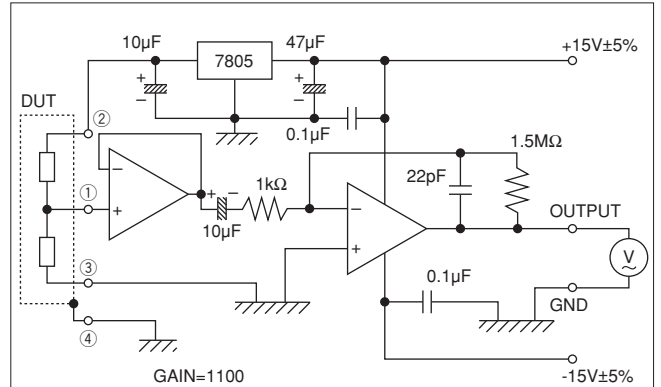

Figure 1. Amplifier For Output Voltage Measurement

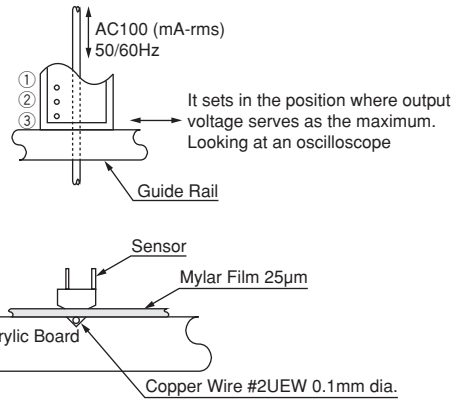

Figure 2. Test Fixture For Output Voltage Measurement