



# MMA8450Q Design Checklist and Board Mounting Guidelines

by: Kimberly Tuck  
Applications Engineer

## 1.0 Introduction

This document is intended to assist customers with the design-in of the MMA8450Q and/or other family derivatives. This document points out the similarities of the Pinout for the MMA845xQ family, giving recommendations for a layout that will work with any family member. The focus of this document is on the MMA8450Q. A separate document will be available for other family members. There are a few small differences between the MMA8450Q and the other family members which are important to note.

This document provides the following information:

- Pinout description, options and recommendations for every pin of the MMA8450Q
- Pin differences and recommendations for the MMA8451, MMA8452, MMA8453
- Application diagrams to assist in designing a layout compatible with all family members
- Guidelines for how best to mount the MMA845xQ to a Printed Circuit Board (PCB)
- Recommended connections for I<sup>2</sup>C communication

### 1.1 Key Words

Accelerometer, Board Mounting, Solder Paste, Printed Circuit Board (PCB), I<sup>2</sup>C Communication, Pull-up Resistor, Pull-down Resistor, Sensor, I/O pins, Non Solder Mask Defined, Solder Mask, Land Pattern, Stencil, Halogen Free Package, RoHS Compliant, Level translator, QFN, Bypass Capacitor

### TABLE OF CONTENTS

<b>1.0 Introduction</b> .....	<b>1</b>
1.1 Key Words .....	1
1.2 Summary .....	2
<b>2.0 MMA8450Q Consumer 3-axis Accelerometer 3 x 3 x 1 mm</b> .....	<b>2</b>
2.1 Key Features of the MMA8450Q .....	2
2.2 Two (2) Programmable Interrupt Pins for 8 Interrupt Sources .....	2
2.3 Application Notes for the MMA8450Q .....	3
<b>3.0 Pin Connections to the MMA8450Q 3-axis Accelerometer</b> .....	<b>3</b>
<b>4.0 Board Layout</b> .....	<b>6</b>
4.1 Power Supply Decoupling .....	6
4.2 Level Translators .....	6
4.3 I/O Pins .....	6
4.4 Sensor Placement .....	7
<b>5.0 I<sup>2</sup>C Communication</b> .....	<b>7</b>
<b>6.0 Offset Calibration</b> .....	<b>7</b>
<b>7.0 Mounting Guidelines for the Quad Flat No Lead (QFN) Package</b> .....	<b>7</b>
7.1 Overview of Soldering Considerations .....	7
7.2 Halogen Content .....	7
7.3 PCB Mounting Recommendations .....	8
<b>PACKAGE DIMENSIONS</b> .....	<b>9</b>

## 1.2 Summary

- A. Power supply decoupling recommendation is given.
- B. The Pinout of the MMA8450Q is compatible with the MMA8451, MMA8452 and MMA8453 with a few differences to note. This is shown in the schematics in this document with recommendations for laying out a board that is compatible for any family member of the MMA845XQ.
- C. Board layout recommendations are given with an example showing the MMA8450Q Sensor Toolbox Demo Board LFSTBEB8450.
- D. Mounting guidelines and package specifications are given to assist in customer board mount.

## 2.0 MMA8450Q Consumer 3-axis Accelerometer 3 x 3 x 1 mm

The MMA8450Q has a selectable dynamic range of  $\pm 2g$ ,  $\pm 4g$  and  $\pm 8g$  with sensitivities of 1024 counts/g, 512 counts/g and 256 counts/g respectively. The device offers either 8-bit or 12-bit XYZ output data for algorithm development. The chip shot and pinout are shown in [Figure 1](#).

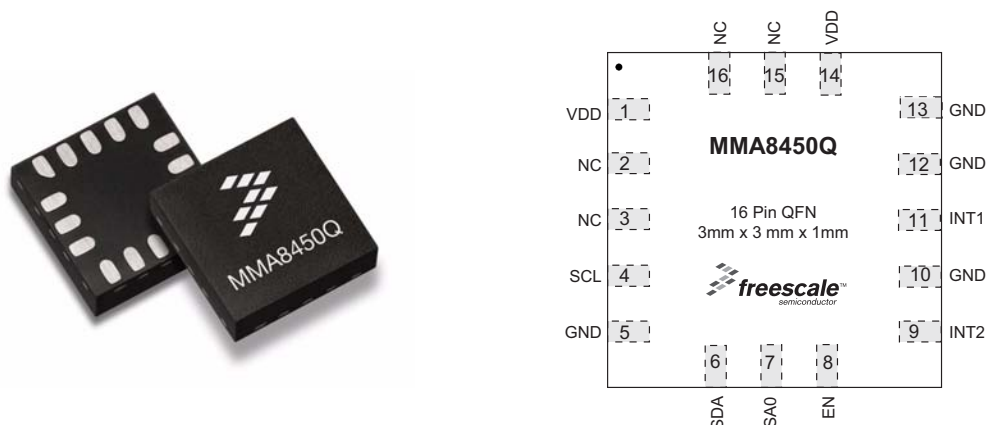

Figure 1. MMA8450Q Consumer 3-axis Accelerometer 3 x 3 x 1 mm

### 2.1 Key Features of the MMA8450Q

1. Shutdown Mode: Typical  $< 1 \mu A$ , Standby Mode  $3 \mu A$
2. Low Power Mode current consumption ranges from  $27 \mu A$  (1.56 - 50 Hz) to  $120 \mu A$  (400 Hz)
3. Normal Mode current consumption ranges from  $42 \mu A$  (1.56 - 50 Hz) to  $225 \mu A$  (400 Hz)
4.  $I^2C$  digital output interface (operates up to 400 kHz Fast Mode)
5. 12-bit and 8-bit data output, 8-bit high pass filtered data output
6. Post Board Mount Offset  $< \pm 50$  mg typical
7. Self Test X, Y and Z axes

### 2.2 Two (2) Programmable Interrupt Pins for 8 Interrupt Sources

1. Embedded 4 channels of Motion detection
  - a. Frefall or Motion detection: 2 channels
  - b. Tap detection: 1 channel
  - c. Transient detection: 1 channel
2. Embedded orientation (Portrait/Landscape) detection with hysteresis compensation
3. Embedded automatic ODR change for auto-wake-up and return-to-sleep
4. Embedded 32 sample FIFO
5. Data Ready Interrupt

## 2.3 Application Notes for the MMA8450Q

The following is a list of Freescale Application Notes written for the MMA8450Q:

- **AN3915**, *Embedded Orientation Detection Using the MMA8450Q*
- **AN3916**, *Offset Calibration of the MMA8450Q*
- **AN3917**, *Motion and Freefall Detection Using the MMA8450Q*
- **AN3918**, *High Pass Filtered Data and Transient Detection Using the MMA8450Q*
- **AN3919**, *MMA8450Q Single/Double and Directional Tap Detection*
- **AN3920**, *Using the 32 Sample First In First Out (FIFO) in the MMA8450Q*
- **AN3921**, *Low Power Modes and Auto-Wake/Sleep Using the MMA8450Q*
- **AN3922**, *Data Manipulation and Basic Settings of the MMA8450Q*
- **AN3923**, *MMA8450Q Design Checklist and Board Mounting Guidelines*

## 3.0 Pin Connections to the MMA8450Q 3-axis Accelerometer

[Table 1](#) describes each pin of the MMA8450Q and the recommended connections. [Figure 2](#) is the recommended applications schematic for the MMA8450Q.

**Table 1. Connections with Descriptions and Recommendations MMA8450Q**

Pin #	Pin Name	Description	Status	Recommendation
1	VDD	Power	Input	Connect to Pin 14 (VDD)
2	NC or GND	Internal Use Only	NC	Leave unconnected, or Ground
3	NC or GND	Internal Use Only	NC	Leave unconnected, or Ground
4	SCL	Serial Clock for I <sup>2</sup> C Communication	Open Drain	Pull-up Resistor (4.7 kΩ) required on I <sup>2</sup> C bus
5	GND	Ground	Input	Connect to Ground
6	SDA	Serial Data	Open Drain	Pull-up Resistor (4.7 kΩ) required on I <sup>2</sup> C bus
7	SAO	Address Pin	Input	Connect to Ground for I <sup>2</sup> C Address \$1C. Connect to VDD for I <sup>2</sup> C Address \$1D
8	EN	Enable Pin	Input	Connect as an input from the MCU to be able to toggle between Shutdown and Standby. VDD will enable the device.
9	INT2	Interrupt Pin	Output	Connect to MCU interrupt or KBI
10	GND	Internal Use - Ground	Input	Connect to Ground
11	INT1	Interrupt Pin	Output	Connect to MCU interrupt or KBI
12	GND	Ground	Input	Connect to Ground
13	GND	Ground	Input	Connect to Ground
14	VDD	Power	Input	Connect to Pin 1 (VDD)
15	NC	Not Internally Connected	Input	Leave unconnected, but can connect to VDD or GND
16	NC	Not Internally Connected	Input	Leave unconnected, but can connect to VDD or GND

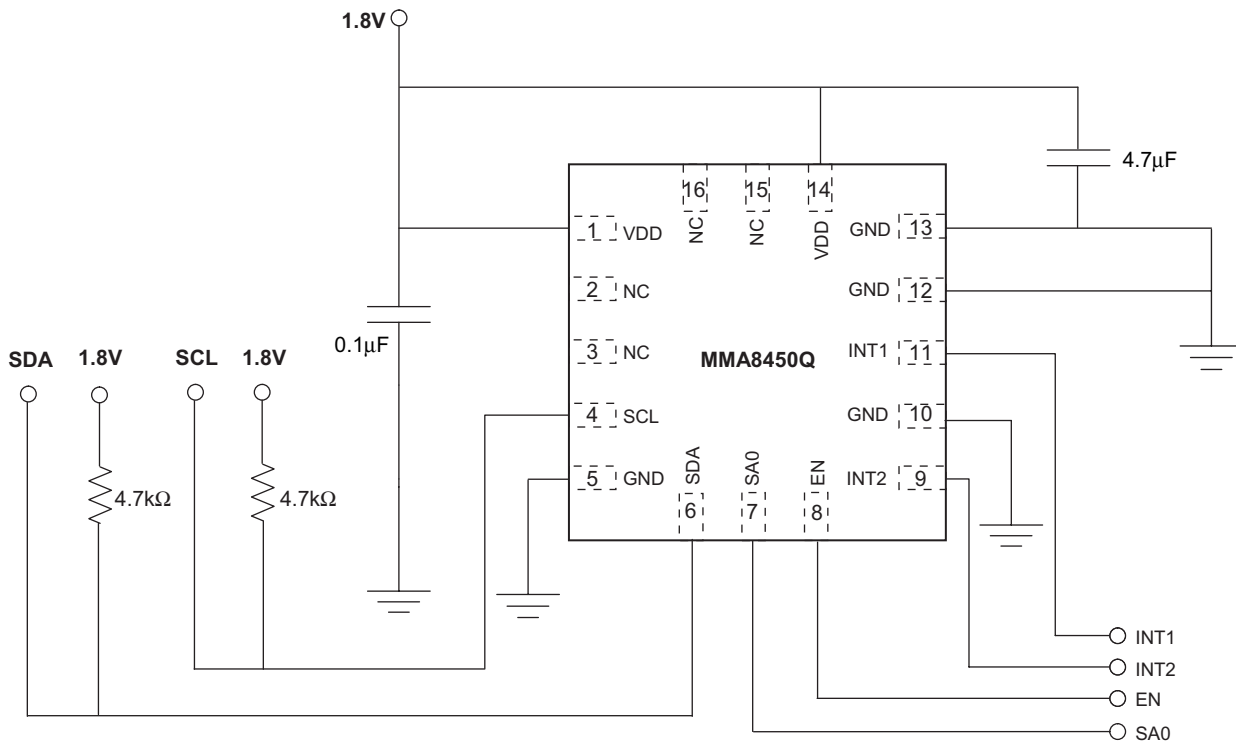

**Figure 2. MMA8450Q Recommended Connections**

**Note:** The MMA8450Q has other family members with the same Pinout. There are a few modifications to consider which apply to the other family members only. It may be wise to design the layout so that it is easy to configure for any device. [Figure 3](#) is the schematic for the MMA8451Q, MMA8452Q and MMA8453Q.

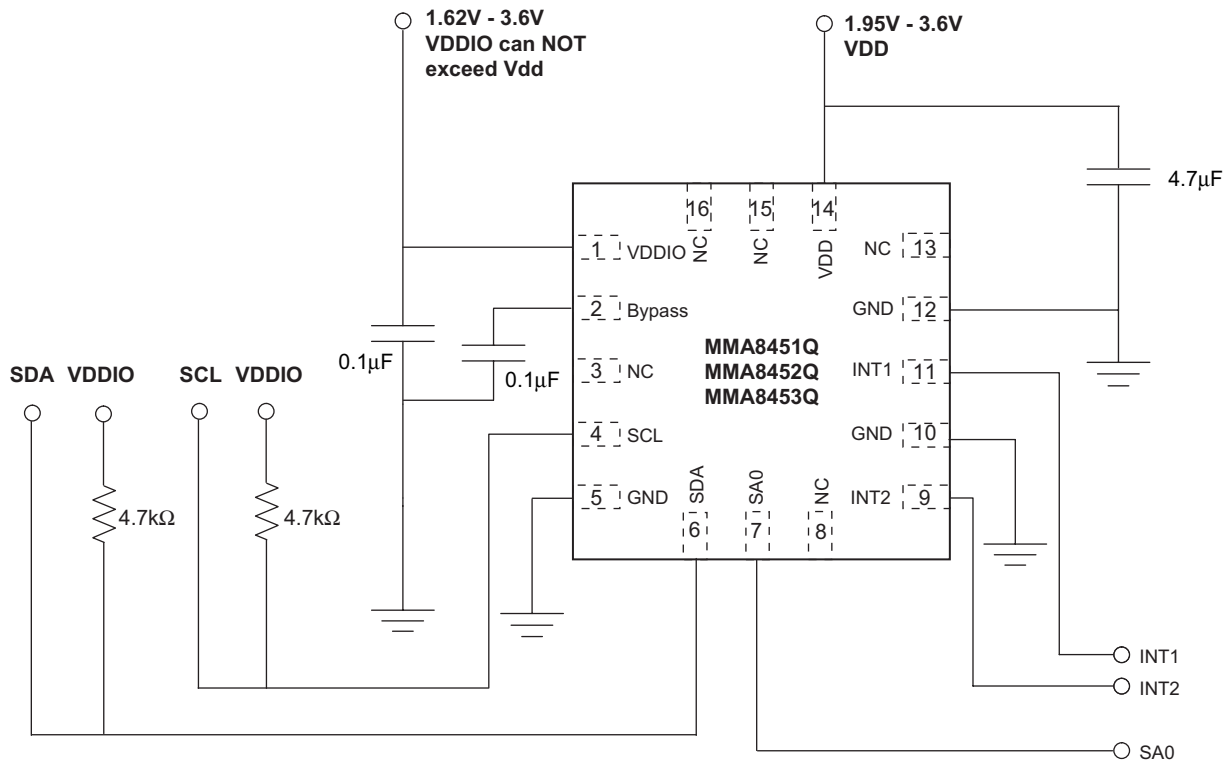

**Figure 3. Recommended Connections for MMA8451Q, MMA8452Q, MMA8453Q**

By adding a 0Ω resistor between VDD and then another 0Ω resistor between VDD and VDDIO the layout can be configured to be used with any of the MMA845xQ family members as shown in Figure 4.

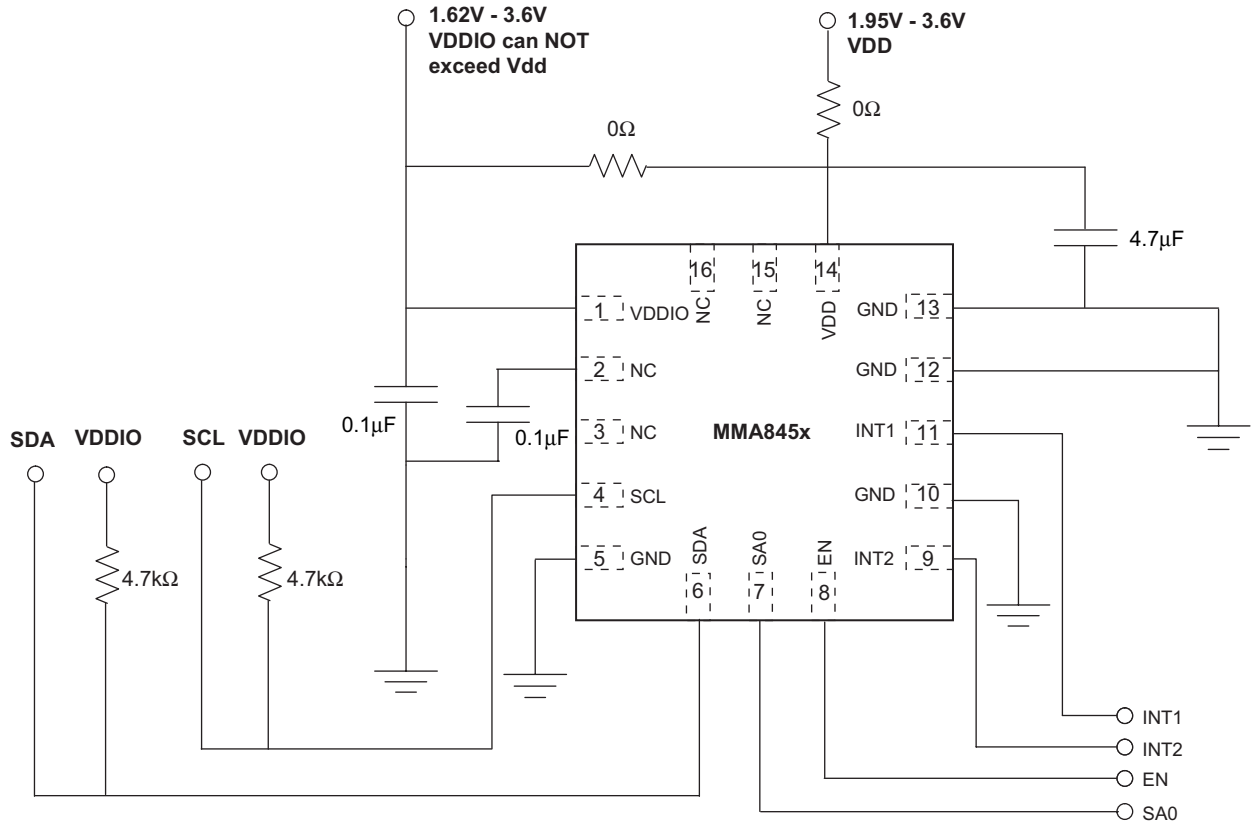

Figure 4. Recommended Connections for MMA845xQ

Table 2. Pinout Comparison of MMA845xQ Family Members

Pin#	MMA8450Q	Recommendation MMA8450Q	MMA8451, MMA8452, MMA8453	Recommendation MMA8451, MMA8452, MMA8453
1	VDD	Connect to Pin 14 (1.8 V)	VDDIO	1.62 V - 3.6 V
2	NC or GND	NC or Bypass Cap to Gnd	Bypass	Bypass Cap to Ground
3	NC	Leave unconnected	NC	Leave unconnected
4	SCL	Pull-up Resistor (4.7 kΩ) required on I <sup>2</sup> C bus	SCL	Pull-up Resistor (4.7 kΩ) required on I <sup>2</sup> C bus
5	GND	Connect to Ground (10,12,13)	GND	Connect to Ground (10,12,13)
6	SDA	Pull-up Resistor (4.7 kΩ) required on I <sup>2</sup> C bus	SDA	Pull-up Resistor (4.7 kΩ) required on I <sup>2</sup> C bus
7	SA0	Connect to Ground for I <sup>2</sup> C Address \$1C. Connect to VDD for I <sup>2</sup> C Address \$1D.	SA0	Connect to Ground for I <sup>2</sup> C Address \$1C. Connect to VDD for I <sup>2</sup> C Address \$1D
8	EN	Connect to MCU	NC	Leave unconnected or connect to MCU
9	INT2	Connect to MCU interrupt or KBI	INT2	Connect to MCU interrupt or KBI
10	GND	Connect to Ground	GND	Connect to Ground
11	INT1	Connect to MCU interrupt or KBI	INT1	Connect to MCU interrupt or KBI
12	GND	Connect to Ground	GND	Connect to Ground
13	GND	Connect to Ground	NC	Connect to Ground or leave NC
14	VDD	Connect to Pin 1 (1.8 V)	AVDD	Analog Input 1.95 V - 3.6 V
15	NC	Leave unconnected, but can connect to VDD or GND	NC	Leave unconnected, but can connect to VDD or GND
16	NC	Leave unconnected, but can connect to VDD or GND	NC	Leave unconnected, but can connect to VDD or GND

## 4.0 Board Layout

The following are some important considerations for board layout of the MMA845xQ accelerometer to ensure the best performance. The MMA8450Q has a very tight voltage input tolerance which may call for an extra voltage regulator for some systems. Level translators may be required if the MCU/processor is operating at a higher voltage. Bypass capacitors are recommended on the input voltage pins to ensure a clean signal to the sensor for optimal noise performance. Figure 5, is Freescale's MMA8450Q Sensor Toolbox Demo Board. This is a four (4) layer board. The board was designed to be able to access every pin on both the MCU and on the accelerometer for quick debug. The board has 32Mbit Flash which can be used for data logging and to perform algorithm analysis. The board has an LED and a switch for general purpose functions and a resistor, "R3", that can be cut to measure current drain from the accelerometer. This board was designed as small as possible so that it would be non invasive when mounted on other boards for different applications. The board can plug into an interface board to the PC or to a battery board. The flat back of the board is great for mounting the board with the battery pack onto moving objects to log data. The flat back also allows the board to be easily mounted to other designs. All the accelerometer pins are accessible through the board, bypassing the MC9S08QE8 microcontroller, if another external processor/MCU will be used. For use of the board as a demo board please visit [www.freescale.com/sensortoolbox](http://www.freescale.com/sensortoolbox). The part number of the board is LFSTBEB8450. The software is available on the web site at the link.

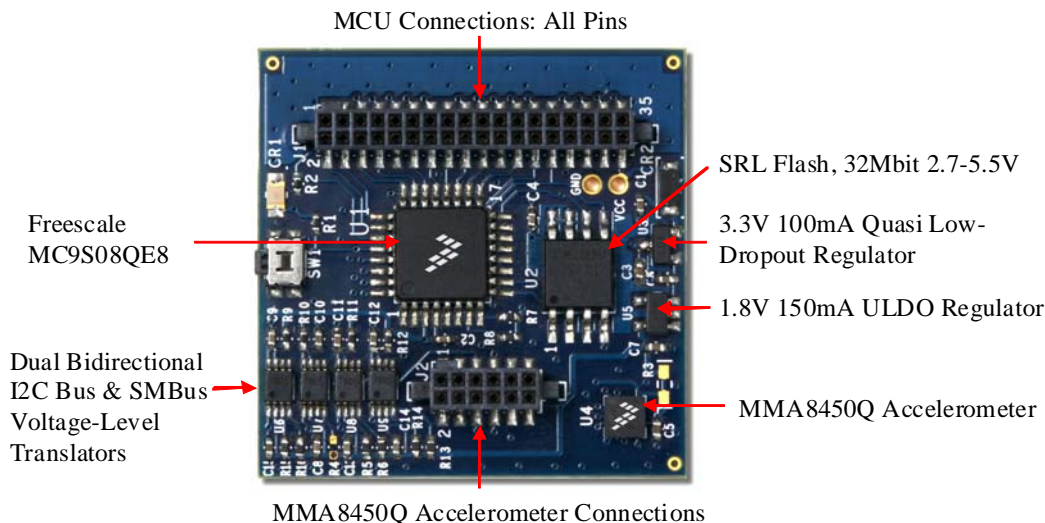

Figure 5. MMA8450Q Sensor Tool Box Demo Board

### 4.1 Power Supply Decoupling

A 4.7  $\mu\text{F}$  capacitor is recommended to filter noise in case the input supply is noisy, and a 0.1  $\mu\text{F}$  bypass capacitor is recommended to filter out high frequency noise. Place these capacitors as close to the part as possible. The caps should be placed between power and ground.

### 4.2 Level Translators

As shown in the Sensor Toolbox Demo board level translators are required since the MCU is operating at 3.3 V and the operating voltage of the MMA8450Q is 1.8 V. The SCL, SDA, SA0, EN, INT1 and INT2 signals will shift through the level translator when communicating back and for to the MCU.

### 4.3 I/O Pins

Pin 7 (SA0: Address Pin), Pin 8 (EN: Enable Pin), Pin 9 (INT2), Pin 11 (INT1), Pin 6 (SDA), Pin 4 (SCL) should all use pull-up/down resistors to ensure they maintain the state of the pin for use by applications. The interrupt pins can be configured to be push-pull or open drain and can be either active high or active low. If a pull-up resistor is used on the interrupt pins with the open drain setting, then the MMA8450Q should be configured to Active Low. If a pull-down resistor is used, then the interrupt pin should be configured to be Active High. This is done in Register 0x3A. Bit 0 (MMA8450Q) which sets the configuration of the interrupt pins to be open drain or push pull and Bit 1 sets the polarity, either Active High or Active Low.

## 4.4 Sensor Placement

Sensor placement is very important and is often overlooked. The MEMS sensor inside the package is very sensitive to stresses. Small deflections inside the MEMS sensor on the order of 10 nm correspond to a change in acceleration of 1g. Care must be taken to ensure that the package is not stressed by holes or components on the PCB placed too closely to the accelerometer. It is important to place the sensor where it is NOT vulnerable to be pushed or otherwise affected directly by the user's hands. Also avoid bending the PCB containing the sensor as the PCB stress is transferred to the accelerometer. Temperature can also be an issue. It is good to avoid placing the sensor near components that may have large temperature variations, or that are constantly very hot as this will affect the offset of the sensor. For optimal motion detection, place the sensor away from the center of the device. This will ensure better acceleration readings and make them more significant to detect smaller motions, from a higher moment of inertia than if placed right on the center of movement.

## 5.0 I<sup>2</sup>C Communication

The MMA8450Q I<sup>2</sup>C communication protocol follows the Philips Semiconductors (now NXP Semiconductors) standard. In this interface, only two bus lines are required: a serial data line (SDA) and a serial clock line (SCL). Serial, 8-bit oriented bidirectional data transfers can be made at up to 100 kbit/s in the Standard-mode and up to 400 kbit/s in the fast-mode. These modes are adjustable by changing the clock frequency. The maximum allowable bus capacitance is 400 pF. Both SDA and SCL are bidirectional lines, connected to a positive supply voltage via a pull-up resistor. The recommended value is between 2.2 k $\Omega$  – 4.7k $\Omega$ . The accelerometer is always considered the slave and the MCU is always considered the master.

The benefits of the I<sup>2</sup>C Communication interface is that many ICs can be added to this bus. The only limitation is the bus capacitance. The simple 2-wire serial I<sup>2</sup>C-bus minimizes interconnections so ICs have fewer pins and there are not as many PCB traces, resulting in smaller and less expensive PCBs.

Each device is recognized by a unique address (whether it is a microcontroller, memory or an accelerometer). The MMA8450Q has an extra address bit to allow for two different addresses available using Pin 7 (SA0). When Pin 7 is high, the address is 0x1D. When Pin 7 is low, the address is 0x1C.

<\$1D = 0001 1101 > bit 0 is VDD on Pin 7  
<\$1C = 0001 1100 > bit 0 is GND on Pin 7

## 6.0 Offset Calibration

After the accelerometer has been mounted onto a PCB there may be a small offset shift. The MMA8450Q has excellent 0g offset specs. The typical offset is below  $\pm 50$  mg for all axes. If additional calibration is required to zero out any offset, please refer to Freescale application note, AN3916, "Offset Calibration of the MMA8450Q".

## 7.0 Mounting Guidelines for the Quad Flat No Lead (QFN) Package

Surface mount board layout is a critical portion of the total design. The footprint for the surface mount packages must be the correct size to ensure proper solder connection interface between the board and the package. With the correct footprint, the packages will self-align when subjected to a solder reflow process. It is always recommended to design boards with a solder mask layer to avoid bridging and shorting between solder pads.

These guidelines are for soldering and mounting the Quad Flat No-Lead (QFN) package inertial sensors to printed circuit boards (PCBs). The purpose is to minimize the stress on the package after board mounting. The MMA8450Q digital output accelerometer uses the QFN package platform. This section describes suggested methods of soldering these devices to the PC board for consumer applications. [Pages 9, 10](#) and [11](#) show the package outline drawing.

### 7.1 Overview of Soldering Considerations

Information provided here is based on experiments executed on QFN devices. They do not represent exact conditions present at a customer site. Hence, information herein should be used as guidance only and process and design optimizations are recommended to develop an application specific solution. It should be noted that with the proper PCB footprint and solder stencil designs, the package will self-align during the solder reflow process.

### 7.2 Halogen Content

This package is designed to be Halogen Free, exceeding most industry and customer standards. Halogen Free means that no homogeneous material within the assembly package shall contain chlorine (Cl) in excess of 700 ppm or 0.07% weight/weight or bromine (Br) in excess of 900 ppm or 0.09% weight/weight.

### 7.3 PCB Mounting Recommendations

1. The PCB land should be designed with Non Solder Mask Defined (NSMD) as shown in Figure 6 and Figure 7.
2. No additional via pattern underneath package.
3. PCB land pad is 0.8 mm x 0.3 mm as shown in Figure 6 and Figure 7.
4. Solder mask opening = PCB land pad edge + 0.113 mm larger all around.
5. Stencil opening = PCB land pad -0.015 mm smaller all around = 0.77 mm x 0.27 mm.
6. Stencil thickness is 75  $\mu\text{m}$ .
7. Do not place any components or vias at a distance less than 2 mm from the package land area. This may cause additional package stress if it is too close to the package land area.
8. Signal traces connected to pads are as symmetric as possible. Put dummy traces on NC pads in order to have same length of exposed trace for all pads.
9. Use a standard pick and place process and equipment. Do not use a hand soldering process.
10. It is recommended to use a no clean solder paste.
11. Do not use a screw down or stacking to fix the PCB into an enclosure because this could bend the PCB putting stress on the package.
12. The PCB should be rated for the multiple lead-free reflow condition with max 260°C temperature.
13. No copper traces on top layer of PCB under the package. This will cause planarity issues with board mount.

Freescall QFN sensors are compliant with Restrictions on Hazardous Substances (RoHS), having halide free molding compound (green) and lead-free terminations. These terminations are compatible with tin-lead (Sn-Pb) as well as tin-silver-copper (Sn-Ag-Cu) solder paste soldering processes. Reflow profiles applicable to those processes can be used successfully for soldering the devices.

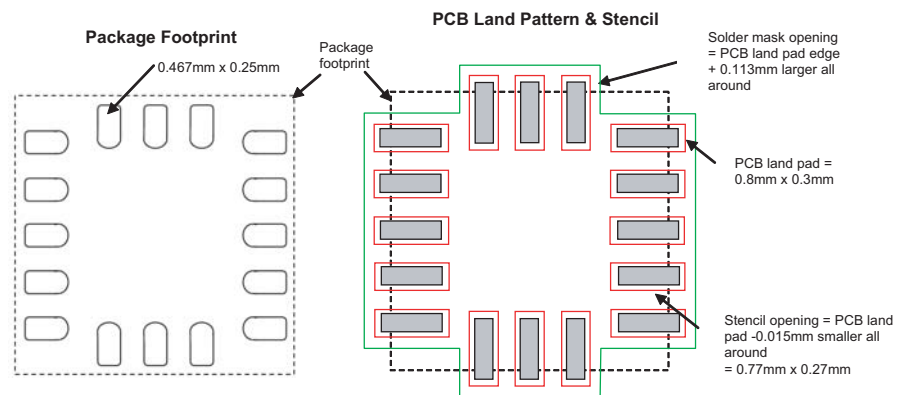

Figure 6. Recommended PCB Land Pad, Solder Mask and Stencil Opening Near Package Footprint

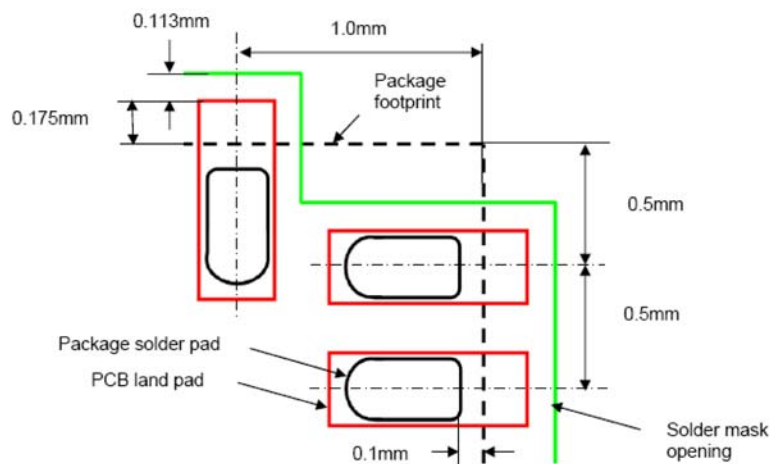
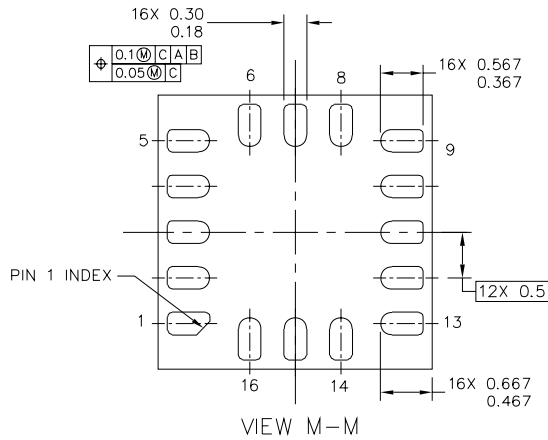
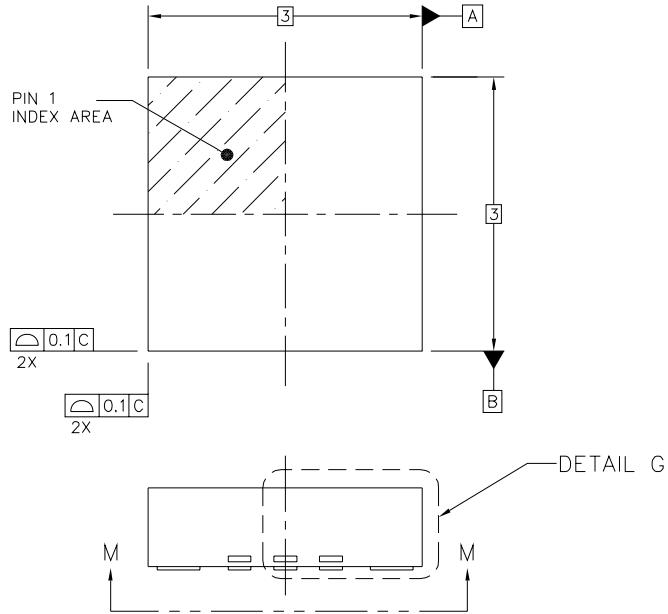

Figure 7. Detailed Dimensions

## PACKAGE DIMENSIONS



© FREESCALE SEMICONDUCTOR, INC. ALL RIGHTS RESERVED.	MECHANICAL OUTLINE	PRINT VERSION NOT TO SCALE	
TITLE: QUAD FLAT NO LEAD COL PACKAGE (QFN-COL) 16 TERMINAL, 0.5 PITCH (3 X 3 X 1.0)	DOCUMENT NO: 98ASA00063D		REV: 0
	CASE NUMBER: 2077-01		26 JAN 2010
	STANDARD: NON JEDEC		

**CASE 2077-01  
ISSUE O  
16-LEAD QFN**

# PACKAGE DIMENSIONS

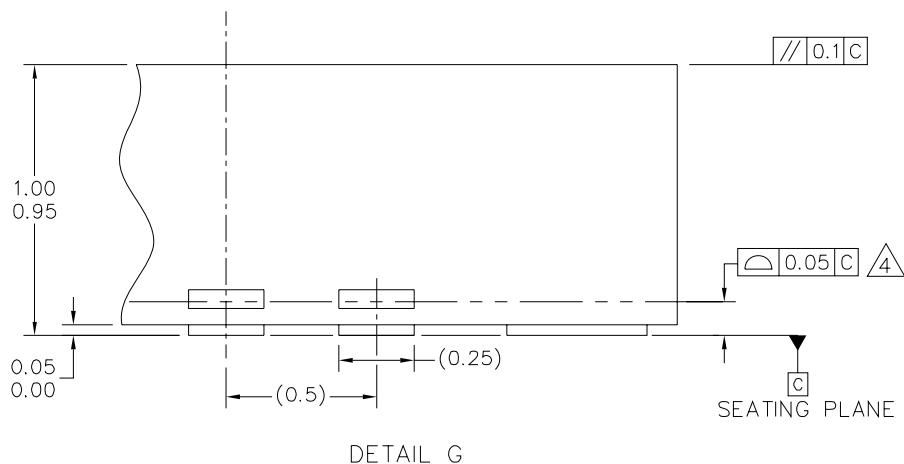

© FREESCALE SEMICONDUCTOR, INC. ALL RIGHTS RESERVED.	MECHANICAL OUTLINE	PRINT VERSION NOT TO SCALE	
TITLE: QUAD FLAT NO LEAD COL PACKAGE (QFN-COL) 16 TERMINAL, 0.5 PITCH (3 X 3 X 1.0)	DOCUMENT NO: 98ASA00063D	REV: 0	
	CASE NUMBER: 2077-01	26 JAN 2010	
	STANDARD: NON JEDEC		

**CASE 2077-01  
ISSUE 0  
16-LEAD Q**

## PACKAGE DIMENSIONS

### NOTES:

1. ALL DIMENSIONS ARE IN MILLIMETERS.
2. INTERPRET DIMENSIONS AND TOLERANCES PER ASME Y14.5M-1994.
3. THIS IS NON JEDEC REGISTERED PACKAGE.
4.  COPLANARITY APPLIES TO ALL LEADS.
5. MIN. METAL GAP SHOULD BE 0.2MM.

© FREESCALE SEMICONDUCTOR, INC. ALL RIGHTS RESERVED.	MECHANICAL OUTLINE	PRINT VERSION NOT TO SCALE	
TITLE: QUAD FLAT NO LEAD COL PACKAGE (QFN-COL) 16 TERMINAL, 0.5 PITCH (3 X 3 X 1.0)	DOCUMENT NO: 98ASA00063D	REV: 0	
	CASE NUMBER: 2077-01	26 JAN 2010	
	STANDARD: NON JEDEC		

**CASE 2077-01  
ISSUE 0  
16-LEAD Q**

**AN3923**

## **How to Reach Us:**

### **Home Page:**

[www.freescale.com](http://www.freescale.com)

### **Web Support:**

<http://www.freescale.com/support>

### **USA/Europe or Locations Not Listed:**

Freescale Semiconductor, Inc.  
Technical Information Center, EL516  
2100 East Elliot Road  
Tempe, Arizona 85284  
1-800-521-6274 or +1-480-768-2130  
[www.freescale.com/support](http://www.freescale.com/support)

### **Europe, Middle East, and Africa:**

Freescale Halbleiter Deutschland GmbH  
Technical Information Center  
Schatzbogen 7  
81829 Muenchen, Germany  
+44 1296 380 456 (English)  
+46 8 52200080 (English)  
+49 89 92103 559 (German)  
+33 1 69 35 48 48 (French)  
[www.freescale.com/support](http://www.freescale.com/support)

### **Japan:**

Freescale Semiconductor Japan Ltd.  
Headquarters  
ARCO Tower 15F  
1-8-1, Shimo-Meguro, Meguro-ku,  
Tokyo 153-0064  
Japan  
0120 191014 or +81 3 5437 9125  
[support.japan@freescale.com](mailto:support.japan@freescale.com)

### **Asia/Pacific:**

Freescale Semiconductor China Ltd.  
Exchange Building 23F  
No. 118 Jianguo Road  
Chaoyang District  
Beijing 100022  
China  
+86 10 5879 8000  
[support.asia@freescale.com](mailto:support.asia@freescale.com)

### **For Literature Requests Only:**

1-800-441-2447 or +1-303-675-2140  
Fax: +1-303-675-2150  
[LDCForFreescaleSemiconductor@hibbertgroup.com](mailto:LDCForFreescaleSemiconductor@hibbertgroup.com)

Information in this document is provided solely to enable system and software implementers to use Freescale Semiconductor products. There are no express or implied copyright licenses granted hereunder to design or fabricate any integrated circuits or integrated circuits based on the information in this document.

Freescale Semiconductor reserves the right to make changes without further notice to any products herein. Freescale Semiconductor makes no warranty, representation or guarantee regarding the suitability of its products for any particular purpose, nor does Freescale Semiconductor assume any liability arising out of the application or use of any product or circuit, and specifically disclaims any and all liability, including without limitation consequential or incidental damages. "Typical" parameters that may be provided in Freescale Semiconductor data sheets and/or specifications can and do vary in different applications and actual performance may vary over time. All operating parameters, including "Typicals", must be validated for each customer application by customer's technical experts. Freescale Semiconductor does not convey any license under its patent rights nor the rights of others. Freescale Semiconductor products are not designed, intended, or authorized for use as components in systems intended for surgical implant into the body, or other applications intended to support or sustain life, or for any other application in which the failure of the Freescale Semiconductor product could create a situation where personal injury or death may occur. Should Buyer purchase or use Freescale Semiconductor products for any such unintended or unauthorized application, Buyer shall indemnify and hold Freescale Semiconductor and its officers, employees, subsidiaries, affiliates, and distributors harmless against all claims, costs, damages, and expenses, and reasonable attorney fees arising out of, directly or indirectly, any claim of personal injury or death associated with such unintended or unauthorized use, even if such claim alleges that Freescale Semiconductor was negligent regarding the design or manufacture of the part.

Freescale™ and the Freescale logo are trademarks of Freescale Semiconductor, Inc. All other product or service names are the property of their respective owners.

© Freescale Semiconductor, Inc. 2010. All rights reserved.

