

Xtrinsic Accelerometers

Xtrinsic MMA16xxKW and MMA26xxKW Airbag Sensors



Overview

Automotive airbag systems continue to enhance passenger safety through the incorporation of increasingly sophisticated features. Automotive suppliers face continuing pressure from the market to improve performance while reducing costs. Both of these trends are expected to continue as the focus on safety remains in the forefront.

Xtrinsic MMA16xxKW and MMA26xxKW inertial satellite sensors are positioned around the car for front and side crash detection. The MMA16xxKW and MMA26xxKW accelerometers are designed to support the DSI communication protocol. Freescale is the only supplier offering both X- and Z-axis over-damped inertial satellite sensors housed in a QFN package, providing a smaller footprint and more flexibility for in-vehicle module orientation.

The MMA16xxKW and MMA26xxKW over-damped MEMS transducer and high-resonance frequency package provide better immunity to overload conditions induced by high magnitude and frequency shocks encountered in airbag satellite applications. The over-damped response of the inertial sensor minimizes signal distortion in the bandwidth of interest when subjected to the high magnitude and high frequency shocks resulting from vehicle collisions.

The Xtrinsic MMA16xxKW and MMA26xxKW sensors are SafeAssure solutions.

Inertial satellite sensors that support the DSI protocol

Airbag System—DSI Protocol

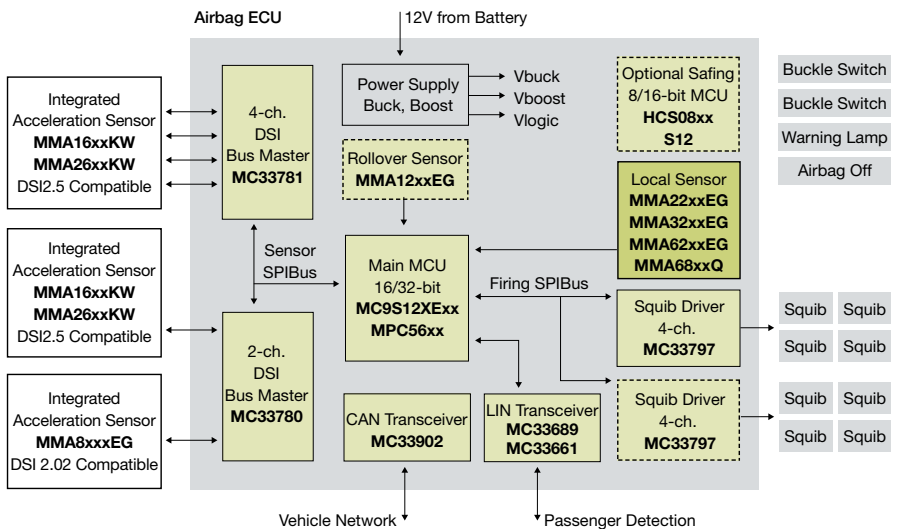

■ Freescale Technology □ Optional



The Xtrinsic MMA16xxKW and MMA26xxKW inertial satellite sensors can be ordered as either X- or Z-axis for module orientation flexibility.



Typical Applications

- Crash detection
- Front crash detection
- Side crash detection
- Rollover sensing

Product Features and Specifications

- $\pm 50g$ to $\pm 312.5g$, nominal full-scale range, X- or Z-axis
- Selectable 180 Hz, two pole, 400 Hz, four pole or 800 Hz, four pole low-pass filter
- DSI 2.5 compliant with full support of mandatory commands
- 16 μs internal sample rate with interpolation to 1 μs
- ($-40\text{ }^{\circ}\text{C}$ to $+125\text{ }^{\circ}\text{C}$) operating temperature range
- QFN 6 x 6 mm 16-pin package
- Qualified AEC-Q100, Revision G, Grade 1 ($-40\text{ }^{\circ}\text{C}$ to $+125\text{ }^{\circ}\text{C}$)

Freescale: The Leader in Automotive Semiconductors

Freescale has offered MEMS-based sensors for over 30 years and is the number one merchant automotive MEMS supplier according to iSuppli. Building on our heritage of sensor innovation, Freescale is proud to announce Xtrinsic sensing solutions that offer the right combination of intelligent integration, logic and customizable software to deliver smarter, more differentiated applications. Freescale sensors, analog products and 8-, 16- and 32-bit MCU families provide intelligence and connectivity for advanced safety, body electronics, chassis, engine control, powertrain, driver information and telematics solutions.

Ordering Information

Contact your Freescale sales representative about the complete product portfolio.

MMA16xxKW and MMA26xxKW Features and Benefits

Features	MMA26xxKWR2	MMA16xxKWR2	Benefits
Axis of sensitivity	X-axis over-damped	Z-axis over-damped	Over-damping achieves a true signal without distortion. The X- or Z-axis provides flexibility for in-vehicle module orientation.
Package	QFN wire frame 6 x 6 x 1.98 mm	QFN wire frame 6 x 6 x 1.98 mm	QFN package provides the smallest footprint for DSI inertial satellite sensors on the market
Package resonance (board mounted)	250 kHz	250 kHz	Robust QFN package provides better immunity to overload conditions
Overload (250g range)	1500g	800g	MEMS transducer provides better immunity to overload conditions induced by high magnitude and frequency shocks encountered in airbag satellite applications
Bus communication Rate	Up to 200 kbaud	Up to 200 kbaud	Increased bandwidth to provide higher data rates, enabling faster sample rates and increased data resolution
System structure	DSI enables up to four sensors on one single bus	DSI enables up to four sensors on one single bus	Automotive suppliers can incorporate more functionality while decreasing the BOM
Strategic partner	Freescale is not a direct competitor to its customers	Freescale is not a direct competitor to its customers	Freescale serves as your strategic partner and supplier, not as a direct competitor

Development tools

Document Number	Description
TWRPI-DSI2.5	The TWRPI-MMA2600 Tower Sensor Pak has a single accelerometer on board that is intended to drive multiple sensors remotely connected through two wires that support the DSI communication protocol.

Documentation

Document Number	Description
MMA16xxKW MMA26xxKW	Product specification data sheets
AN3111	This application note provides recommendations for mounting the QFN package



Look for the latest Tower System addition from Xtrinsic sensing solutions, the TWRPI-DSI2.5. The Tower System modular development platform saves you months of development time through rapid prototyping.

SafeAssure Program: Functional Safety. Simplified.

The Freescale SafeAssure functional safety program is designed to help system manufacturers more easily achieve system compliance with functional safety standards: International Standards Organization (ISO) 26262 and International Electrotechnical Commission (IEC) 61508. The program highlights Freescale solutions—hardware and software—that are optimally designed to support functional safety implementations and come with a rich set of enablement collateral. For more information, visit freescale.com/SafeAssure.

Learn more at freescale.com/automotive

Freescale and the Freescale logo are trademarks of Freescale Semiconductor, Inc., Reg. U.S. Pat. & Tm. Off. SafeAssure, the SafeAssure logo and Xtrinsic are trademarks of Freescale Semiconductor, Inc. All other product or service names are the property of their respective owners. © 2012 Freescale Semiconductor, Inc.

Document Number: MMAx6xxWFS / REV 1

