

Sensors

Overview

Freescale's Global Interactive Blue Chip (GIBC) Attach Program is designed to drive sales of complementary analog, sensor and security products in conjunction with our core microcontroller and embedded processor product families. The idea is simple: When Freescale's "Attach" products

are designed in conjunction with our "Core" products in a system approach, they offer a compelling solution for your customers' end applications.

Freescale offers sensor solutions in the following three areas: acceleration sensors,

electric-field sensing ICs and pressure sensors. Each sensor is compatible with our microprocessor portfolio, offering your customers key building blocks for an intelligent sensor solution.

SENSORS	Attach Device																			
	Accelerometers			Electric-Field			Pressure													
Core Product	MMA1220D	MMA1280D	MMA2280D	MMA6261Q	MMA6270Q	MMA6280Q	MMA7260Q	MMA7261Q	MC33794	MC34940	MC33941	MPXV2010	MPXC2011	MPXM2053	MPXM2102	MPXV7007	MPXV5004	MPXV5050	MPXV6115	MPX2300
8-bit MCU																				
MC68HC908	●	●	●	●	●	●	●	●	●	●	●	●	●	●	●	●	●	●	●	●
16-bit MCU																				
MC9S12	●	●	●	●	●	●	●	●	●	●	●	●	●	●	●	●	●	●	●	●
MC68HC12	●	●	●	●	●	●	●	●	●	●	●	●	●	●	●	●	●	●	●	●
16-bit DSP																				
DSP56F8xx	●	●	●	●	●	●	●	●	●	●	●	●	●	●	●	●	●	●	●	●
DSP5685xx	●	●	●	●	●	●	●	●	●	●	●	●	●	●	●	●	●	●	●	●
32-bit Controllers/ ColdFire®																				
MCF5xxx	●	●	●	●	●	●	●	●	●	●	●	●	●	●	●	●	●	●	●	●
PowerPC™ISA																				
MPC5xx	●	●	●	●	●	●	●	●	●	●	●	●	●	●	●	●	●	●	●	●

In the diagram above, you can see at a glance specific sensor devices that can be designed with our controllers and processors into your customers' solutions. Use this diagram as a tool to help you "attach" relevant sensor devices to our core products.

- This device offers the highest sensitivity for the specific Core product in the left column.
- This device can attach to any of the Core products in the left column.

Benefits

Pressure Sensors

- > Broad portfolio of packaging and porting options for design flexibility
- > Cost-effectiveness
- > Wide operating temperature range of -40°C to 125°C
- > Fully signal conditioned, compensated and calibrated
- > Interface seamlessly with Freescale processors
- > Ratiometric to supply voltage

Acceleration Sensors

- > Broad portfolio, offering 1.5 g to 250 g measurement capability for a wide variety of applications
- > X, XY, XZ, XYZ and Z axis of sensitivity

- > Signal conditioned with internal filter
- > Interface seamlessly with Freescale processors
- > Cost-effectiveness
- > Multi-axis sensing capability on one board design
- > Robust design, high shock survivability
- > Calibrated self-test for functional verification
- > Linear output
- > Ratiometric to supply voltage

Electric-Field Sensing ICs

- > One device simultaneously supports multifunctional applications
- > Low cost
- > Low component count—saves space

Each sensor is compatible with our microprocessor portfolio, providing your customers with the key building blocks for an intelligent sensor solution.

SYSTEM DIAGRAM

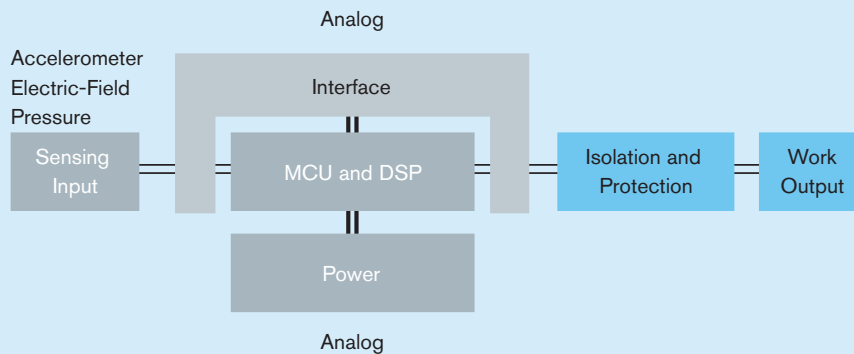

This system diagram is one example of how sensor products can be incorporated into your design. For more information about Freescale's sensor solutions, visit the Web sites listed under the Learn More section below.

Learn More: For more information about Freescale's sensor solutions, visit the following Web sites:

Applications: www.freescale.com/applications

Tools: www.freescale.com/buydirect

Sensor Overview: www.freescale.com/sensors