

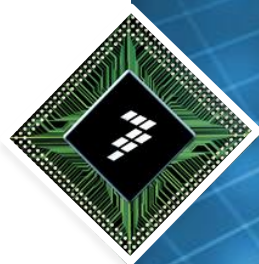

# MC33660 ISO9141 Physical Layer

## Training



MC33660TRN  
Rev 1.0 10/2011

Freescale, the Freescale logo, Altivec, C-5, CodeTEST, CodeWarrior, ColdFire, C-Ware, the Energy Efficient Solutions logo, mobileGT, PowerQUICC, QorIQ, StarCore and Symphony are trademarks of Freescale Semiconductor, Inc., Reg. U.S. Pat. & Tm. Off. BeeKit, BeeStack, ColdFire+, CoreNet, Flexis, Kinetic, MXC, Platform in a Package, Processor Expert, QorIQ Converge, Qorivva, QUICC Engine, SMARTMOS, TurboLink, VortiQa and Xtrinsic are trademarks of Freescale Semiconductor, Inc. All other product or service names are the property of their respective owners. © 2011 Freescale Semiconductor, Inc.



# Agenda

- Introduction
- Internal Block Diagram and Application Schematics
- LIN versus ISO9141



# MC33660

## One Page Overview



Freescale, the Freescale logo, AltiVec, C-5, CodeTEST, CodeWarrior, ColdFire, C-Ware, the Energy Efficient Solutions logo, mobileGT, PowerQUICC, QorIQ, StarCore and Symphony are trademarks of Freescale Semiconductor, Inc., Reg. U.S. Pat. & Tm. Off. BeeKit, BeeStack, ColdFire+, CoreNet, Flexis, Kinetic, MXC, Platform in a Package, Processor Expert, QorIQ Converge, Qoriva, QUICC Engine, SMARTMOS, TurboLink, VortiQa and Xtrinsic are trademarks of Freescale Semiconductor, Inc. All other product or service names are the property of their respective owners. © 2011 Freescale Semiconductor, Inc.

# One Page Overview – ISO9141 Transceiver

## Features

- Operates Over Wide Supply Voltage of 8.0 to 18V
- Operating Temperature of -40 to 125°C
- Interfaces Directly to Standard CMOS Microprocessors
- ISO K Line Pin Protected Against Shorts to Battery
- Thermal Shutdown with Hysteresis
- ISO K Line Pin Capable of High Currents
- ISO K Line Can Be Driven with up to 10 nF of Parasitic Capacitance
- 8.0 kV ESD Protection Capability using passive components.
- Standby Mode: No  $V_{Bat}$  Current Drain with  $V_{DD}$  at 5.0 V
- Low Current Drain During Operation with  $V_{DD}$  at 5.0 V

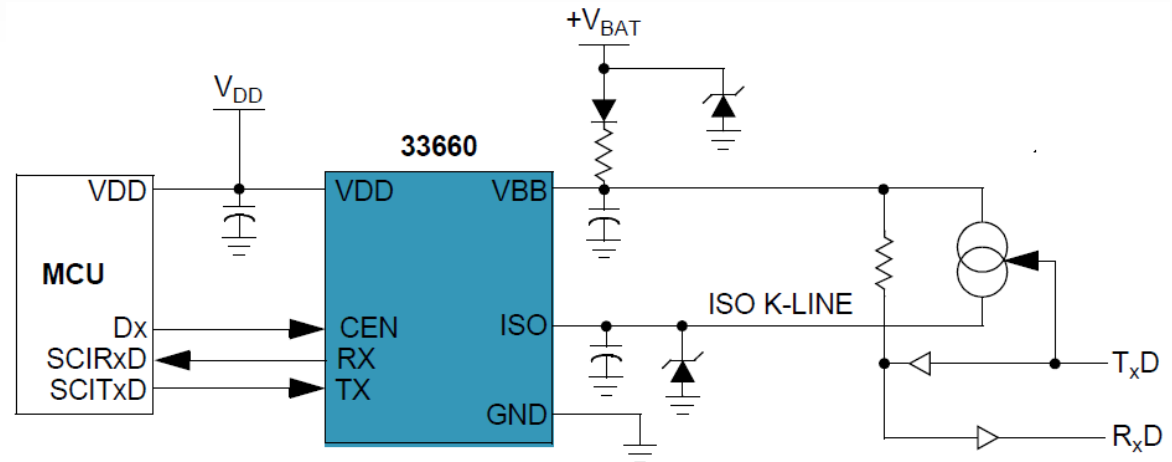

Performance	Typical Values
Bus Outputs	ISO-9141
Data Rate	to 50 kB/s
Operating Voltage	8.0 V - 18 V
Sleep/Stdby Current	50 $\mu$ A
ESD	$\pm$ 2000 V
Operating Temperature	-40°C $\leq$ TA $\leq$ 125°C



D SUFFIX  
EF SUFFIX (PB-FREE)  
98ASB42564B  
8-PIN SOICN



# Internal Block Diagram & Application Schematics



Freescale, the Freescale logo, AltiVec, C-5, CodeTEST, CodeWarrior, ColdFire, C-Ware, the Energy Efficient Solutions logo, mobileGT, PowerQUICC, QorIQ, StarCore and Symphony are trademarks of Freescale Semiconductor, Inc., Reg. U.S. Pat. & Tm. Off. BeeKit, BeeStack, ColdFire+, CoreNet, Flexis, Kinetic, MXC, Platform in a Package, Processor Expert, QorIQ Converge, Qoriva, QUICC Engine, SMARTMOS, TurboLink, VortiQa and Xtrinsic are trademarks of Freescale Semiconductor, Inc. All other product or service names are the property of their respective owners. © 2011 Freescale Semiconductor, Inc.

# Typical Application

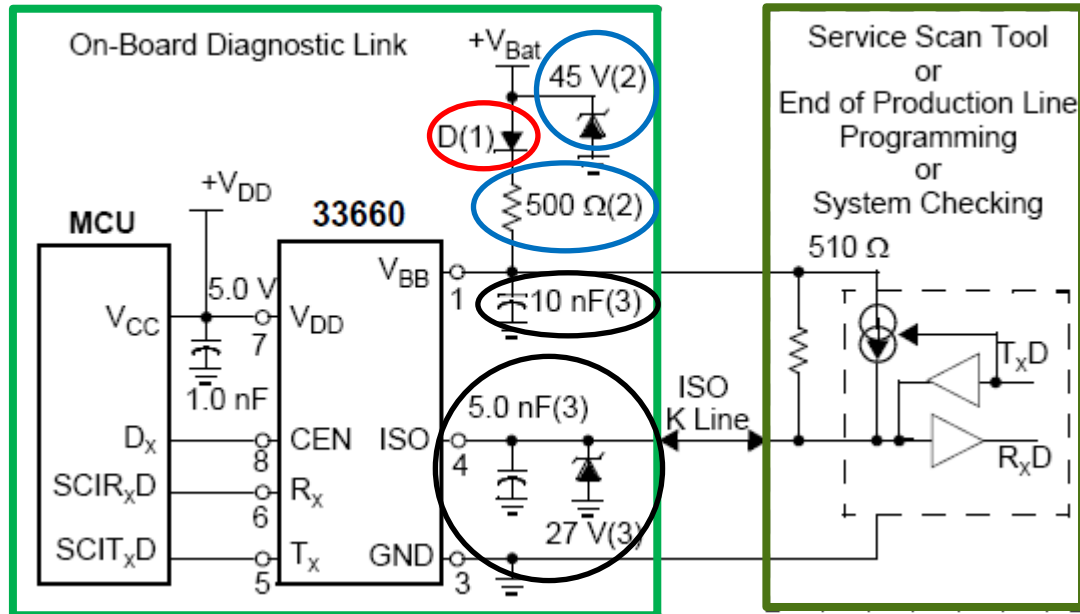

- Reverse Battery (1)
- Overvoltage Transient (2)
- 8.0 kV ESD Protection (3)

# Simplified Application Diagram

## Chip ENABLE

- Controls device Operation Mode
- Normal Mode – 'high'
- Sleep Mode – 'low'
- 5.0V logic compatible

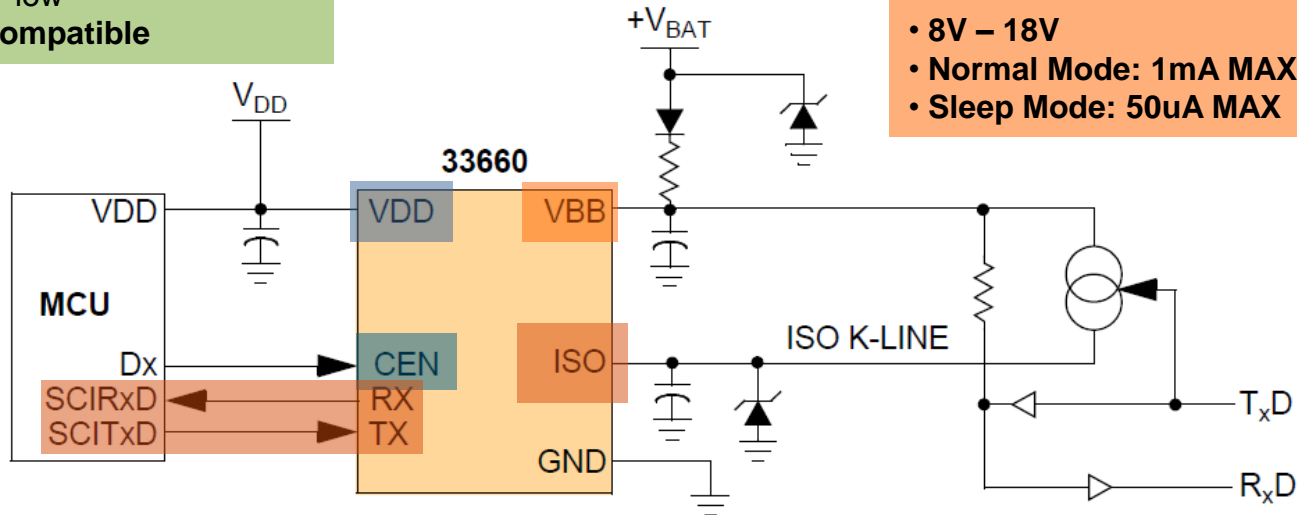

## VBATT

- 8V – 18V
- Normal Mode: 1mA MAX
- Sleep Mode: 50uA MAX

## VDD

- Input determines Logic Level Voltage
- 5.0V Logic Compatible
- Quiescent Operating Current: 1mA MAX
- Sleep State Current: 100uA MAX

## K-Line Transceiver

- ISO9141 Compliant
- Over Temperature Protected
- Short to GND protection

# ISO K-Line Functional Block

## ISO9141 Functional Blocks

1. Transmitter of K-Line
2. Receiver of K-Line
3. K-Line Bus
4. Enable Module
5. VDD Input Module

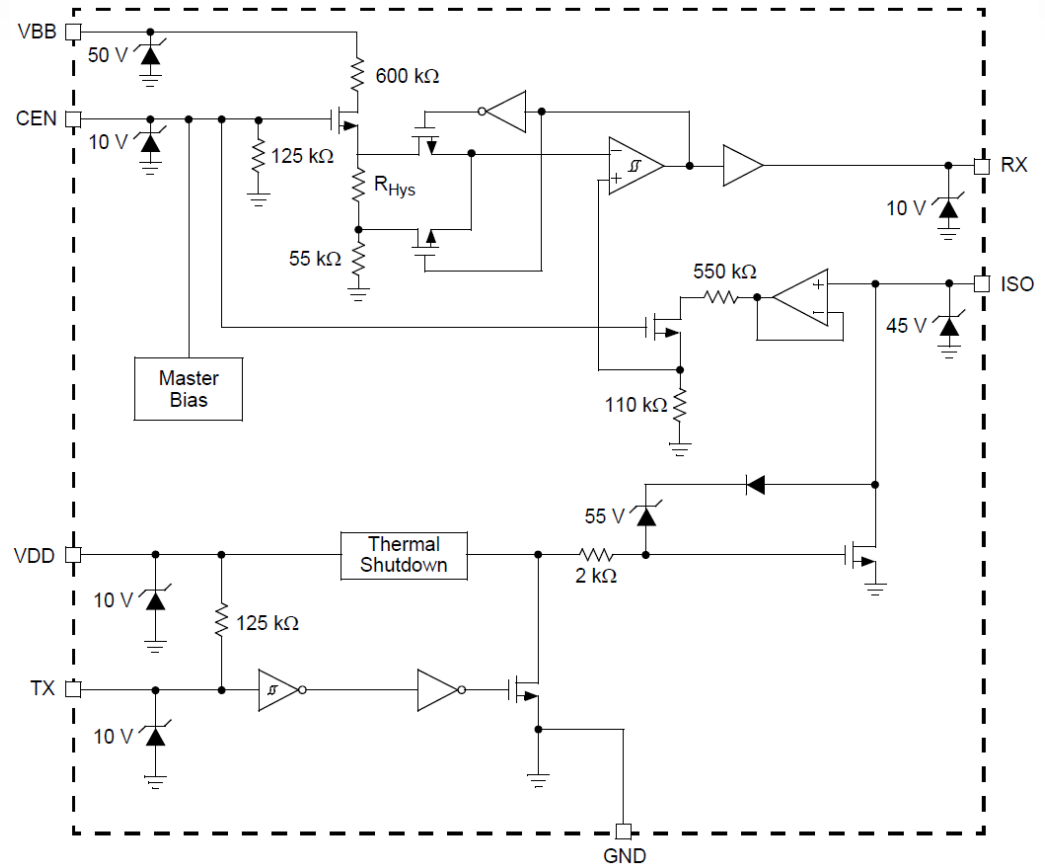



# Transmitter of the K-Line Interface (TXD)

- TXD controls the state of the K-Line
  - Normal Mode
  - TXD High (recessive) = K-Line output High
  - TXD Low (dominant) = K-Line output Low.
- Internal pull-up resistor (125kohm)
  - Forces a recessive state if pin is left open

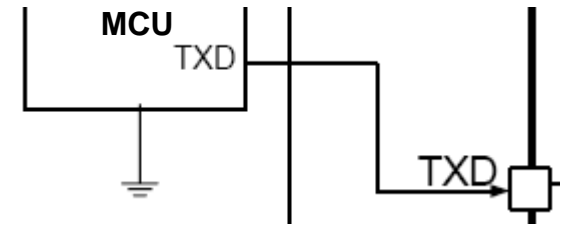

Device Pin:  
TXD (input)

# Receiver of the LIN interface (RXD)

- It reports the state of the LIN to the MCU.
- Its output structure is a tri-state output buffer.
- In Sleep Mode, RXD is high impedance.

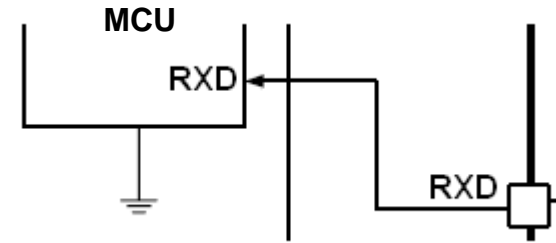

Device Pin:  
RXD (output)

# K-Line Bus Pin (ISO)

The K-Line bus terminal provides a physical layer for single-wire communication in diagnostics automotive applications. The K-Line physical layer is designed to meet the ISO9141 physical layer specification and has the following features:

- 150kbps
- Over-Temperature Shutdown
- Internal pull-up resistor with a TVS
- Active Pull-down
- Short to GND Protection

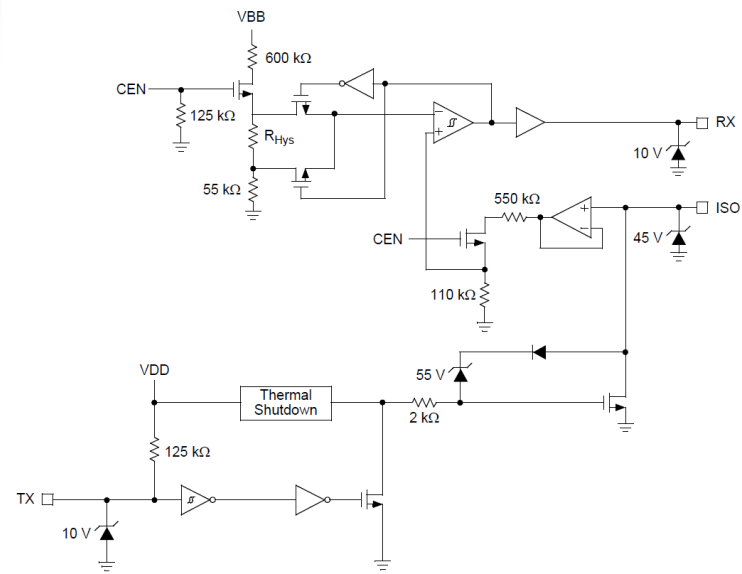

Device Pin:  
ISO (transceiver)

# Enable (CEN)

- It controls the operation of the device
  - Normal Mode: EN = 1
  - Sleep: EN = 0
- 5V logic Thresholds
- Internal pull-down resistor (125kohm)
  - Forces sleep state if pin is left open

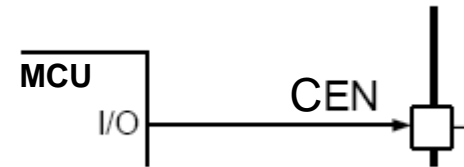

Device Pin:  
CEN (input)



# LIN versus ISO9141



# LIN versus ISO9141

## ISO9141

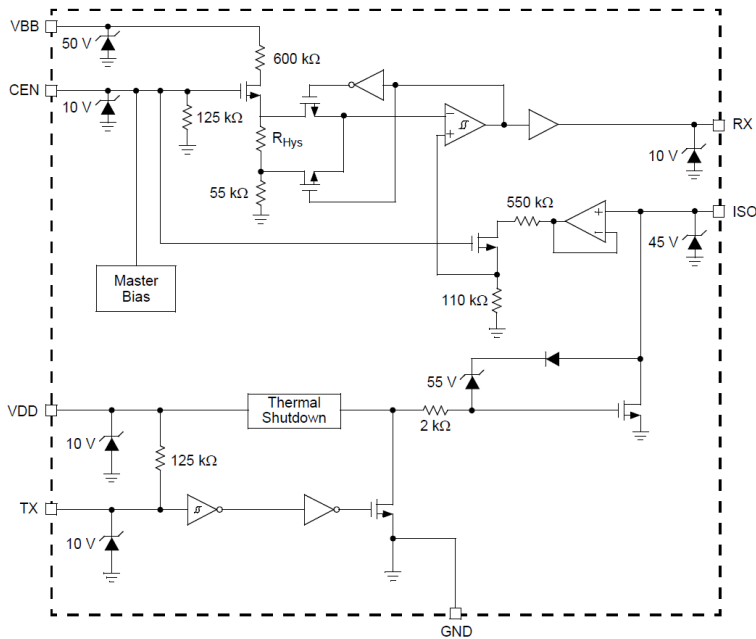

## LIN

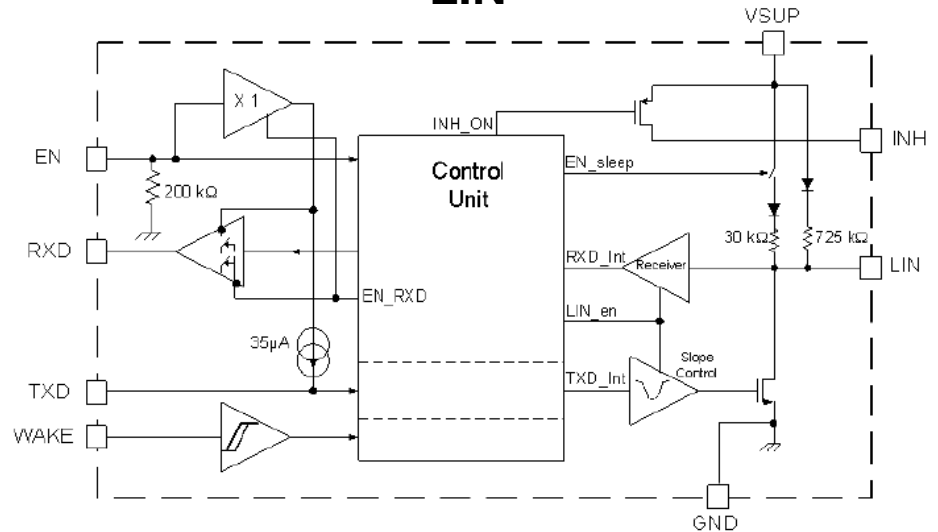

**Simplified Internal Block Diagram**

# ISO9141

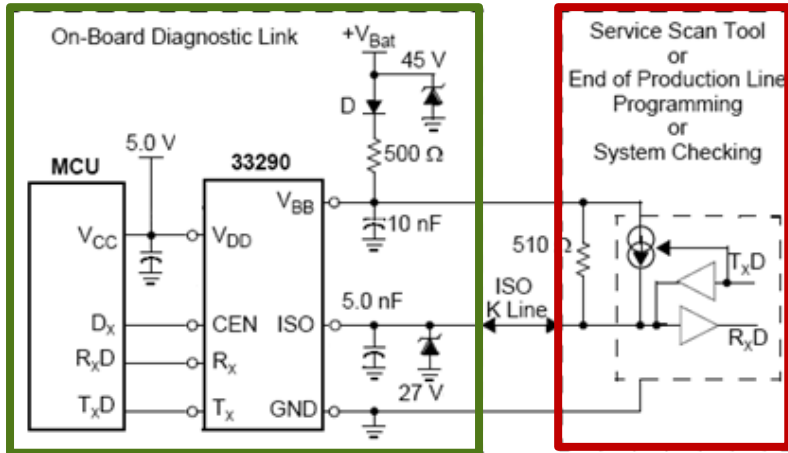

# LIN

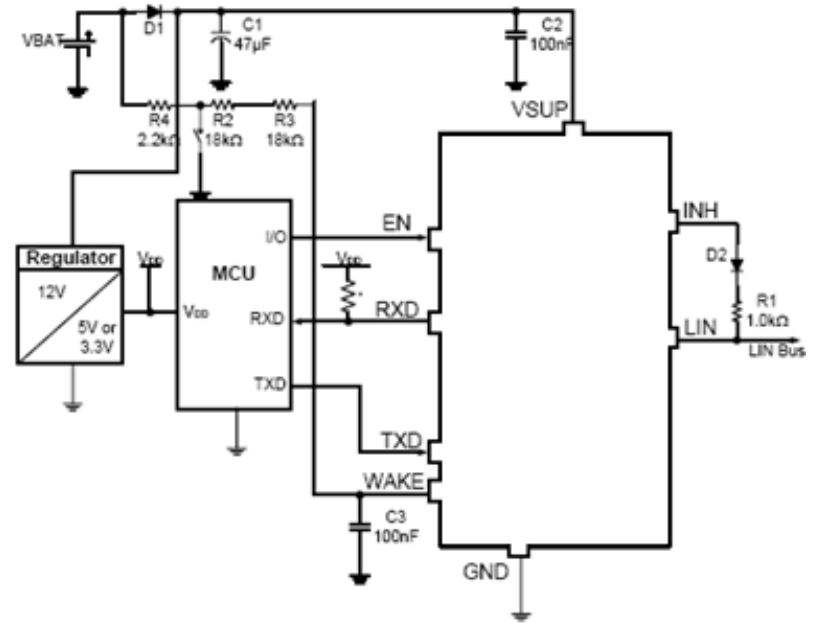

Simplified Application Schematics

# ISO9141 versus LIN 2.1 – comparison table

K-Line Test Parameter values							
Parameter	ISO9141			LIN2.1			Comments
	Parameter value Min	Parameter value Max	Unit	Parameter value Min	Parameter value Max	Unit	
Operating temperature	0	50	°C	-40	125	°C	
Operating voltage	8	18	V	7	18	V	
Voltage high receive threshold	0.7xVb	Vb	V	0.6xVb		V	Receiver Recessive State
Voltage high transmit scan tool threshold	0.9xVb		V				
Voltage high transmit vehicle threshold	0.8xVb		V				
Voltage low receive treshold		0.3xVb	V				
Voltage low transmit vehicle threshold	0	0.2xVb	V				Not Specified in the LIN2.1 but the silicon shows a low level around 2V - Not compliant
Voltage low transmit scan tool threshold		0.1xVb	V				
Bit rate	4975	5025	bit/s	0	100	kb/s	Up to 10kp/s or up to 20kb/s or up to 100kb/s
Bus idle time	2	infini	ms				
Synchronisation delay	60	300	ms				
Keyword 1 delay	5	20	ms				
Keyword 2 delay	0	20	ms				
Inter-byte delay	25	50	ms				
Bus idle time (address retransmitting)	300	infini	ms				
Tester bus line capacitance	0	2	nF	1	10	nF	Total capacitance of the bus including slave and master capacitance
Tester bus line resistance to Vb	485	515	ohms		1	kohm	ISO9141 Test Tool specified Pull-Up resistance is ~510ohms and LIN Master Pull-Up resistance is ~1Kohm, BUT this is highly dependant on the number of LIN nodes (a LIN network can have a MIN Pull-Up resistance down to ~500ohms with MAX number of LIN nodes).
Rise time	0	0.1/BitRate	µs				ISO9141 prop delay from TxD to BUS Dominant and Recessive is <2us. This is achievable by our LIN block when in Fast Mode. Tested this on the bench at all temperatures and with worst case loading conditions (500ohm, 10nF)
Fall time	0	0.1/BitRate	µs				
Tester bit rate	10348	10452	bit/s	0	100	kb/s	up to 10kp/s or up to 20kb/s or up to 100kb/s
Vehicle bus line capacitance	0	7.2	nF	1	10	nF	Total capacitance of the bus including slave and master capacitance
Vehicle bus line resistance to Vb	10		kohm				Can be adjusted externally. The ISO Diagnostics Test Tool (Master Node) is the main factor in the network's overall load, which is terminated with a 510Ω pull-up resistor.
Vehicle bus line resistance to Ground	5		kohm				
Baud rate	10223	10577	bit/s	0	100	kb/s	up to 10kp/s or up to 20kb/s or up to 100kb/s
Fully compatible							
Compatible with adjustments							
Not compliant							

**Conclusion:** As Described on the previous table, Freescale's LIN transceiver circuit block is not compliant to the ISO9141 Specification. It can be used in ISO Networks with some loading adjustments. It's possible that the number of ISO nodes will be limited if LIN nodes are implemented on the same network. The ISO Diagnostics Test Tool (Master Node) is the main factor in the network's overall load, which is terminated with a 510Ω pull-up resistor. But if LIN slave nodes are added to the BUS, the network resistance will still be decreased. The main issue to be compliant is the low voltage level during transmission.



