



Analog, Mixed-Signal and Power Management

## MC34933

### 1.4 A Dual H-Bridge Driver Compatible with 3 V Logic

#### Target Applications

- Bipolar stepper motors/brushed DC motors
- SLR lens shutter control
- Optical disc drive
- Other portable electronics

#### Overview

The MC34933 is a monolithic dual H-bridge power IC ideal for portable electronic applications containing bipolar stepper motors and/or brush DC motors such as cameras and disk drive head positioning. The MC34933 operates from 2 V to 7 V using the internal charge pump with independent control of each H-bridge via parallel MCU interface. The device features built-in shoot-through current protection and an undervoltage shutdown function. The MC34933 has four operating modes for each channel: forward, reverse, brake and tristated (high impedance). The MC34933 has a low total  $R_{DS(on)}$  of 1.0  $\Omega$  (Max) @  $T_A = 25^\circ\text{C}$ .

The MC34933 efficiently drives many types of micro motors with low power dissipation owing to its low-output resistance and high-output slew rates. The H-bridge outputs are controlled with pulse width modulation (PWM) signals independently up to 200 kHz for speed/torque and current control.

#### Simplified Application Drawing

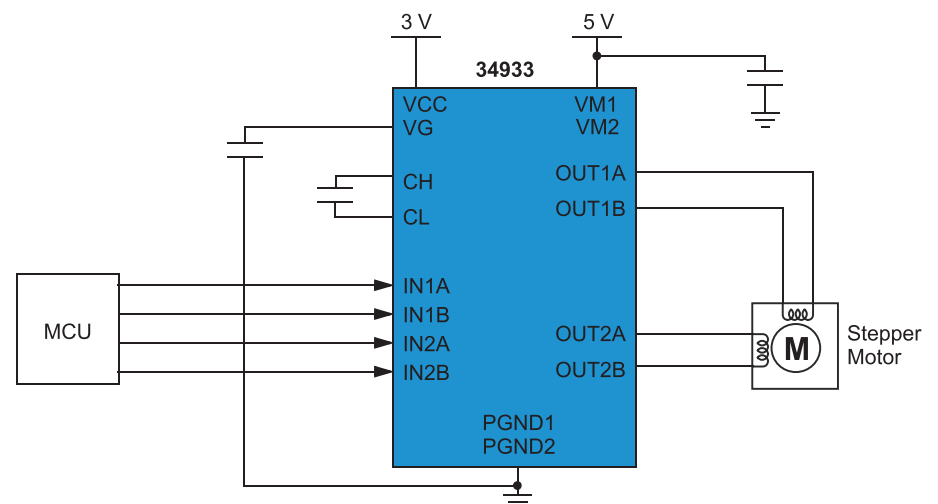

## Freescal: A Leader in Analog Solutions

Expanding on more than 30 years of innovation, Freescale is a leading provider of high-performance products that use SMARTMOS technology combining digital, power and standard analog functions. Freescale supplies analog and power management ICs that are advancing the automotive, consumer, industrial and networking markets. Analog solutions interface with real-world signals to control and drive for complete embedded systems.



16-PIN UQFN  
98ASA00110D

## Product Features and Benefits

Features	Function	Benefits
Dual H-bridges	Parallel or independent operation	Easy MCU interfacing to dual H-bridges
Low total $R_{DS(on)}$	1.0 $\Omega$ Typ	Reduces conduction power loss in the switch, improving efficiency with which power is transferred to load
Output current	400 mA continuous	Low $R_{DS(on)}$ bridge maximizes current to a load
Shoot-through current protection circuit	Ensures that each pair of switches connected to power and ground are never fully on at the same time	Avoids direct current from power rail through switches to ground
Pulse width modulation	Control input frequency up to 200 kHz	Precise, high-frequency control over switch
Low power consumption	Low quiescent current	Long battery life for portable applications
Undervoltage detection and shutdown circuit	If the supply voltage drops below a certain threshold, the output power stage switches to a tri-state condition	Prevent erratic circuit operation
Pb-free UQFN package	EP suffix	Environmentally preferred, low-profile package for portable designs

## Performance

Performance	Typical values
Number of channels	2
Maximum load output current, $T_A = 25\text{ }^\circ\text{C}$	1.0 A
H-bridge operating voltage	2 to 7 V
Logic operating voltage	2.7 to 5.5 V
Input PWM max	200 kHz

## Documentation

Freescal Document Number	Title	Description
MC34933	Dual H-Bridge Driver with Charge Pump	Data sheet
SG1002	Analog Product Selector Guide	Selector guide

For more information, please visit [freescale.com/analog](http://freescale.com/analog)

Freescal and the Freescal logo are trademarks of Freescal Semiconductor, Inc., Reg. U.S. Pat. & Tm. Off. SMARTMOS is a trademark of Freescal Semiconductor, Inc. All other product or service names are the property of their respective owners. © 2014 Freescal Semiconductor, Inc.

Document Number: MC34933FS REV 2

