



**PACKING LIST - KIT CONTENTS**

**KIT17C724EPEVBE**  
**0.4A Dual H-Bridge Motor Driver**

<u>QUANTITY</u>		<u>REVISION</u>
<b>1</b>	<b>CD - ROM</b>	<b>1.0</b>
	Documentation Package for KIT17C724EPEVBE	
	Notice	----
	Instructions	1.0
	EVB setup diagram	1.0
	Assembly Drawing	1.0
	PCB - Top copper	1.0
	Bill of Material	1.0
	MPC17C724 Data Sheet	2.0
	MPC17C724 Fact Sheet	1.0
	APDPAK/D Analog Portfolio Package	----
	Freescale Analog Web Page Link	
<b>1</b>	<b>17C724 EVALUATION BOARD</b>	
<b>1</b>	<b>WARRANTY CARD, FREESCALE, 920-75133</b>	
<b>1</b>	<b>BR1530 Technical Information Center Document, 920-90570-00</b>	

ARCHIVE

## IMPORTANT NOTICE

**Freescale provides the enclosed product(s) under the following conditions:**

**This evaluation kit is intended for use of ENGINEERING DEVELOPMENT OR EVALUATION PURPOSES ONLY.** It is provided as a sample IC pre-soldered to a printed circuit board to make it easier to access inputs, outputs, and supply terminals. This EVB may be used with any development system or other source of I/O signals by simply connecting it to the host MCU or computer board via off-the-shelf cables. This EVB is not a Reference Design and is not intended to represent a final design recommendation for any particular application. Final device in an application will be heavily dependent on proper printed circuit board layout and heat sinking design as well as attention to supply filtering, transient suppression, and I/O signal quality.

The goods provided may not be complete in terms of required design, marketing, and or manufacturing related protective considerations, including product safety measures typically found in the end product incorporating the goods. Due to the open construction of the product, it is the user's responsibility to take any and all appropriate precautions with regard to electrostatic discharge. In order to minimize risks associated with the customers applications, adequate design and operating safeguards must be provided by the customer to minimize inherent or procedural hazards. For any safety concerns, contact Freescale sales and technical support services.

As a prototype, this product does not fall within the scope of the European Union directive on electromagnetic compatibility and therefore may not meet the technical requirements of the directive. Please be aware that the products received may not be regulatory compliant or agency certified (FCC, UL, CE, etc.).

Should this evaluation kit not meet the specifications indicated in the kit, it may be returned within 30 days from the date of delivery and will be replaced by a new kit.

Freescale reserves the right to make changes without further notice to any products herein. Freescale makes no warranty, representation or guarantee regarding the suitability of its products for any particular purpose, nor does Freescale assume any liability arising out of the application or use of any product or circuit, and specifically disclaims any and all liability, including without limitation consequential or incidental damages. "Typical" parameters can and do vary in different applications and actual performance may vary over time. All operating parameters, including "Typical", must be validated for each customer application by customer's technical experts.

Freescale does not convey any license under its patent rights nor the rights of others. Freescale products are not designed, intended, or authorized for use as components in systems intended for surgical implant into the body, or other applications intended to support or sustain life, or for any other application in which the failure of the Freescale product could create a situation where personal injury or death may occur.

Should Buyer purchase or use Freescale products for any such unintended or unauthorized application, Buyer shall indemnify and hold Freescale and its officers, employees, subsidiaries, affiliates, and distributors harmless against all claims, costs, damages, and expenses, and reasonable attorney fees arising out of, directly or indirectly, any claim of personal injury or death associated with such unintended or unauthorized use, even if such claim alleges that Freescale was negligent regarding the design or manufacture of the part.

Freescale™ and the Freescale logo are trademarks of Freescale Semiconductor, Inc. All other product or service names are the property of their respective owners. © Freescale Semiconductor, Inc. 2006

## INSTRUCTIONS

### **KIT17C724EPEVBE** **0.4A Dual H-Bridge Motor Driver**

---

#### Using the EVB

**Warning: Always wear Safety Glasses when working around electronic modules and when soldering.**

1. MPC17C724 Evaluation board allows the customer to quickly evaluate features of the device with a simple bench top setup. Review datasheet applications area for configurations.

Notes : Although VM1 and VM2 are connected internally, they must be connected externally to attain sufficient power distribution.

REVISIONS			
REV	DESCRIPTION	DATE	APPROVED
1.0	ORIGINAL	2/2/2006	

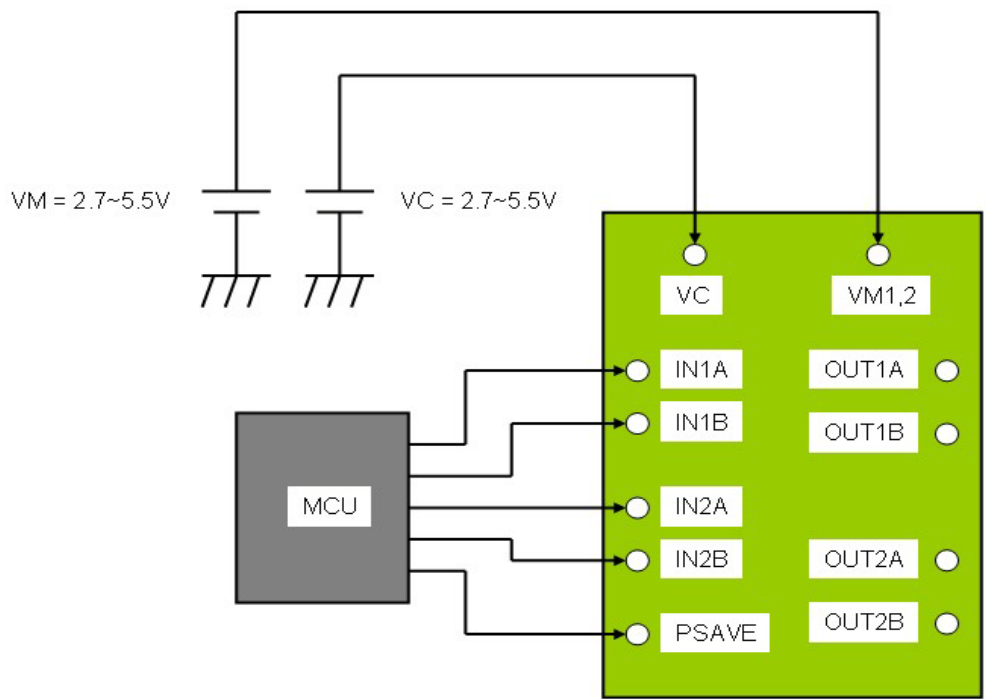



REVISIONS			
REV	DESCRIPTION	DATE	APPROVED
1.0	ORIGINAL	2/2/2006	---

NOTES:  
1. TOP COPPER

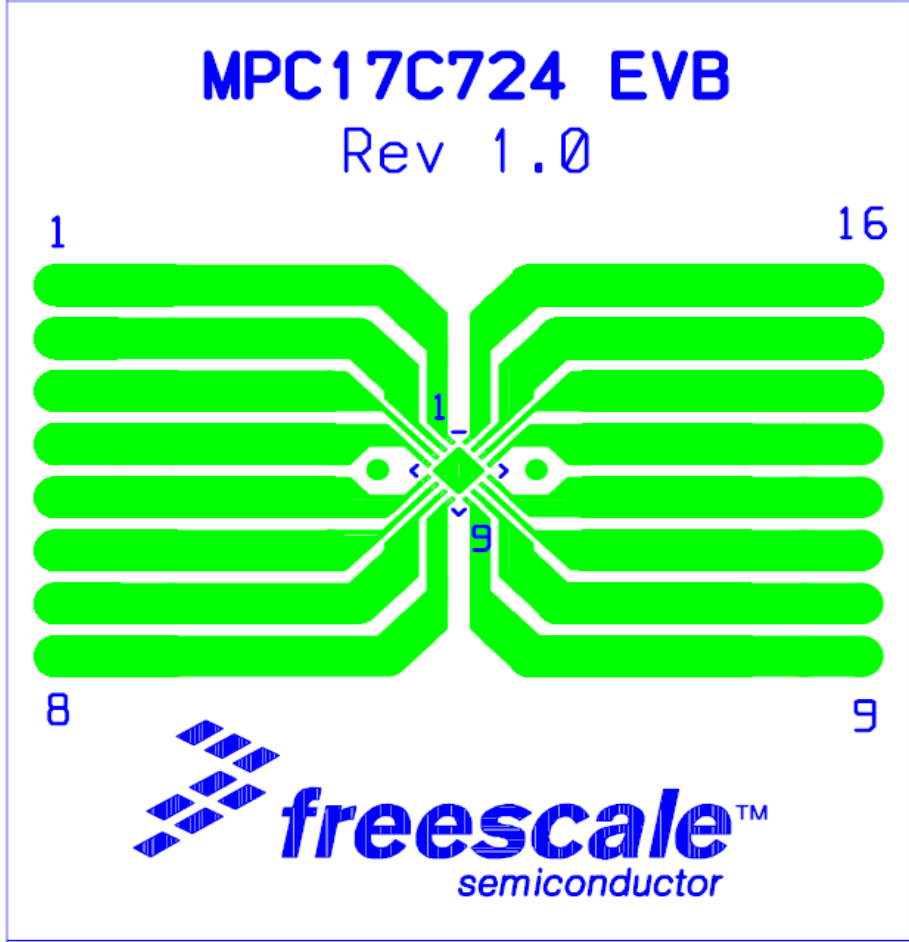

THIS DOCUMENT CONTAINS INFORMATION PROPRIETARY TO FREESCALE SEMICONDUCTOR AND SHALL NOT BE USED FOR ENGINEERING DESIGN, PROCUREMENT OR MANUFACTURE IN WHOLE OR IN PART WITHOUT CONSENT OF FREESCALE SEMICONDUCTOR.

TITLE  
**PWB17C724EPEVBE  
TOP COPPER**

REV  
1.0

