

MC33291L

Eight Output Switch with SPI Interface (1.2 Ω R_{DS(ON)})

Power
Actuation

Low-Side
Switch

DESCRIPTION

The 33291L is a versatile low-side smart switch incorporating an 8-bit serial shift register to control the 8-bit parallel output latch to provide control of the eight independent output power (ON/OFF) switches. These devices are very useful to drive solenoids, relays, lamps, DC-motors, and other moderate current load (0.5 A) applications.

The 33291L interfaces directly with microcontrollers to control various inductive or incandescent loads. The circuit's innovative monitoring and protection features include very low standby current, SPI cascadable fault reporting, internal 53 V clamp on each output, output specific diagnostics, and independent shutdown of outputs.

33291L SIMPLIFIED APPLICATION DIAGRAM

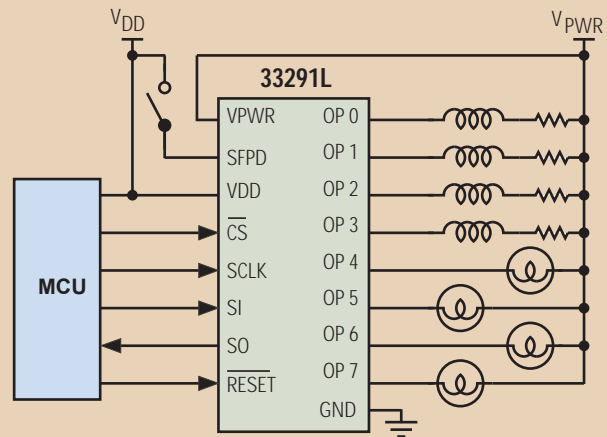

ARCHIVE INFORMATION

ARCHIVE INFORMATION

APPLICATIONS

- Automotive Systems
- Aircraft Systems
- Robotics
- Farm Equipment
- Industrial Actuator Controls
- Small DC-Motor Controls
- Marine Systems
- Incandescent Lamp Control
- Applications where low-side switch control with diagnostics is necessary

PERFORMANCE

TYPICAL VALUES

Outputs	8
R _{DS(ON)} @ 25°C	1.2 Ω
Operating Voltage	5.5 – 26.5 V
Peak Current	1.0 A each output
Control	SPI
Operating Temperature	-40°C ≤ T _A ≤ 125°C
Junction Operating Temperature	-40°C ≤ T _J ≤ 150°C

FEATURES

- Designed to Operate Over Wide Supply Voltages of 5.5 V to 26.5 V
- Interfaces to Microprocessor Using 8-Bit SPI I/O Protocol up to 3.0 MHz
- 1.0 A Peak Current Outputs with Maximum $R_{DS(ON)}$ of 1.6 Ω at $T_J - 150^\circ\text{C}$
- Outputs Current-Limited to Accommodate In-Rush Currents Associated with Switching Incandescent Loads
- Output Voltages Clamped to 53 V During Inductive Switching
- Maximum Sleep Current (I_{PWR}) of 25 μA
- Maximum of 4.0 mA I_{DD} During Operation
- Devices available for comparison are in the Analog Product Selector Guide - SG1002, and Automotive Product Selector Guide - SG187.

PROTECTION	DETECT	LIMITING	SHUT DOWN	AUTO RETRY	STATUS REPORTING
Overvoltage	●		●		●
Overcurrent/SC	●	●	●	●	●
Overtemperature	●		●	●	
Open Load	●				●

CUSTOMER BENEFITS

- Low system cost, minimal component count, simplified circuitry, and minimal boardspace
- Simplified system design with direct interfacing to microprocessor
- Simplified inductive load driving due to internally clamped outputs
- Capable of switching capacitive, incandescent, or inductive loads
- Versatile outputs capable of parallel operation accommodating increased output load current combinations or for the reduction of $R_{DS(ON)}$
- Capable of Pulse width Modulating loads

QUESTIONS

- Do you need to reduce system complexity for switching multiple loads using a microcontroller?
- Do you have very little PC board space available for load control?
- Do you require multiple high-efficiency switches to control capacitive, incandescent, or inductive loads over a wide temperature range?
- Are you looking for an easy-to-design-in solid state switch, capable of switching eight different loads?
- Do you need a "smart" switch with programmable internal protection features as well as fault reporting?
- Do you need multiple switches that can be controlled from a microcontroller via SPI protocol?

ORDERING INFORMATION

Device	Temperature Range (T_A)	Package
MC33291LDW/R2	-40°C to 125°C	24 SOICW
MCZ33291LEG/R2		24 SOICW (Pb-free)

Data Sheet Order Number MC33291L

Contact Sales for Evaluation Kit Availability

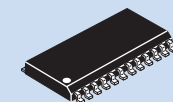

24 SOICW
1.27 mm Pitch
15.4 mm x 7.5 mm Body