

MC33996

16-output switch with SPI control

Target Applications

- Aircraft systems
- Automotive systems
- Marine applications
- Robotic systems
- Farm equipment
- Actuator control
- Small DC motor control
- LED and incandescent lamp control
- Other applications where low-side switch control is required

Overview

The 33996 is a 16-output low-side switch with a 24-bit serial input control. It is designed for a variety of applications including inductive, incandescent and LED loads. The serial peripheral interface (SPI) provides both input control and diagnostic readout. A pulse width modulation (PWM) control input is provided for pulse width modulation of multiple outputs at the same duty cycle. A dedicated reset input provides the ability to clear all internal registers and turn all outputs off.

The 33996 directly interfaces with MCUs and is compatible with both 3.3 V and 5.0 V CMOS logic levels. The 33996, in effect, serves as a bus expander and buffer with fault management features that reduce the MCU's fault management burden.

MC33996 Simplified Application Diagram

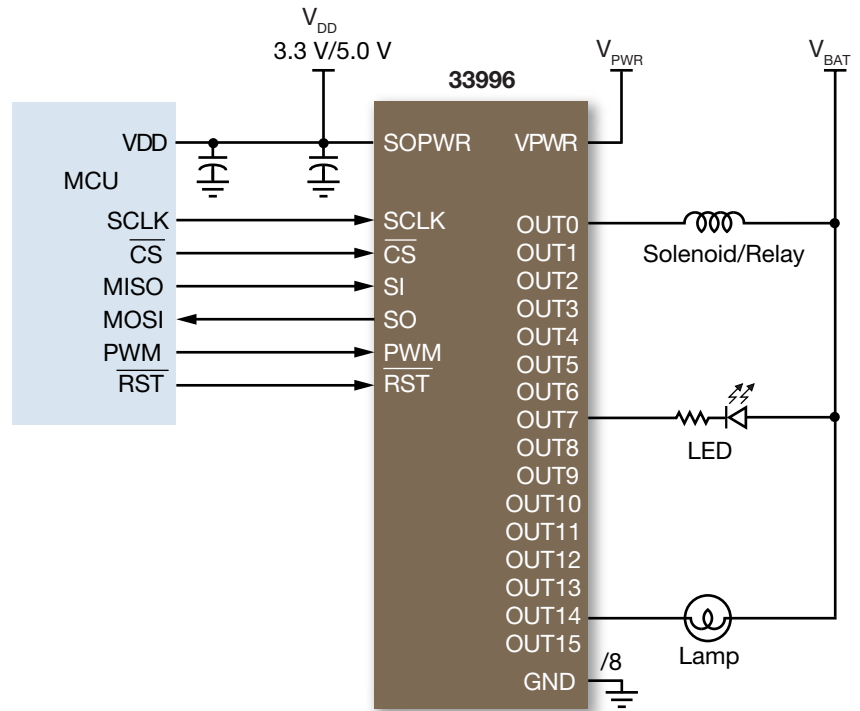

Performance

Performance	Typical Values
Outputs	16
RDS _{ON} @ 25°C	0.55 Ω
Operating Voltage, V _{PWR}	5.0 V–27 V
Operating Voltage, SO _{PWR}	3.3 V–5.0 V
Current Limit	1.2 A Each Output
Control	SPI with PWM
Operating Temperature	-40°C ≤ T _A ≤ +125°C
Junction Operating Temperature	-40°C ≤ T _J ≤ +150°C

Features

- Designed to operate $5.0\text{ V} < V_{\text{PWR}} < 27\text{ V}$
- 24-bit SPI for control and fault reporting, 3.3 V/5.0 V compatible
- Outputs are current limited (0.9 A to 2.5 A) to drive incandescent lamps
- Output voltage clamp of +50 V during inductive switching
- ON/OFF control of open load detect current (LED application)
- V_{PWR} standby current $< 10\ \mu\text{A}$
- $R_{\text{DS(ON)}}$ of $0.55\ \Omega$ at 25°C typical
- Independent overtemperature protection
- Output selectable for PWM control
- Output ON short-to- V_{BAT} and OFF short-to-ground /open detection
- 32-pin exposed pad package for thermal performance
- Pb-free packaging designated by suffix code EK

Customer Benefits

- Control of up to 16 loads using a single IC and few external components
- Simple to hook up
- Can directly interface with either 3.3 or 5.0 V microcontrollers using SPI
- Reduced PC board space resulting in enhanced application reliability and lower costs
- Outputs controlled via SPI and able to be pulse width modulated
- Diagnostic capability making for easy system troubleshooting

Questions

- Need to reduce the complexity of controlling multiple loads?
- Need a single IC that can switch up to 16 incandescent lamp or inductive loads?
- Do you require a "smart" switch with internal protection features and fault diagnostic reporting?
- Do some or all of your multiple loads need PWM control?
- Do you need an IC that supports 3.3 and 5.0 V microcontrollers?

Protection

Protection	Detect	Limiting	Shut Down	Auto Retry	Status Reporting
Overvoltage	•		•	•	•
Undervoltage	•		•		
Overcurrent/SC	•	•	•	•	•
Overtemperature	•		•	•	•
Open Load	•			•	•

Ordering Information

Device	Temperature Range (T_A)	Package
MCZ33996EK/R2	-40°C to $+125^\circ\text{C}$	32 SOICW-EP (Pb-free)
MCZ33996—Data Sheet Order Number		
SG1002—Analog Product Selector Guide		
SG187—Automotive Product Selector Guide		
Contact Sales for Evaluation Kit Availability		

32 SOICW-EP



0.65 mm Pitch
11.0 mm x 7.5 mm Body
5.7 mm x 4.6 mm Exposed Pad

Learn More:

For current information about Freescale products and documentation, please visit www.freescale.com.