

# MC33984

## Dual Intelligent High-current Self-protected Silicon High Side Switch (4.0 mOhm)

### Applications

- Aircraft and marine systems
- Automotive and robotic systems
- Farm equipment
- Industrial actuator controls
- Lamp and inductive load controls
- DC motor control applications requiring diagnostics
- Applications where high side switch control is required

### Overview

The MC33984 is a dual self-protected 4.0 mΩ silicon switch used to replace electromechanical relays, fuses, and discrete devices in power management applications. The MC33984 is designed for harsh environments, and it includes self-recovery features. The device is suitable for loads with high inrush current, as well as motors and all types of resistive and inductive loads.

Programming, control and diagnostics are implemented via the serial peripheral interface (SPI). A dedicated parallel input is available for alternate and pulse-width modulation (PWM) control of each output. SPI-programmable fault trip thresholds allow the device to be adjusted for optimal performance in the application.

The MC33984 is packaged in a power-enhanced 12 x 12 mm nonleaded PQFN package with exposed tabs.

MC33984 Simplified Application Drawing

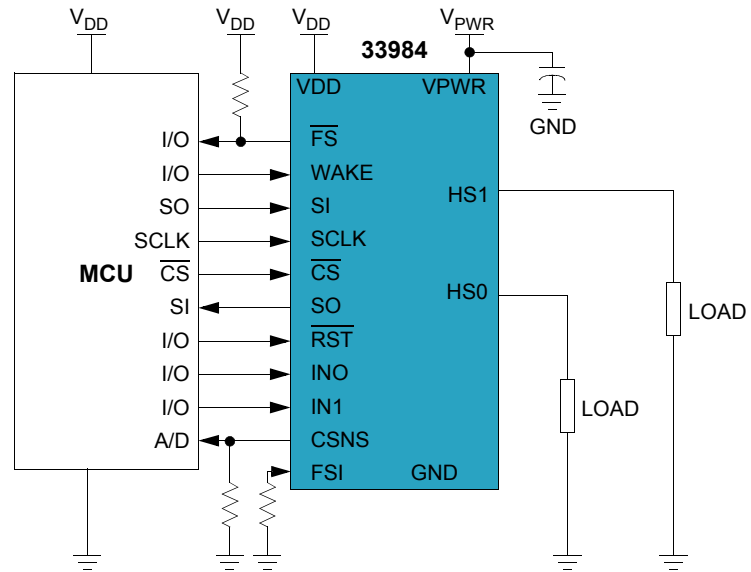

Performance	Typical Values
Outputs	2
$R_{DS(ON)}$ at 25 °C	3.5 mΩ
Operating Voltage	6.0 - 27 V
Peak Current	100 A
PWM Input Control	150 Hz / 1.0 kHz
ESD	± 2000 V
Ambient Operating Temperature	-40 °C ≤ T <sub>A</sub> ≤ 125 °C
Junction Operating Temperature	-40 °C ≤ T <sub>J</sub> ≤ 150 °C

## Features

- Dual 4.0 mΩ max high side switch with parallel input or SPI control
- 6.0 to 27 V operating voltage with standby currents < 5.0 μA
- Output current monitoring with two SPI-selectable current ratios
- SPI control of over-current limit, over-current fault blanking time, output OFF open load detection, output ON/OFF control, watchdog timeout, slew rates, and fault status reporting
- SPI status reporting of over-current, open and shorted loads, over-temperature, under-voltage and over-voltage shutdown, fail-safe pin status, and program status
- Enhanced -16 V reverse polarity V<sub>PWR</sub> protection

## Benefits

- Offers an economical high-current switch requiring few external parts and is simple to hook up
- Can be used with micro processors having SPI in high side switching applications
- High efficiency, low ON resistance switching
- Reduced PC board space resulting in enhanced application reliability and lower costs
- Numerous internal protection and programmable performance features
- Output internally clamped to -17 V for inductive load switching applications
- Two integrated high-power switches in the same solution

## Questions

- Need a dual high side switch capable of switching 100 A per output?
- Need a micro controller controlled high side switch with a programmable watchdog to monitor the MCU?
- Do you have limited PC board space available for load control?
- Need an easy-to-design high side switch with internal charge pump capable of low-speed PWM switching with a dedicated parallel input?

## Protection

Protection	Detect	Shut Down	Auto Retry	Status Reporting
Over-voltage	•	•	•	•
Under-voltage	•	•		•
Over-current / SC	•	•		•
Open Load	•			•
Output Current	•			•
Over-temperature	•	•	•	•
Short-to-Ground	•	•		•

## Ordering Information

Device (for Tape and Reel, add an R2 suffix)	Temperature range (T <sub>A</sub> )	Package
MC33984CHF4	-40 ≤ T <sub>A</sub> ≤ 125 °C	16 PQFN

## Development Tools

Part Number	Description
KIT33984CEVBE	Evaluation Kit - 33984, Dual 4 mΩ Intelligent High-current Self-protected Silicon High Side Switch

## Documentation

Document Number	Title	Description
MC33984	Data Sheet	Dual intelligent high-current self-protected silicon high side switch (4.0 mΩ)
SG1002	Selector Guide	Analog Product Selector Guide
SG187	Selector Guide	Automotive Product Selector Guide
AN2467	Application Note	Power Quad Flat No-lead Package
AN3274	Application Note	eXtreme Switch Protection Guidelines

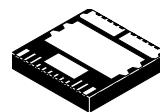

(Bottom View)  
16 PQFN  
98ARL10521D

**Learn More:** For current information about Freescale products, please visit [www.freescale.com](http://www.freescale.com).